



Cembre



Certified Quality Management System



Certified Environmental Management System



Certified Occupational Health & Safety Management System

1969 2019

50 years of electrical connections

GENERAL CATALOGUE



QUALITY POLICY AND OBJECTIVES



This catalogue illustrates the range of our standard products. For each product family we indicate the principal features, and sometimes the most frequent applications and the necessary guidelines for a correct application. Our sales personnel are at your disposal to supply more detailed information and our design and development engineers are available to study new solutions to particular applications.

On 14th December 1990 Cembre SpA Quality Management System was certified by Lloyd's Register of Quality Assurance (LRQA) according to ISO 9002-1987 EN 29002 - 1987 BS 5750: Part 2: 1987 for the manufacture of insulated and uninsulated copper crimping connectors.

Then on 22nd December 1992 Cembre SpA was certified ISO 9001 for the design and manufacture of cable accessories, electrical connectors and associated tools. The activities of the main premises in Brescia, the Italian regional offices and the subsidiary companies in Great Britain, France, Spain, Germany and USA are governed by a single Quality System, assessed by Lloyd's Register of Quality as conforming to the ISO 9001:2015 norm, for the design, manufacture and sales of electrical connectors and associated tools, cable accessories, marking systems, toolings and products for railway applications. Tools for pressed joints for water, gas, steam, waste and HVAC and related accessories. In house repair, refurbishment and calibration of toolings.

This guarantees a homogeneous and high quality level of the products and services that Cembre offers to its customers.

Cembre S.p.A. has recently recognised the need to align its Environmental Management System with the spirit and content of UNI EN ISO 14001: 2015 as fundamental to future development.

To this end the company undertook a wide-ranging review of all functions including development and design stages, material selection, usage and manufacturing processes.

The resulting definition of operational procedures in line with these aims and provisions has enabled Cembre S.p.A. to achieve Environmental Certification, further highlighting the companies sensitive and careful approach to environmental protection.

Cembre S.p.A. has recently enhanced its business processes with the certification by Lloyd's Register of Quality Assurance, of its Management System for the Health and Safety of Workers, in

accordance with the standard OHSAS18001:2007 (Occupational Health and Safety Management System).

The project, launched in early 2011, was strategically designed to facilitate the active participation of all employees at every level in the application of systems management, in order to optimise compliance of risk management capability with regard to laws and regulations concerning the health and safety of workers. All employees have received exhaustive training and are involved, by exercising their individual responsibility and competence, as key players in the identification of residual risk situations and the proposal of corrective solutions.

For Cembre then, this certification is not only the proper recognition of the quality of work performed, but also an incentive to maintain a determined competitive advantage in increasingly difficult and aggressive international markets.



All Cembre products comply with Directive 2011/65/EU of the European Parliament and Council dated 8 June 2011 (and subsequent amendment).



Cembre Ltd.
factory in Curdworth (Birmingham)



**Production
Units**



Cembre S.p.A. factory in Brescia (ITALY)
covers an area of approximately 121.000 sqm

Index

ELECTRICAL CONNECTORS

SYMBOL DESCRIPTION	4
PVC INSULATED CRIMP TERMINALS	6
FEMALE DISCONNECT TERMINALS	8
MALE DISCONNECT TERMINALS	8
MALE/FEMALE	8
BULLET AND SOCKET	8
BUTT AND PARALLEL CONNECTORS	9
BUTT CONNECTORS	9
CLOSE END CONNECTORS	9
HALOGEN FREE INSULATED TERMINALS	10
INSULATED CHAIN TERMINALS	12
REINFORCED PA 6.6 INSULATED TERMINALS	14
REINFORCED DISCONNECT TERMINALS	16
FEMALE CONNECTORS	16
MALE CONNECTORS	17
MALE TABS	17
CONNECTOR SLEEVES	17
PA6 INSULATED END SLEEVES	18
"TWIN" PA6 INSULATED END SLEEVES	19
POLYPROPYLENE INSULATED CHAIN END SLEEVES	20
UNINSULATED END SLEEVES	21
UNINSULATED TERMINALS	22
CRIMPING CONNECTORS ACCORDING TO DIN 46234	26
COPPER TUBE CRIMPING LUGS	28
RING TONGUE TERMINALS WITH CONTAINED PALM	30
COPPER TUBE CRIMPING LUGS	31
COPPER TUBE CRIMPING LUGS ANGLED 90°	32
COPPER TUBE CRIMPING LUGS	33
COPPER TUBE CRIMPING LUGS ANGLED 315° AND 345°	35
HEAVY DUTY COPPER TUBE TERMINALS	36
THROUGH CONNECTORS	38
PARALLEL CONNECTORS	38
POLYAMIDE PA6.6 INSULATED COPPER TUBE LUGS	39
POLYAMIDE PA6.6 INSULATED FORK TERMINALS	41
UNINSULATED FORK TERMINALS	41
POLYAMIDE PA6.6 INSULATED PIN TERMINALS	42
UNINSULATED PIN CONNECTORS	42
UNINSULATED ROUND PIN CONNECTORS	42
COPPER TUBE LUGS 4-ESI FIXING	43
COPPER TUBE CRIMPING LUGS ACCORDING TO DIN 46235	44
CRIMPING THROUGH CONNECTORS	45
ACCORDING TO DIN 46267 T.1	45
COPPER TUBE CRIMPING LUGS	46
CRIMPING THROUGH CONNECTORS	47
COPPER TUBE CRIMPING LUGS ACCORDING TO NF C20-130	48
COPPER TUBE CRIMPING LUGS ANGLED 90°	49
CRIMPING THROUGH CONNECTORS	49
COLOUR CODED COPPER CRIMPING LUGS	50
COLOUR CODED SPLICES	54
SLEEVE CONNECTORS	55
MECHANICAL FIXING LUGS	56
CABLE CLAMPS	57
HIGH VOLTAGE COPPER TERMINALS	58
HIGH VOLTAGE TERMINALS	59
HIGH VOLTAGE STALK CONNECTORS	60
HIGH VOLTAGE COPPER THROUGH CONNECTORS	61
ALUMINIUM TERMINALS	62
THROUGH CONNECTORS	63
REDUCER THROUGH CONNECTORS	63
BIMETALLIC CONNECTORS	64
MECHANICAL LUGS	65
MECHANICAL LUGS WITH SYMMETRICAL PALM	66
MECHANICAL SPLICES	66

TERMINAL BLOCKS, FLEXIBLE BUS-BAR AND BRAIDS

SYMBOL DESCRIPTION	68
EXAMPLE APPLICATIONS	69
SINGLE POLE TERMINAL BLOCKS	70
CONNECTING CAPACITY OF TERMINAL BLOCKS	72
POWER DISTRIBUTION BLOCK	74
CONNECTING CAPACITY OF POWER DISTRIBUTION BLOCK	75
ONE WAY TERMINAL BLOCKS	76
TERMINAL BLOCK TYPE EKL	77
TERMINAL BLOCK TYPE ZS	77
INSULATED FLEXIBLE BUSBAR	78
FLEXIBLE BRAIDS	80

CABLE GLANDS AND ACCESSORIES

SYMBOL DESCRIPTION	82
RANGE OVERVIEW	83
MAXIBLOCK CABLE GLANDS	84
SPIRALBLOCK CABLE GLANDS	88
MAXIBLOCK ATEX CABLE GLANDS	89
COMPRESSION CABLE GLANDS	90
POLYSTYRENE CABLE GLANDS	91
MAXIBRASS CABLE GLANDS	92
MAXIBRASS ATEX CABLE GLANDS	96
EMC CABLE GLANDS	96
COMPRESSION CABLE GLANDS	97
MAXINOX CABLE GLANDS	98
LOCKNUTS WITH COLLAR	100
LOCKNUTS WITHOUT COLLAR	101
LOCKNUTS	102
EMC LOCKNUTS	103
MAXINOX LOCKNUTS	103
INTERNAL PLUGS FOR CABLE GLANDS	104
MULTI-ENTRY SEALS FOR CABLE GLANDS	105
MULTI-ENTRY SEAL PLUGS FOR CABLE GLANDS	105
ENTRY THREAD ADAPTERS	106
ACCESSORIES	108
SEALING RINGS	109
ENTRY PLUGS	112
ENTRY BUSHES	114
ENTRY PLUGS	115
ENTRY BUSHES	115
RUTASEAL GROMMETS	116
MODULAR RETAINING CLIPS	116

MECHANICAL AND PNEUMATIC TOOLS

SYMBOL DESCRIPTION	118
MECHANICAL TOOLS CRIMPSTAR® RANGE	120
MECHANICAL TOOLS ND® RANGE	128
MECHANICAL TOOLS ZKE RANGE	129
MECHANICAL TOOLS HP4 RANGE	130
MECHANICAL TOOL HWE1	132
MECHANICAL TOOL MLRJ1	132
MECHANICAL TOOL IDT	133
MECHANICAL TOOLS TN RANGE	134
MECHANICAL TOOLS TND RANGE	136
CABLE CUTTERS KT RANGE	137
WIRE STRIPPERS HB RANGE	138
PROFESSIONAL SCISSORS SC RANGE	138
CABLE STRIPPING TOOLS HB RANGE	139
HAND TOOLS	140
FRAME-TYPE HOLE PUNCHING TOOL	140

BENCH PRESS TOOLS

BENCH PRESS TOOL	142
ELECTRO-PNEUMATIC BENCH PRESS	144
PNEUMATIC CRIMPING TOOLS	145
BENCH PRESS	146

HYDRAULIC CRIMPING TOOLS AND CUTTERS

SYMBOL DESCRIPTION	148
HYDRAULIC CRIMPING TOOLS AND PRESSHEADS	150
HYDRAULIC CUTTING TOOLS AND HEADS	166
FRAME-TYPE HOLE PUNCHING HEAD	175
PIERCING HEADS	175
PULLER-TYPE HOLE PUNCHING TOOLS	176
HOLE PUNCHING KIT	176
PULLER-TYPE HOLE PUNCHING HEAD	177
NUT SPLITTING HEADS	178

CORDLESS HYDRAULIC TOOLS

SYMBOL DESCRIPTION	180
18.0 V - 5.2 AH CORDLESS TOOL FEATURES	182
18.0 V - 2.0 AH CORDLESS TOOL FEATURES	183
18.0 V CORDLESS HYDRAULIC CRIMPING TOOLS	184
18.0 V CORDLESS HYDRAULIC CUTTING TOOLS	198
18.0 V CORDLESS HYDRAULIC FRAME-TYPE HOLE PUNCHING TOOL	211
18.0 V CORDLESS HYDRAULIC PULLER-TYPE HOLE PUNCHING TOOL	212
KIT FOR HOLE PUNCHING	214
PUNCHING ACCESSORIES AVAILABLE	215
PRESSURE TEST DEVICE	216

HYDRAULIC PUMPS AND UNITS

HYDRAULIC PUMPS	218
PORTABLE ELECTRO-HYDRAULIC PUMPS	220
PORTABLE ELECTRO-HYDRAULIC PUMPS B70M-P24 RANGE	222
ACCESSORIES FOR B70M-P24	224
HYDRAULIC UNITS	225
HYDRAULIC CUTTING UNITS	227
PORTABLE BATTERY HYDRAULIC CUTTING UNITS	229
FLEXIBLE HOSES	230
QUICK COUPLERS	230

MARKETLINE PRODUCTS

CABLE TIES	232
ACCESSORIES	236
INSULATED COVERS	237
TERMOCOIL HEAT-SHRINKABLE TUBING	238
TERMOSTRIP HEAT-SHRINKABLE TUBING	240
TERMOBLOCK HEAT-SHRINKABLE TUBING	242
CAST RESIN JOINTS	243
MECHANICAL TOOLS	245
CABLE TIE TOOLS	246
TAPE RULES	246

DIE SELECTOR CHART

DIE SELECTOR CHART	248
DIE SELECTOR CHART FOR DEEP STEPPED INDENTING WITH CONTAINING DIES	253
DIE SELECTOR CHART	255
MUT DIES CROSS REFERENCE CHART	260
RHU600 DIES CROSS REFERENCE CHART	261
RHU1000 DIES CROSS REFERENCE CHART	262

APPENDIX





















TYPE/CODE CROSS-REFERENCE CHART	264
COMPARISON OF AWG, MCM AND METRIC CONDUCTOR CROSS SECTIONS	274
IEC 60228 : 2004 - 11 CONDUCTOR TABLES	275
SYSTEM OF DENOMINATION OF HARMONISED CABLES ACCORDING TO CENELEC HD 361	278
UL AND VDE MARKING OF CABLE GLANDS	279
INGRESS PROTECTION (IP) RATING ACCORDING TO EN 60529 - CEI 70-1	280
FLAMMABILITY TEST FOR PRODUCTS AND MATERIALS	281
RECOMMENDED TORQUE SETTINGS FOR CABLE GLANDS	281
NEW HAND TOOL RANGE	282
NOTES	284

ELECTRICAL CONNECTORS



symbol description

electrical connectors

	Insulation sleeve in Polyvinylchloride		Aluminium connectors of a purity equal to or greater than 99,5%.
	Insulation sleeve in Polycarbonate		Aldrey connectors
	Insulation sleeve in Nylon PA6.6		Zinc Plated Steel connectors
	Insulation sleeve in Polyethylene High Density		Internal surface is filled with special grease so as to avoid oxidation of the connector
	Heat shrinkable		Connector provided with central stop
	Insulation sleeve form to allow easy "introduction" of the conductor		Colour coded connectors
	Manufactured from electrolytic Copper strip with a purity greater than 99,9%		Facilitated introduction of the conductor
	Manufactured from Brass strip with a purity greater than 99,9%		Inspection hole for checking the correct introduction of the conductor
	Manufactured from electrolytic Copper tube with a purity greater than 99,9%		Contained palm connectors
	Manufactured from electrolytic Copper wire with a purity greater than 99,9%		Annealed material
	Brazed seam		Electrolytically tin plated to avoid oxidation; min 3µm
	Brass connectors		Lugs angled
	Bimetallic connectors, Aluminium and Copper.		Zinc Plated Steel screws

symbol description

electrical connectors



Zinc Plated Steel nuts



Operating temperature range



Hexagonal crimp



Degree of protection



Radial crimp



UL LISTING Marking valid in USA & CANADA



Indent crimp



UL LISTING Marking valid in USA & CANADA



Deep indent crimp



In accordance with DIN 46235



"W" crimp



Meets the requirements for fire testing of materials and components for trains EN 45545-2:2013



Oval crimp



Halogen free



Trapezium crimp



Circular crimp



Semicircular crimp



Indent crimp



F range funnel entry - for Copper conductors



The unique funnel shaped PVC sleeve guarantees total insertion of the conductor strands into the terminal barrel, creating a secure and reliable, electrical and mechanical connection.

The operating temperature range is -20 to +80°C (Surge +90°C). Recommended crimping tools are shown on pages 120 to 143, 184, 245.

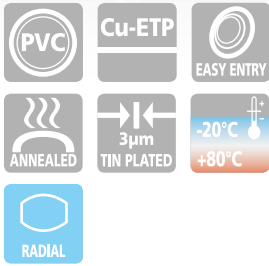

The internal surface of the barrel is rifled to improve contact with conductor strands when crimped and to increase tensile strength.

The "F" range of terminals offers a wide selection of rings, forks, pins and blades, designed to meet the ever changing end user requirements.



pin terminals

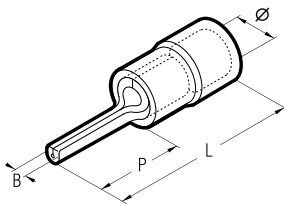

blade terminals

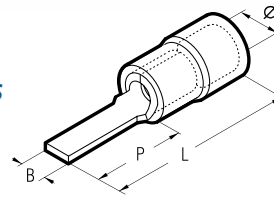

Conductor Size sqmm (AWG)	Type	Dimensions mm				Quantity Box/Bag
		Ø	B	P	L	
0,25÷1,5 (22÷16)	RF-P8	4,0	1,6	8,0	17,8	3.000/100
	RF-P10	4,0	1,6	10,0	19,8	3.000/100
	RF-P12	4,0	1,6	12,0	22,0	3.000/100
1,5÷2,5 (16÷14)	BF-P8	4,9	1,7	8,0	17,8	2.500/100
	BF-P10	4,9	1,8	10,0	19,8	2.500/100
	BF-P12	4,9	1,8	12,0	21,8	2.500/100
4÷6 (12÷10)	GF-P10	6,6	2,2	10,0	24,5	1.000/100
	GF-P12	6,6	2,2	12,0	26,7	1.000/100
	GF-P14	6,6	2,2	14,0	28,7	1.000/100

Conductor Size sqmm (AWG)	Type	Dimensions mm				Quantity Box/Bag
		Ø	B	P	L	
0,25÷1,5 (22÷16)	RF-PP12	4,0	3,0	12,8	22,8	3.000/100
	RF-PP12/1	4,0	3,0	11,3	21,3	3.000/100
	RF-PP12/19	4,0	1,9	13,2	23,2	3.000/100
	RF-PP12/23	4,0	2,3	13,2	23,2	2.500/100
	RF-PP14	4,0	3,0	14,8	24,8	2.500/100
	RF-PP16/23	4,0	2,3	17,2	27,2	2.500/100
1,5÷2,5 (16÷14)	BF-PP10	4,9	3,5	10,0	20,0	2.500/100
	BF-PP12	4,9	3,5	12,8	22,8	2.500/100
	BF-PP12/25	4,9	2,5	13,3	23,3	2.000/100
	BF-PP12/29*	4,9	2,9	13,3	23,3	2.500/100
	BF-PP16/25	4,9	2,5	17,2	27,2	2.500/100
	GF-PP12	6,6	4,0	13,3	27,4	1.000/100
4÷6 (12÷10)	GF-PP17	6,6	2,9	19,2	33,3	1.000/100

hooked blade terminals

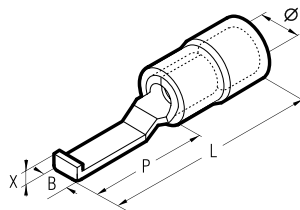

Conductor Size sqmm (AWG)	Type	Dimensions mm					Quantity Box/Bag
		Ø	B	P	L	X	
0,25÷1,5 (22÷16)	RF-PPL30*	4,0	3,0	17,5	28,3	1,7	2.500/100
	RF-PPL46*	4,0	4,6	17,5	28,3	1,7	2.500/100
1,5÷2,5 (16÷14)	BF-PPL30*	4,9	3,0	17,5	28,3	1,7	2.000/100
	BF-PPL46*	4,9	4,6	17,5	28,3	1,7	2.000/100
4÷6 (12÷10)	GF-PPL46*	6,6	4,6	17,5	32,6	1,9	1.000/100

*Not UL approved

PVC INSULATED CRIMP TERMINALS

RF BF GF

F range funnel entry - for Copper conductors



VALSTAR-V3-F



Robust plastic case with compartments, containing:

- An assortment of PVC insulated crimp terminals for conductor sizes 0,25 to 6 mm² (22÷10 AWG).
- Tool Crimpstar® HP 3.

Connectors included:

- Qty 50 terminals RF-U4
- Qty 50 terminals RF-U5
- Qty 50 terminals RF-P10
- Qty 50 terminals BF-U4
- Qty 50 terminals BF-U5
- Qty 50 terminals BF-P10
- Qty 25 terminals GF-U5
- Qty 25 terminals GF-U6
- Qty 25 terminals GF-P12
- Qty 25 connectors PL06-M
- Qty 25 connectors PL1-M

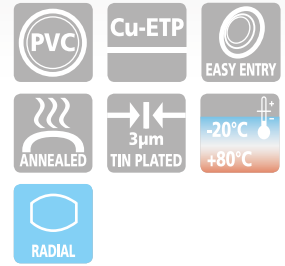

ring terminals

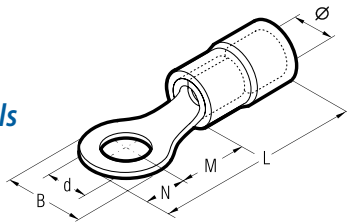

fork/spade terminals

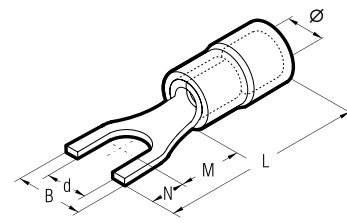

Conductor Size sqmm (AWG)	Ø Stud mm	Type	Dimensions mm						Quantity Box/Bag
			Ø	B	M	N	L	d	
0,25÷1,5 (22÷16)	2	RF-M2**	4,0	5,6	4,5	2,8	17,3	2,2	3.000/100
	3	RF-M3	4,0	5,6	4,5	2,8	17,3	3,2	3.000/100
	3,5	RF-M3.5	4,0	5,6	4,5	2,8	17,3	3,7	3.000/100
	3,5	RF-M3.5/1	4,0	6,2	7,1	3,1	20,2	3,7	3.000/100
	4	RF-M4	4,0	7,0	6,5	3,5	20,0	4,3	3.000/100
	4	RF-M4/3*	4,0	7,8	7,1	3,9	21,0	4,3	3.000/100
	5	RF-M5	4,0	7,8	7,1	3,9	21,0	5,3	2.500/100
	6	RF-M6	4,0	9,4	8,1	4,7	22,8	6,4	2.500/100
	6	RF-M6/1	4,0	12,0	10,3	6,0	26,3	6,4	2.000/100
	7	RF-M7	4,0	9,4	8,1	4,7	22,8	7,2	2.500/100
	8	RF-M8	4,0	12,0	10,3	6,0	26,3	8,4	2.000/100
	10	RF-M10	4,0	15,5	13,0	7,7	30,8	10,5	1.500/100
12	RF-M12	4,0	18,0	15,5	9,0	34,5	13,0	1.500/100	
1,5÷2,5 (16÷14)	2	BF-M2**	4,9	5,6	5,0	2,8	17,8	2,2	3.000/100
	3	BF-M3	4,9	5,6	5,0	2,8	17,8	3,2	2.500/100
	3,5	BF-M3.5	4,9	5,6	5,0	2,8	17,8	3,7	2.500/100
	3,5	BF-M3.5/1	4,9	6,2	6,5	3,1	19,6	3,7	2.500/100
	4	BF-M4	4,9	8,0	6,5	4,0	20,5	4,3	2.500/100
	5	BF-M5	4,9	8,0	7,5	4,0	21,5	5,3	2.000/100
	6	BF-M6	4,9	9,4	8,6	4,7	23,3	6,4	2.000/100
	6	BF-M6/1	4,9	12,0	10,3	6,0	26,3	6,4	2.000/100
	6	BF-M6/2**	4,9	8,4	5,4	4,2	19,6	6,4	2.500/100
	7	BF-M7	4,9	10,0	7,8	5,0	22,8	7,2	2.000/100
	8	BF-M8	4,9	12,0	10,3	6,0	26,3	8,4	1.500/100
	10	BF-M10	4,9	15,5	13,0	7,7	30,8	10,5	1.500/100
12	BF-M12	4,9	18	15,5	9,0	34,5	13,0	1.000/100	
4÷6 (12÷10)	3	GF-M3	6,6	8,0	8,1	4,0	26,2	3,2	1.000/100
	3,5	GF-M3.5	6,6	8,0	8,1	4,0	26,2	3,7	1.000/100
	4	GF-M4	6,6	9,0	8,1	4,5	26,7	4,3	1.000/100
	5	GF-M5	6,6	9,0	8,1	4,5	26,7	5,3	1.000/100
	6	GF-M6	6,6	11,0	11,1	5,5	30,7	6,4	1.000/100
	6	GF-M6/1	6,6	11,0	8,1	5,5	27,7	6,4	1.000/100
	7	GF-M7	6,6	11,0	11,1	5,5	30,7	7,2	1.000/100
	8	GF-M8	6,6	13,6	12,1	6,8	33,0	8,4	800/100
	8	GF-M8/1**	6,6	11,0	8,1	5,5	27,7	8,4	1.000/100
	10	GF-M10	6,6	13,6	12,1	6,8	33,0	10,5	800/100
	10	GF-M10/1	6,6	15,5	13,8	7,7	35,7	10,5	1.000/100
	12	GF-M12	6,6	19,0	15,1	9,5	38,7	13,0	500/100
	14	GF-M14	6,6	21,0	16,1	10,5	40,7	15,0	500/100
	16	GF-M16	6,6	24,0	17,1	12,0	43,2	17,0	500/100

Conductor Size sqmm (AWG)	Ø Stud mm	Type	Dimensions mm						Quantity Box/Bag
			Ø	B	M	N	L	d	
0,25÷1,5 (22÷16)	3	RF-U3	4,0	5,5	5,5	4,0	19,5	3,2	3.000/100
	3,5	RF-U3.5	4,0	6,0	6,5	3,8	20,3	3,7	3.000/100
	3,5	RF-U3.5/1	4,0	7,2	6,5	3,8	20,3	3,7	3.000/100
	3,5	RF-U3.5/2*	4,0	6,4	6,5	3,8	20,3	3,7	3.000/100
	4	RF-U4	4,0	6,5	7,5	3,7	21,2	4,3	3.000/100
	4	RF-U4/1	4,0	8,5	7,5	3,7	21,2	4,3	3.000/100
	4	RF-U4/2	4,0	7,5	7,5	3,7	21,2	4,3	3.000/100
	5	RF-U5	4,0	8,5	7,5	3,7	21,2	5,3	2.500/100
	5	RF-U5/1**	4,0	9,4	7,5	3,7	21,2	5,3	3.000/100
	6	RF-U6	4,0	9,4	8,1	4,7	22,8	6,4	2.000/100
	6	RF-U6/1	4,0	12,0	9,2	7,1	26,3	6,4	2.000/100
	8	RF-U8	4,0	14,0	10,0	6,3	26,3	8,4	2.000/100
10	RF-U10	4,0	17,5	13,0	7,7	30,8	10,5	1.500/100	
12	RF-U12	4,0	20,0	15,5	9,0	34,5	13,0	1.500/100	
1,5÷2,5 (16÷14)	3	BF-U3	4,9	5,5	5,5	4,0	19,5	3,2	2.500/100
	3,5	BF-U3.5	4,9	6,4	6,5	3,8	20,3	3,7	2.500/100
	3,5	BF-U3.5/1*	4,9	7,2	6,5	3,8	20,3	3,7	3.000/100
	4	BF-U4	4,9	6,5	7,5	3,7	21,2	4,3	2.500/100
	4	BF-U4/1	4,9	8,5	7,5	3,7	21,2	4,3	2.000/100
	4	BF-U4/2	4,9	7,5	7,5	3,7	21,2	4,3	2.000/100
	5	BF-U5	4,9	8,5	7,5	3,7	21,2	5,3	2.000/100
	5	BF-U5/2*	4,9	12,0	11,3	5,0	26,3	5,3	1.500/100
	6	BF-U6	4,9	9,4	8,1	4,7	22,8	6,4	2.000/100
	6	BF-U6/1	4,9	12,0	9,2	7,1	26,3	6,4	2.000/100
	8	BF-U8	4,9	14,0	10,0	6,3	26,3	8,4	1.500/100
	10	BF-U10	4,9	17,5	13,0	7,7	30,8	10,5	1.000/100
12	BF-U12	4,9	20,0	15,5	9,0	34,5	13,0	1.500/100	
4÷6 (12÷10)	3,5	GF-U3.5	6,6	7,5	8,5	3,9	26,5	3,7	1.000/100
	4	GF-U4	6,6	7,5	8,0	4,4	26,5	4,3	1.000/100
	5	GF-U5	6,6	9,5	8,0	4,4	26,5	5,3	1.000/100
	6	GF-U6	6,6	10,0	11,0	5,5	30,6	6,4	1.000/100
	8	GF-U8	6,6	13,5	12,0	8,0	34,1	8,4	1.000/100
	10	GF-U10	6,6	15,5	13,0	8,0	35,1	10,5	1.000/100
	10	GF-U10/1	6,6	17,5	13,8	7,7	35,7	10,5	1.000/100
	12	GF-U12	6,6	21,0	15,1	9,5	38,7	13,0	500/100
14	GF-U14	6,6	23,0	16,1	10,5	40,7	15,0	500/100	
16	GF-U16	6,6	26,0	17,1	11,5	42,7	17,0	500/100	

*Not UL approved **Made to order

RF-F BF-F GF-F

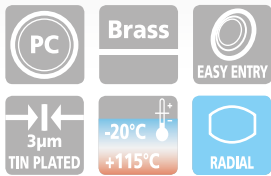

Recommended crimping tools are shown on pages 120 to 143, 184, 245.

Polycarbonate insulated terminals partially reinforced with Copper sleeve

Conductor Size sqmm (AWG)	Type	Tab Size mm	Quantity Box/Bag
0,25÷1,5 (22÷16)	RF-F305	2,8 x 0,5	3.000/100
	RF-F308*	2,8 x 0,8	3.000/100
	RF-F405	4,8 x 0,5	2.500/100
	RF-F408	4,8 x 0,8	2.500/100
1,5÷2,5 (16÷14)	BF-F405	4,8 x 0,5	2.500/100
	BF-F408	4,8 x 0,8	2.500/100
	GF-F608	6,35 x 0,8	1.500/100
4÷6 (12÷10)	GF-F608	6,35 x 0,8	1.000/100

Polycarbonate fully insulated terminals partially reinforced with Copper sleeve

Conductor Size sqmm (AWG)	Type	Tab Size mm	Quantity Box/Bag
0,25÷1,5 (22÷16)	RF-F305P	2,8 x 0,5	2.000/100
	RF-F308P*	2,8 x 0,8	2.000/100
	RF-F405P	4,8 x 0,5	1.500/100
	RF-F408P	4,8 x 0,8	1.500/100
1,5÷2,5 (16÷14)	BF-F405P	4,8 x 0,5	1.500/100
	BF-F408P	4,8 x 0,8	1.500/100
	GF-F608P	6,35 x 0,8	1.000/100
4÷6 (12÷10)	GF-F608P	6,35 x 0,8	800/100



RF-M BF-M GF-M

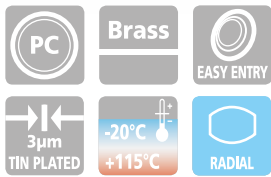

Recommended crimping tools are shown on pages 120 to 143, 184, 245.

Polycarbonate insulated terminals partially reinforced with Copper sleeve

Conductor Size sqmm (AWG)	Type	Tab Size mm	Quantity Box/Bag
0,25÷1,5 (22÷16)	RF-M608	6,35 x 0,8	3.000/100
1,5÷2,5 (16÷14)	BF-M608	6,35 x 0,8	2.000/100
4÷6 (12÷10)	GF-M608	6,35 x 0,8	1.000/100

Polycarbonate fully insulated terminals partially reinforced with Copper sleeve

Conductor Size sqmm (AWG)	Type	Tab Size mm	Quantity Box/Bag
0,25÷1,5 (22÷16)	RF-M608P	6,35 x 0,8	1.000/100
1,5÷2,5 (16÷14)	BF-M608P	6,35 x 0,8	800/100



RF-FM BF-FM RF-B BF-B

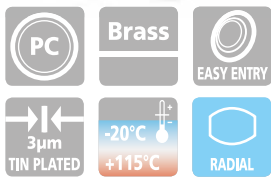

Recommended crimping tools are shown on pages 120 to 143, 184, 245.

Polycarbonate insulated terminals partially reinforced with Copper sleeve

Conductor Size sqmm (AWG)	Type	Tab Size mm	Quantity Box/Bag
0,25÷1,5 (22÷16)	RF-FM608	6,35 x 0,8	1.000/100
1,5÷2,5 (16÷14)	BF-FM608	6,35 x 0,8	1.000/100

Polycarbonate insulated terminals partially reinforced with Copper sleeve

Conductor Size sqmm (AWG)	Type	Ø mm	Quantity Box/Bag
0,25÷1,5 (22÷16)	RF-BM4*	4	2.500/100
	RF-BF4*	4	800/100
1,5÷2,5 (16÷14)	BF-BM5*	5	2.000/100
	BF-BF5*	5	800/100



*Not UL approved

FEMALE DISCONNECT TERMINALS

for Copper conductors

MALE DISCONNECT TERMINALS

for Copper conductors

BULLET AND SOCKET

for Copper conductors

BUTT AND PARALLEL CONNECTORS

for Copper conductors



butt connectors

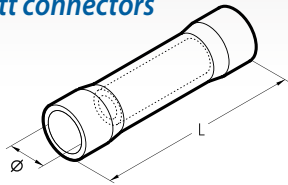

parallel connectors

Recommended crimping tools are shown on pages 120 to 143, 184, 245.

PVC insulated

Conductor Size sqmm (AWG)	Type	Ø mm	L mm	Quantity Box/Bag
0,25÷0,5 (24÷20)	PL01-M*	3,0	25,0	3.000/100
0,25÷1,5 (22÷16)	PL03-M	4,0	25,0	1.000/100
1,5÷2,5 (16÷14)	PL06-M	5,0	25,0	1.500/100
4÷6 (12÷10)	PL1-M	6,5	32,0	500/100
0,25÷1,5 (22÷16)	PL03-P*	4,0	20,0	3.000/100
1,5÷2,5 (16÷14)	PL06-P*	5,0	16,0	2.000/100

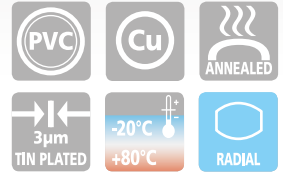

BUTT CONNECTORS

for Copper conductors

Recommended crimping tools are shown on pages 120 to 143, 184, 245.

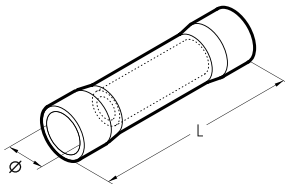

Polyamide PA6.6 insulated

Conductor Size sqmm (AWG)	Type	Ø mm	L mm	Quantity Box/Bag
0,25÷1,5 (22÷16)	NL03-M	4,0	25,0	1.000/100
1,5÷2,5 (16÷14)	NL06-M	5,4	25,5	1.500/100
4÷6 (12÷10)	NL1-M	7,6	32,0	500/100
10 (8÷7)	NL2-M	8,0	43,0	500/100
16 (6÷5)	NL3-M	9,2	44,0	500/100



Recommended crimping tools are shown on pages 122, 133.

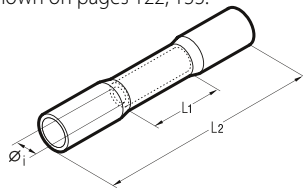

PE HD insulated, heat shrinkable

Conductor Size sqmm (AWG)	Type	Ø mm	L1 mm	L2 mm	Quantity Box/Bag
0,25÷1,5 (22÷16)	WL03-M	1,7	15,0	36,0	1.500/100
1,5÷2,5 (16÷14)	WL06-M	2,3	15,0	36,5	1.000/100
4÷6 (12÷10)	WL1-M	3,4	15,0	41,0	500/100

- Max operating voltage: 600 V
- Shrink temperature: 150 °C
- Protection: IP68



CLOSE END CONNECTORS

for Copper conductors

Recommended crimping tools are shown on pages 120 to 143, 184, 245.

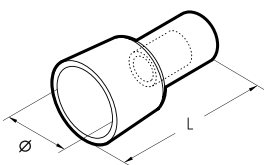

Polyamide PA6.6 insulated

Conductor Size sqmm (AWG)	Type	Ø mm	L mm	Quantity Box/Bag
0,25÷1,5 (22÷16)	NL03-P	7,9	21,0	1.000/100
1,5÷2,5 (16÷14)	NL06-P	7,9	19,9	1.000/100
4÷6 (12÷10)	NL06-PB	6,5	13,6	1.500/100
10 (8÷7)	NL1-P	10,5	21,5	500/100
16 (6÷5)	NL1-PG	9,0	17,8	1.000/100

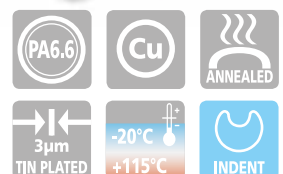

*Not UL approved

VP RP BP GP

HALOGEN FREE INSULATED TERMINALS

P range funnel entry - for Copper conductors



The "P" range of terminals has been designed, to meet the increasing demands for improved safety and reliability of electrical connectors.

The Polycarbonate insulation, is a Halogen free, self extinguishing thermoplastic material class V0 (UL 94). The unique funnel shaped entry of the insulation sleeve, guarantees to-

tal insertion of the conductor strands into the terminal barrel, creating a secure and reliable, electrical and mechanical connection.



The operating temperature range is -20 to +115°C (Surge +130°C). Recommended crimping tools are shown on pages 120 to 143, 184, 245.

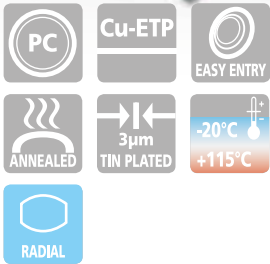

pin terminals

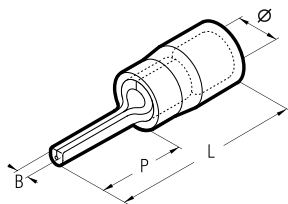

Conductor Size sqmm (AWG)	Type	Dimensions mm				Quantity Box/Bag
		Ø	B	P	L	
0,2÷0,5 (24÷20)	VP-P10	3,0	1,0	9,8	20,2	4.000/100
	RP-P8	4,0	1,6	7,8	17,9	3.000/100
0,25÷1,5 (22÷16)	RP-P10	4,0	1,6	9,8	19,9	3.000/100
	RP-P12	4,0	1,6	12,0	22,1	3.000/100
1,5÷2,5 (16÷14)	BP-P8	4,9	1,7	7,8	17,9	3.000/100
	BP-P10	4,9	1,8	9,8	19,9	3.000/100
	BP-P12	4,9	1,8	11,8	21,9	2.500/100
4÷6 (12÷10)	GP-P10	6,6	2,2	10,4	24,5	1.000/100
	GP-P12	6,6	2,2	12,6	26,7	1.000/100
	GP-P14	6,6	2,2	14,6	28,7	1.000/100

blade terminals

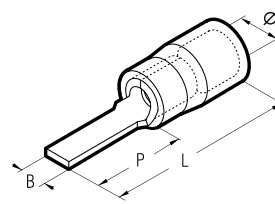

Conductor Size sqmm (AWG)	Type	Dimensions mm				Quantity Box/Bag
		Ø	B	P	L	
0,2÷0,5 (24÷20)	VP-PP12/19	3,0	1,9	12,4	22,4	4.000/100
	RP-PP12	4,0	3,0	12,8	22,9	3.000/100
0,25÷1,5 (22÷16)	RP-PP12/1	4,0	3,0	11,3	21,4	3.000/100
	RP-PP12/19	4,0	1,9	13,2	23,3	3.000/100
	RP-PP12/23	4,0	2,3	13,2	23,3	2.500/100
	RP-PP14	4,0	3,0	14,8	24,9	2.500/100
	RP-PP16/23	4,0	2,3	17,2	27,3	2.500/100
1,5÷2,5 (16÷14)	BP-PP12	4,9	3,5	12,8	22,9	2.500/100
	BP-PP12/25	4,9	2,5	13,3	23,4	2.000/100
	BP-PP12/29	4,9	2,9	13,3	23,4	2.500/100
	BP-PP16/25	4,9	2,5	17,2	27,3	2.500/100
4÷6 (12÷10)	GP-PP12	6,6	4,0	13,3	27,4	1.000/100
	GP-PP17	6,6	2,9	19,1	33,2	1.000/100

hooked blade terminals

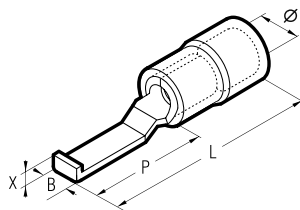

Conductor Size sqmm (AWG)	Type	Dimensions mm					Quantity Box/Bag
		Ø	B	P	L	X	
0,25÷1,5 (22÷16)	RP-PPL30*	4,0	3,0	17,5	28,3	1,7	3.000/100
	RP-PPL46*	4,0	4,6	17,5	28,3	1,7	3.000/100
1,5÷2,5 (16÷14)	BP-PPL30*	4,9	3,0	17,5	28,3	1,7	2.500/100
	BP-PPL46*	4,9	4,6	17,5	28,8	1,7	2.500/100
4÷6 (12÷10)	GP-PPL46*	6,6	4,6	17,5	32,6	1,9	1.000/100

*Not UL approved

HALOGEN FREE INSULATED TERMINALS

P range funnel entry - for Copper conductors

VP RP
BP GP

ring terminals

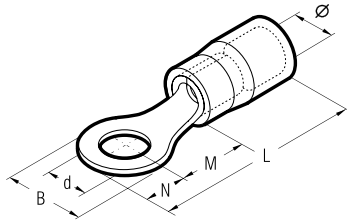

Cond. Size sqmm (AWG)	Ø Stud mm	Type	Dimensions mm						Quantity Box/Bag
			Ø	B	M	N	L	d	
0,25÷0,5 (24÷20)	3,0	2 VP-M2*	3,0	5,6	4,5	2,8	17,5	2,2	4.000/100
		3 VP-M3	3,0	5,6	4,5	2,8	17,5	3,2	4.000/100
		3,5 VP-M3.5	3,0	5,6	4,5	2,8	17,5	3,7	4.000/100
		4 VP-M4	3,0	7,0	6,5	3,5	20,2	4,3	4.000/100
		5 VP-M5	3,0	7,8	7,1	3,9	21,2	5,3	4.000/100
		6 VP-M6*	3,0	9,4	8,1	4,7	23,0	6,4	4.000/100
0,25÷1,5 (22÷16)	4,0	2 RP-M2*	4,0	5,6	4,5	2,8	17,4	2,2	3.000/100
		3 RP-M3	4,0	5,6	4,5	2,8	17,4	3,2	3.000/100
		3,5 RP-M3.5	4,0	5,6	4,5	2,8	17,4	3,7	3.000/100
		3,5 RP-M3.5/1	4,0	6,2	7,1	3,1	20,2	3,7	3.000/100
		4 RP-M4	4,0	7,0	6,5	3,5	20,1	4,3	3.000/100
		4 RP-M4/3	4,0	7,8	7,1	3,9	21,1	4,3	3.000/100
		5 RP-M5	4,0	7,8	7,1	3,9	21,1	5,3	3.000/100
		6 RP-M6	4,0	9,4	8,1	4,7	22,9	6,4	2.500/100
		6 RP-M6/1	4,0	12,0	10,3	6,0	26,4	6,4	2.000/100
		7 RP-M7	4,0	9,4	8,1	4,7	22,9	7,2	2.500/100
		8 RP-M8	4,0	12,0	10,3	6,0	26,4	8,4	2.500/100
		10 RP-M10	4,0	15,5	13,0	7,7	30,9	10,5	2.000/100
12 RP-M12	4,0	18,0	15,5	9,0	34,6	13,0	2.000/100		
1,5÷2,5 (16÷14)	4,9	2 BP-M2*	4,9	5,6	5,0	2,8	17,9	2,2	2.500/100
		3 BP-M3	4,9	5,6	5,0	2,8	17,9	3,2	2.500/100
		3,5 BP-M3.5	4,9	5,6	5,0	2,8	17,9	3,7	3.000/100
		3,5 BP-M3.5/1	4,9	6,2	6,5	3,1	19,7	3,7	2.500/100
		4 BP-M4	4,9	8,0	6,5	4,0	20,6	4,3	2.500/100
		5 BP-M5	4,9	8,0	7,5	4,0	21,6	5,3	2.500/100
		6 BP-M6	4,9	9,4	8,6	4,7	23,4	6,4	2.000/100
		6 BP-M6/1	4,9	12,0	10,3	6,0	26,4	6,4	2.000/100
		6 BP-M6/2*	4,9	8,4	5,4	4,2	19,7	6,4	2.500/100
		7 BP-M7	4,9	10,0	7,8	5,0	22,9	7,2	2.500/100
		8 BP-M8	4,9	12,0	10,3	6,0	26,4	8,4	1.500/100
		10 BP-M10	4,9	15,5	13,0	7,7	30,9	10,5	1.500/100
12 BP-M12	4,9	18,0	15,5	9,0	34,6	13,0	1.500/100		
4÷6 (12÷10)	6,6	3 GP-M3	6,6	8,0	8,1	4,0	26,2	3,2	1.000/100
		3,5 GP-M3.5	6,6	8,0	8,1	4,0	26,2	3,7	1.500/100
		4 GP-M4	6,6	9,0	8,1	4,5	26,7	4,3	1.000/100
		5 GP-M5	6,6	9,0	8,1	4,5	26,7	5,3	1.000/100
		6 GP-M6	6,6	11,0	11,1	5,5	30,7	6,4	1.000/100
		6 GP-M6/1	6,6	11,0	8,1	5,5	27,7	6,4	1.000/100
		7 GP-M7	6,6	11,0	11,1	5,5	30,7	7,2	1.000/100
		8 GP-M8	6,6	13,6	12,1	6,8	33,0	8,4	800/100
		8 GP-M8/1*	6,6	11,0	8,1	5,5	27,7	8,4	1.000/100
		10 GP-M10	6,6	13,6	12,1	6,8	33,0	10,5	1.000/100
		10 GP-M10/1	6,6	15,5	13,8	7,7	35,7	10,5	1.000/100
		12 GP-M12	6,6	19,0	15,1	9,5	38,7	13,0	500/100
		14 GP-M14	6,6	21,0	16,1	10,5	40,7	15,0	500/100
		16 GP-M16	6,6	24,0	17,1	12,0	43,2	17,0	500/100

fork/spade terminals

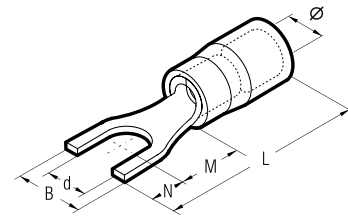

Cond. Size sqmm (AWG)	Ø Stud mm	Type	Dimensions mm						Quantity Box/Bag
			Ø	B	M	N	L	d	
0,25÷0,5 (24÷20)	3,0	3 VP-U3	3,0	5,5	5,5	4,0	18,7	3,2	4.000/100
		3,5 VP-U3.5	3,0	6,0	6,5	3,8	19,5	3,7	4.000/100
		4 VP-U4	3,0	6,5	7,5	3,7	20,4	4,3	4.000/100
		3 RP-U3	4,0	5,5	5,5	4,0	19,6	3,2	3.000/100
0,25÷1,5 (22÷16)	4,0	3,5 RP-U3.5	4,0	6,0	6,5	3,8	20,4	3,7	3.000/100
		3,5 RP-U3.5/2	4,0	6,4	6,5	3,8	20,4	3,7	3.000/100
		4 RP-U4	4,0	6,5	7,5	3,7	21,3	4,3	3.000/100
		4 RP-U4/1	4,0	8,5	7,5	3,7	21,3	4,3	3.000/100
		4 RP-U4/2	4,0	7,5	7,5	3,7	21,3	4,3	3.500/100
		5 RP-U5	4,0	8,5	7,5	3,7	21,3	5,3	3.000/100
		5 RP-U5/1*	4,0	9,4	7,5	3,7	21,3	5,3	3.000/100
		6 RP-U6	4,0	9,4	8,1	4,7	22,9	6,4	2.000/100
		6 RP-U6/1	4,0	12,0	9,2	7,1	26,4	6,4	2.000/100
		8 RP-U8	4,0	14,0	10,0	6,3	26,4	8,4	2.000/100
		10 RP-U10	4,0	17,5	13,0	7,7	30,9	10,5	1.500/100
		12 RP-U12	4,0	20,0	15,5	9,0	34,6	13,0	1.500/100
1,5÷2,5 (16÷14)	4,9	3 BP-U3	4,9	5,5	5,5	4,0	19,6	3,2	2.500/100
		3,5 BP-U3.5	4,9	6,4	6,5	3,8	20,4	3,7	2.500/100
		3,5 BP-U3.5/1*	4,9	7,2	6,5	3,8	20,4	3,7	2.500/100
		4 BP-U4	4,9	6,5	7,5	3,7	21,3	4,3	2.500/100
		4 BP-U4/1	4,9	8,5	7,5	3,7	21,3	4,3	3.000/100
		4 BP-U4/2	4,9	7,5	7,5	3,7	21,3	4,3	2.000/100
		5 BP-U5	4,9	8,5	7,5	3,7	21,3	5,3	2.000/100
		6 BP-U6	4,9	9,4	8,1	4,7	22,9	6,4	2.000/100
		6 BP-U6/1	4,9	12,0	9,2	7,1	26,4	6,4	2.000/100
		8 BP-U8	4,9	14,0	10,0	6,3	26,4	8,4	1.500/100
		10 BP-U10	4,9	17,5	13,0	7,7	30,9	10,5	1.000/100
		12 BP-U12	4,9	20	15,5	9,0	34,6	13,0	1.500/100
4÷6 (12÷10)	6,6	3,5 GP-U3.5	6,6	7,5	8,5	3,9	26,5	3,7	1.000/100
		4 GP-U4	6,6	7,5	8,0	4,4	26,5	4,3	1.000/100
		5 GP-U5	6,6	9,5	8,0	4,4	26,5	5,3	1.000/100
		6 GP-U6	6,6	10,0	11,0	5,5	30,6	6,4	1.000/100
		8 GP-U8	6,6	13,5	12,0	8,0	34,1	8,4	1.000/100
		10 GP-U10	6,6	15,5	13,0	8,0	35,1	10,5	1.000/100
		10 GP-U10/1	6,6	17,5	13,8	7,7	35,7	10,5	1.000/100
		12 GP-U12	6,6	21,0	15,1	9,5	38,7	13,0	500/100
		14 GP-U14	6,6	23,0	16,1	10,5	40,7	15,0	500/100
		16 GP-U16	6,6	26,0	17,1	11,5	42,7	17,0	500/100

*Made to order

CRP CBP CGP

INSULATED CHAIN TERMINALS

CP range with easy entry - for Copper conductors

The "CP" range of terminals has been designed to meet the increasing demands for improved safety and reliability of electrical connectors. Developed for use with production equipment, to give a quick and reliable

crimped joint, the Polycarbonate insulation is a Halogen free, self-extinguishing thermoplastic material class V0 (UL 94). The unique funnel shaped entry of the insulation sleeve guarantees to-

tal insertion of the conductor strands into the terminal barrel, creating a secure and reliable, electrical and mechanical connection. The operating temperature range is -20 to +115°C (Surge +130°C).

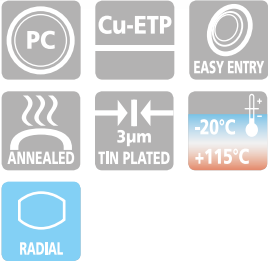

pin terminals

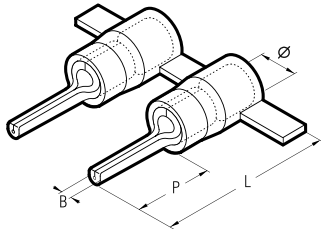

blade terminals

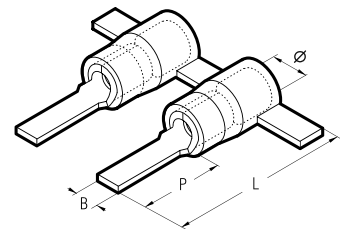

Conductor Size sqmm (AWG)	Type	Dimensions mm				Quantity
		Ø	B	P	L	
0,25÷1,5 (22÷16)	CRP-P8	4,0	1,6	8,0	17,9	2.000
	CRP-P10	4,0	1,6	10,0	19,9	2.000
	CRP-P12	4,0	1,6	12,0	22,1	2.000
1,5÷2,5 (16÷14)	CBP-P8	4,9	1,8	8,0	17,9	1.750
	CBP-P10	4,9	1,8	10,0	19,9	1.750
	CBP-P12	4,9	1,8	12,0	21,9	1.750
4÷6 (12÷10)	CGP-P10	6,6	2,2	10,0	24,5	1.250
	CGP-P12	6,6	2,2	12,0	26,7	1.250
	CGP-P14	6,6	2,2	14,0	28,7	1.250

Conductor Size sqmm (AWG)	Type	Dimensions mm				Quantity
		Ø	B	P	L	
0,25÷1,5 (22÷16)	CRP-PP12	4,0	3,0	12,8	22,9	2.000
	CRP-PP12/1*	4,0	3,0	11,3	21,4	2.000
	CRP-PP12/23*	4,0	2,3	13,2	23,3	2.000
	CRP-PP14	4,0	3,0	14,8	24,9	2.000
1,5÷2,5 (16÷14)	CBP-PP12	4,9	3,5	12,8	22,9	1.750
	CBP-PP12/25*	4,9	2,5	13,3	23,4	1.750
4÷6 (12÷10)	CGP-PP12	6,6	4,0	13,3	27,4	1.250
	CGP-PP17*	6,6	2,9	19,1	33,2	1.250

male disconnect terminals

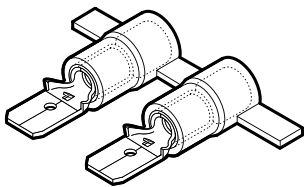

Conductor Size sqmm (AWG)	Type	Tab Size mm	Quantity
0,25÷1,5 (22÷16)	CRP-M608	6,35 x 0,8	2.000
1,5÷2,5 (16÷14)	CBP-M608	6,35 x 0,8	1.750
4÷6 (12÷10)	CGP-M608	6,35 x 0,8	1.250

female disconnect terminals

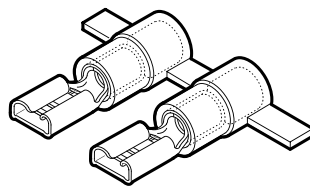

Conductor Size sqmm (AWG)	Type	Tab Size mm	Quantity
0,25÷1,5 (22÷16)	CRP-F305	2,8 x 0,5	2.000
	CRP-F308	2,8 x 0,8	2.000
	CRP-F405	4,8 x 0,5	2.000
	CRP-F408	4,8 x 0,8	2.000
	CRP-F608	6,35 x 0,8	2.000
1,5÷2,5 (16÷14)	CBP-F405	4,8 x 0,5	1.750
	CBP-F408	4,8 x 0,8	1.750
	CBP-F608	6,35 x 0,8	1.750
4÷6 (12÷10)	CGP-F608	6,35 x 0,8	1.250

female disconnect terminals fully insulated

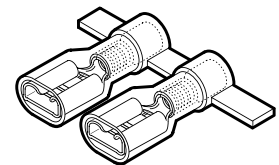

Conductor Size sqmm (AWG)	Type	Tab Size mm	Quantity
0,25÷1,5 (22÷16)	CRP-F405P*	4,8 x 0,5	2.000
	CRP-F408P*	4,8 x 0,8	2.000
	CRP-F608P*	6,35 x 0,8	1.500
1,5÷2,5 (16÷14)	CBP-F408P*	4,8 x 0,8	1.500
	CBP-F608P*	6,35 x 0,8	1.500
4÷6 (12÷10)	CGP-F608P*	6,35 x 0,8	1.250

*Not UL approved *Made to order

INSULATED CHAIN TERMINALS

CRP CBP CGP

CP range with easy entry - for Copper conductors

fork/spade terminals

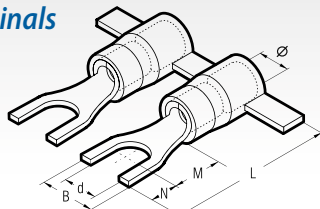

Cond. Size sqmm (AWG)	Ø Stud mm	Type	Dimensions mm					Quantity	
			Ø	B	M	N	L		d
0,25÷1,5 (22÷16)	3	CRP-U3	4,0	5,5	5,5	4,0	19,6	3,2	2.000
	3,5	CRP-U3.5	4,0	6,0	6,5	3,8	20,4	3,7	2.000
	3,5	CRP-U3.5/2*	4,0	6,4	6,5	3,8	20,4	3,7	2.000
	4	CRP-U4	4,0	6,5	7,5	3,7	21,3	4,3	2.000
	4	CRP-U4/1*	4,0	8,5	7,5	3,7	21,3	4,3	2.000
	4	CRP-U4/2*	4,0	7,5	7,5	3,7	21,3	4,3	2.000
	5	CRP-U5	4,0	8,5	7,5	3,7	21,3	5,3	2.000
	6	CRP-U6	4,0	9,4	8,1	4,7	22,9	6,4	2.000
1,5÷2,5 (16÷14)	6	CRP-U6/1*	4,0	12,0	9,2	7,1	26,4	6,4	2.000
	8	CRP-U8*	4,0	14,0	10,0	6,3	26,4	8,4	2.000
	3	CBP-U3	4,9	5,5	5,5	4,0	19,6	3,2	1.750
	3,5	CBP-U3.5	4,9	6,4	6,5	3,8	20,4	3,7	1.750
	4	CBP-U4	4,9	6,5	7,5	3,7	21,3	4,3	1.750
	4	CBP-U4/1*	4,9	8,5	7,5	3,7	21,3	4,3	1.750
	4	CBP-U4/2*	4,9	7,5	7,5	3,7	21,3	4,3	1.750
	5	CBP-U5	4,9	8,5	7,5	3,7	21,3	5,3	1.750
4÷6 (12÷10)	6	CBP-U6	4,9	9,4	8,1	4,7	22,9	6,4	1.750
	3,5	CGP-U3.5*	6,6	7,5	8,5	3,9	26,5	3,7	1.250
	4	CGP-U4*	6,6	7,5	8,0	4,4	26,5	4,3	1.250
	5	CGP-U5	6,6	9,5	8,0	4,4	26,5	5,3	1.250
6	CGP-U6	6,6	10,0	11,0	5,5	30,6	6,4	1.250	

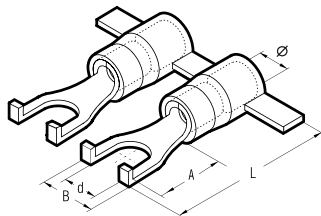

Cond. Size sqmm (AWG)	Ø Stud mm	Type	Dimensions mm					Quantity
			Ø	B	A	L	d	
1,5÷2,5 (16÷14)	4	CBP-U 4/3L*	4,9	6,5	9,5	14,5	4,3	1.750

hooked blade terminals

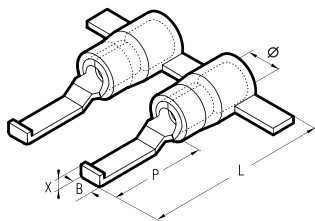

Cond. Size sqmm (AWG)	Type	Dimensions mm					Quantity
		Ø	B	P	L	X	
0,25÷1,5 (22÷16)	CRP-PPL30*	4,0	3,0	17,5	28,8	1,7	2.000
1,5÷2,5 (16÷14)	CBP-PPL30*	4,9	3,0	17,5	28,8	1,7	1.750

ring terminals

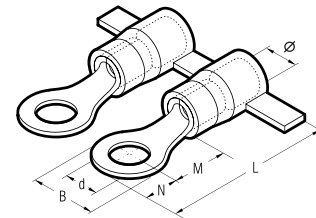

Cond. Size sqmm (AWG)	Ø Stud mm	Type	Dimensions mm					Quantity	
			Ø	B	M	N	L		d
0,25÷1,5 (22÷16)	3	CRP-M3	4,0	5,6	4,5	2,8	17,4	3,2	2.000
	3,5	CRP-M3.5*	4,0	5,6	4,5	2,8	17,4	3,7	2.000
	3,5	CRP-M3.5/1	4,0	6,2	7,1	3,1	20,2	3,7	2.000
	4	CRP-M4	4,0	7,0	6,5	3,5	20,1	4,3	2.000
	4	CRP-M4/3*	4,0	7,8	7,1	3,9	21,1	4,3	2.000
	5	CRP-M5	4,0	7,8	7,1	3,9	21,1	5,3	2.000
	6	CRP-M6	4,0	9,4	8,1	4,7	22,9	6,4	2.000
	6	CRP-M6/1*	4,0	12,0	10,3	6,0	26,4	6,4	2.000
1,5÷2,5 (16÷14)	7	CRP-M7	4,0	9,4	8,1	4,7	22,9	7,2	2.000
	8	CRP-M8	4,0	12,0	10,3	6,0	26,4	8,4	2.000
	3	CBP-M3	4,9	5,6	5,0	2,8	17,9	3,2	1.750
	3,5	CBP-M3.5	4,9	5,6	5,0	2,8	17,9	3,7	1.750
	3,5	CBP-M3.5/1*	4,9	6,2	6,5	3,1	19,6	3,7	1.750
	4	CBP-M4	4,9	8,0	6,5	4,0	20,6	4,3	1.750
	5	CBP-M5	4,9	8,0	7,5	4,0	21,6	5,3	1.750
	6	CBP-M6	4,9	9,4	8,6	4,7	23,4	6,4	1.750
4÷6 (12÷10)	6	CBP-M6/1*	4,9	12,0	10,3	6,0	26,4	6,4	1.750
	7	CBP-M7	4,9	10,0	7,8	5,0	22,9	7,2	1.750
	8	CBP-M8	4,9	12,0	10,3	6,0	26,4	8,4	1.750
	3	CGP-M3	6,6	8,0	8,1	4,0	26,2	3,2	1.250
	3,5	CGP-M3.5	6,6	8,0	8,1	4,0	26,2	3,7	1.250
	4	CGP-M4	6,6	9,0	8,1	4,5	26,7	4,3	1.250
	5	CGP-M5	6,6	9,0	8,1	4,5	26,7	5,3	1.250
	6	CGP-M6	6,6	11,0	11,1	5,5	30,7	6,4	1.250
	6	CGP-M6/1*	6,6	11,0	8,1	5,5	27,7	6,4	1.250
	7	CGP-M7	6,6	11,0	11,1	5,5	30,7	7,2	1.000
8	CGP-M8	6,6	13,6	12,1	6,8	33,0	8,4	1.250	
8	CGP-M8/1*	6,6	11,0	8,1	5,5	27,7	8,4	1.250	
10	CGP-M10	6,6	13,6	12,1	6,8	33,0	10,5	1.250	



Interchangeable application heads are available for crimping these terminals with the bench press ELB-3 (see page 146).

*Not UL approved *Made to order

RKY BKY GKY

REINFORCED PA 6.6 INSULATED TERMINALS

KY range - for Copper conductors



'KY' type terminals are designed to offer improved mechanical and electrical integrity under heavy-duty application.

This is achieved via a Copper sleeve located between the Copper barrel and Polyamide insulation of the terminal. Then, during crimping, the insulation of the conductor is integrated into the crimp due to the Copper sleeve being deformed around it to maintain the level of 'grip' required in applications subject to continuous mechanical vibrations (e.g: mobile plant, vehicles, moving components).

The operating temperature range is – 20 to + 115°C (Surge + 130°C).

Recommended crimping tools are shown on pages 120 to 143, 184, 245.

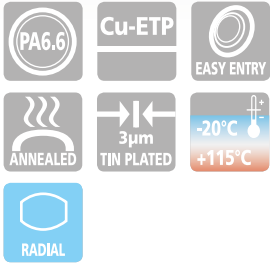

HF
HALOGEN
FREE

pin terminals

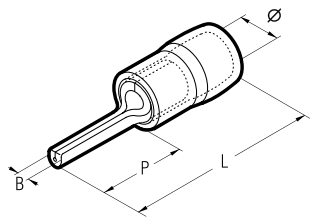

Conductor Size sqmm (AWG)	Type	Dimensions mm				Quantity Box/Bag
		Ø	B	P	L	
0,25÷1,5 (22÷16)	RKY-P8	4,5	1,9	9,0	19,8	3.000/100
	RKY-P10	4,5	1,9	10,0	20,8	3.500/100
	RKY-P12	4,5	1,9	12,0	22,8	3.000/100
1,5÷2,5 (16÷14)	BKY-P8	5,2	1,9	9,0	19,8	3.000/100
	BKY-P10	5,2	1,9	10,0	20,8	3.000/100
	BKY-P12	5,2	1,9	12,0	22,8	3.000/100
4÷6 (12÷10)	GKY-P14	7,0	2,8	14,0	27,0	1.000/100

blade terminals

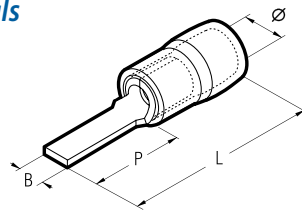

Conductor Size sqmm (AWG)	Type	Dimensions mm				Quantity Box/Bag
		Ø	B	P	L	
0,25÷1,5 (22÷16)	RKY-PP12	4,5	3,0	13,0	23,8	3.000/100
	RKY-PP12/19	4,5	2,0	18,0	28,8	3.000/100
	RKY-PP16/23	4,5	2,2	18,0	28,8	2.500/100
1,5÷2,5 (16÷14)	BKY-PP12	5,2	3,0	13,0	23,8	2.500/100
	BKY-PP12/25	5,2	2,4	13,0	23,8	2.000/100
	BKY-PP16/23	5,2	2,2	18,0	28,8	2.500/100
4÷6 (12÷10)	GKY-PP12	7,0	4,0	14,0	27,0	1.000/100
	GKY-PP17	7,0	2,0	18,0	31,0	1.000/100

hooked blade terminals

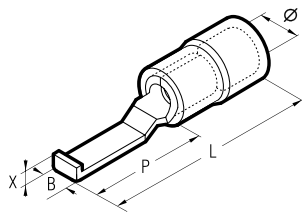

Conductor Size sqmm (AWG)	Type	Dimensions mm					Quantity Box/Bag
		Ø	B	P	L	X	
0,25÷1,5 (22÷16)	RKY-PPL30	4,5	3,0	16,8	28,2	2,1	3.000/100
	RKY-PPL46	4,5	4,6	16,8	28,2	2,1	3.000/100
1,5÷2,5 (16÷14)	BKY-PPL30	5,2	3,0	16,8	28,2	2,1	2.500/100
	BKY-PPL46	5,2	4,6	16,8	28,2	2,1	2.500/100
4÷6 (12÷10)	GKY-PPL46	7,0	4,6	17,2	30,2	2,4	1.000/100

Consult Cembre for a wider range of pin and blade dimensions.

ring terminals

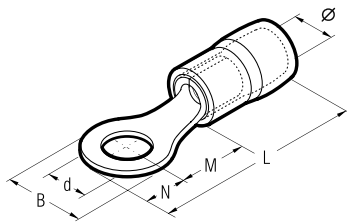

fork/spade terminals

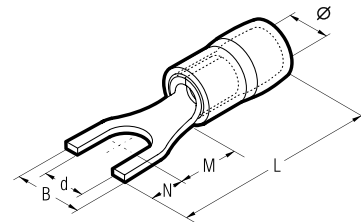

Cond. Size sqmm (AWG)	Ø Stud mm	Type	Dimensions mm						Quantity Box/Bag
			Ø	B	M	N	L	d	
0,25÷1,5 (22÷16)	3	RKY-M3	4,5	5,5	5,0	2,5	18,5	3,2	3.000/100
	3,5	RKY-M3.5	4,5	5,5	5,0	2,5	18,5	3,7	3.000/100
	3,5	RKY-M3.5/1	4,5	6,6	6,3	3,1	20,4	3,7	3.000/100
	4	RKY-M4	4,5	6,6	6,3	3,1	20,4	4,3	3.000/100
	5	RKY-M5	4,5	8,0	7,0	3,8	21,8	5,3	2.500/100
	6	RKY-M6/1	4,5	11,6	11,0	5,8	27,8	6,4	2.000/100
	8	RKY-M8	4,5	11,6	11,0	5,8	27,8	8,4	2.500/100
	10	RKY-M10	4,5	13,6	13,9	6,6	31,5	10,5	1.500/100
	12	RKY-M12	4,5	19,6	16,0	9,4	36,4	13,0	1.500/100
	3	BKY-M3	5,2	6,6	4,8	3,0	18,8	3,2	2.500/100
	3,5	BKY-M3.5	5,2	6,6	4,8	3,0	18,8	3,7	2.500/100
	1,5÷2,5 (16÷14)	3,5	BKY-M3.5/1	5,2	6,6	6,3	3,1	20,4	3,7
4		BKY-M4	5,2	8,5	7,8	4,0	22,8	4,3	2.500/100
5		BKY-M5	5,2	8,5	7,8	4,0	22,8	5,3	2.500/100
6		BKY-M6/1	5,2	12,0	11,0	5,8	27,8	6,4	2.000/100
8		BKY-M8	5,2	12,0	11,0	5,8	27,8	8,4	1.500/100
10		BKY-M10	5,2	13,6	13,9	6,6	31,5	10,5	1.500/100
4÷6 (12÷10)	12	BKY-M12	5,2	19,2	16,0	9,4	36,4	13,0	1.000/100
	3,5	GKY-M3.5	7,0	7,2	6,1	3,6	22,7	3,7	1.000/100
	4	GKY-M4	7,0	9,5	9,1	4,5	26,6	4,3	1.000/100
	5	GKY-M5	7,0	9,5	9,1	4,5	26,6	5,3	1.000/100
	6	GKY-M6	7,0	12,0	10,5	6,0	29,5	6,4	1.000/100
	8	GKY-M8	7,0	15,0	13,5	7,5	34,0	8,4	1.000/100
	10	GKY-M10	7,0	15,0	13,5	7,5	34,0	10,5	1.000/100
	12	GKY-M12	7,0	19,2	16,0	9,6	38,6	13,0	1.000/100
14	GKY-M14	7,0	32,0	25,2	16,0	54,2	15,0	500/100	
16	GKY-M16	7,0	32,0	25,2	16,0	54,2	17,0	500/100	

Cond. Size sqmm (AWG)	Ø Stud mm	Type	Dimensions mm						Quantity Box/Bag
			Ø	B	M	N	L	d	
0,25÷1,5 (22÷16)	3	RKY-U3	4,5	5,7	6,5	4,5	22,0	3,2	2.500/100
	3,5	RKY-U3.5	4,5	5,7	6,5	4,5	22,0	3,7	2.500/100
	4	RKY-U4	4,5	6,4	6,5	4,5	22,0	4,3	3.000/100
	5	RKY-U5	4,5	8,1	6,5	4,5	22,0	5,3	3.000/100
	6	RKY-U6	4,5	9,5	6,5	4,5	22,0	6,4	2.000/100
	6	RKY-U6/1	4,5	12,0	11,0	6,0	28,0	6,4	2.000/100
	3	BKY-U3	5,2	5,7	6,5	4,5	22,0	3,2	2.500/100
	3,5	BKY-U3.5	5,2	6,0	6,5	4,5	22,0	3,7	2.500/100
	4	BKY-U4	5,2	6,4	6,5	4,5	22,0	4,3	2.500/100
	5	BKY-U5	5,2	7,9	6,5	4,5	22,0	5,3	2.000/100
	6	BKY-U6	5,2	9,3	6,5	4,5	22,0	6,4	2.000/100
	6	BKY-U6/1	5,2	12,0	11,0	6,0	28,0	6,4	2.000/100
1,5÷2,5 (16÷14)	3,5	GKY-U3.5	7,0	7,2	7,5	3,9	24,4	3,7	1.000/100
	4	GKY-U4	7,0	7,2	7,5	3,9	24,4	4,3	1.000/100
	5	GKY-U5	7,0	9,0	7,0	5,5	25,5	5,3	1.000/100
	6	GKY-U6	7,0	12,0	12,0	6,5	31,5	6,4	1.000/100
	8	GKY-U8	7,0	14,0	10,5	7,0	30,5	8,4	1.000/100

Consult Cembre for a wider range of pin and blade dimensions.

RKF-F BKF-F GK-F

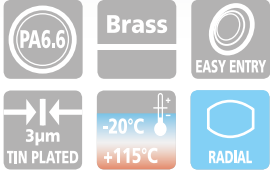

Recommended crimping tools are shown on pages 120 to 143, 184, 245.

female connectors, fully reinforced with Copper sleeve

PA6.6 insulated terminals

Conductor Size sqmm (AWG)	Type	Tab Size mm	Quantity Box/Bag
0,25÷1,5 (22÷16)	RKF-F305	2,8 x 0,5	3.000/100
	RKF-F308	2,8 x 0,8	3.000/100
	RKF-F405	4,8 x 0,5	2.500/100
	RKF-F408	4,8 x 0,8	2.500/100
1,5÷2,5 (16÷14)	RKF-F608	6,35 x 0,8	2.500/100
	BKF-F405	4,8 x 0,5	2.500/100
	BKF-F408	4,8 x 0,8	2.500/100
4÷6 (12÷10)	BKF-F608	6,35 x 0,8	2.000/100
	GK-F608	6,35 x 0,8	1.500/100

PA6.6 fully insulated terminals

Conductor Size sqmm (AWG)	Type	Tab Size mm	Quantity Box/Bag
0,25÷1,5 (22÷16)	RKF-F405P	4,8 x 0,5	1.500/100
	RKF-F408P	4,8 x 0,8	2.000/100
1,5÷2,5 (16÷14)	RKF-F608P	6,35 x 0,8	1.000/100
	BKF-F405P	4,8 x 0,5	1.500/100
4÷6 (12÷10)	BKF-F408P	4,8 x 0,8	2.000/100
	BKF-F608P	6,35 x 0,8	1.000/100
	GK-F608P	6,35 x 0,8	1.000/100

HF
HALOGEN FREE

RKF BKF GK

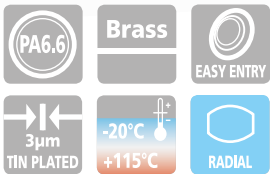

male connectors, fully reinforced with Copper sleeve - PA6.6 insulated terminals

Conductor Size sqmm (AWG)	Type	Tab Size mm	Quantity Box/Bag
0,25÷1,5 (22÷16)	RKF-M608	6,35 x 0,8	3.000/100
1,5÷2,5 (16÷14)	BKF-M608	6,35 x 0,8	2.500/100
4÷6 (12÷10)	GK-F608	6,35 x 0,8	1.000/100

male/female connectors, fully reinforced with Copper sleeve PA6.6 insulated terminals

Conductor Size sqmm (AWG)	Type	Tab Size mm	Quantity Box/Bag
0,25÷1,5 (22÷16)	RKF-FM608	6,35 x 0,8	1.500/100
1,5÷2,5 (16÷14)	BKF-FM608	6,35 x 0,8	1.500/100

Recommended crimping tools are shown on pages 120 to 143, 184, 245.

HF
HALOGEN FREE

bullet and socket connectors fully reinforced with Copper sleeve PA6.6 insulated terminals

Conductor Size sqmm (AWG)	Type	Ø mm	Quantity Box/Bag
0,25÷1,5 (22÷16)	RKF-BM4	4	2.500/100
	RKF-BF4	4	1.000/100
1,5÷2,5 (16÷14)	BKF-BM4	5	2.000/100
	BKF-BF4	5	800/100

RN-FA BN-FA



Recommended crimping tools are shown on pages 120 to 143, 184, 245.

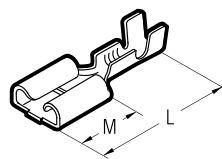

FEMALE CONNECTORS

for Copper conductors

Conductor Size sqmm (AWG)	Type	Tab Size mm	M mm	L mm	Quantity Box/Bag
0,5÷1 (20÷17)	RN-FA305	2,8 x 0,5	6,3	15,0	6.000/100
	RN-FA405	4,8 x 0,5	6,3	15,0	5.000/100
	RN-FA608	6,3 x 0,8	7,7	19,0	3.000/100
1÷2,5 (17÷14)	BN-FA608	6,3 x 0,8	7,7	19,0	2.000/100
	BN-FAB608*	6,3 x 0,8	7,7	15,5	2.000/100
	BN-FAR608**	6,3 x 0,8	7,7	19,0	3.000/100

*flag type **with retainer

MALE CONNECTORS

open barrel - for Copper conductors

Conductor Size sqmm (AWG)	Type	Tab Size mm	M mm	L mm	Quantity Box/Bag
0,5÷1 (20÷17)	RN-MA305	2,8 x 0,5	5,8	13,0	6.000/100
	RN-MA405	4,8 x 0,5	6,3	17,3	5.000/100
	RN-MA608	6,3 x 0,8	7,9	19,7	4.000/100
1÷2,5 (17÷14)	BN-MA608	6,3 x 0,8	7,9	20,0	4.000/100

Recommended crimping tools are shown on page 126.

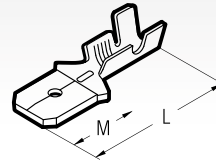

RN-MA BN-MA



MALE TABS

for board mounting - for Copper conductors

Type	Tab Size mm	Ø Stud mm	B mm	C mm	α	Quantity Box/Bag
MP608	6,3 x 0,8	4,0	8,0	8,5	0°	5.000/100
MP608/45	6,3 x 0,8	4,0	8,0	8,5	45°	6.000/100
MP608/90	6,3 x 0,8	4,0	8,0	8,5	90°	5.000/100
MP608D*	6,3 x 0,8	5,0	8,0	14,0	0°	5.000/100

*double tab

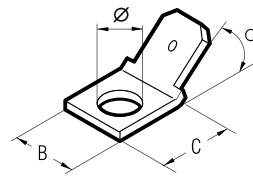

MP MPD



CONNECTOR SLEEVES

Type	Connector	B mm	M mm	L mm	Material	Quantity Box/Bag
CFA300	Female 2,8	5,5	7	18	Polyethylene	3.000/100
CFA400*	Female 4,8	7,5	9	20	Polyethylene	2.000/100
CFA600*	Female 6,3	9,0	11	24	Polyethylene	1.000/100
CFA2-600**	Female 6,3	9,0	9	22	Polyethylene	1.500/100
CFAR600	Female 6,3 with retainer	9,0	12	25	Polyamide 6.6	500/100
CFAB600	Female 6,3 flag	10,0	-	18	Polyamide 6.6	500/50
CMA600*	Male 6,3	12,0	11	22	Polyethylene	500/100

CFA CMA

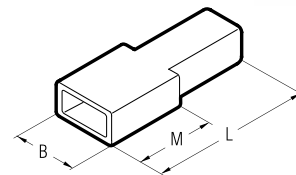

*For a single cable.
Colours available:
Transparent: no suffix
Red: add suffix R
Black: add suffix N

**For twin cables.
Colours available:
Transparent: no suffix
Red: add suffix R
Black: add suffix N
Green: add suffix V
Blue: add suffix B
Yellow: add suffix G

PKD

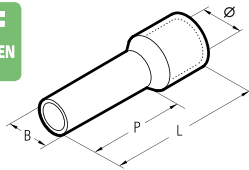

VALSTAR-ND2/PKD

- Comprising:
- a selection of end sleeves PKD conductor size 1-6 sqmm
 - tool ND2.

VALSTAR-ND2/PKE

- Comprising:
- a selection of end sleeves PKE conductor size 1-6 sqmm
 - tool ND2

VALSTAR-ND2/PKC

- Comprising:
- a selection of end sleeves PKC conductor size 1-6 sqmm
 - tool ND2

PA6 INSULATED END SLEEVES

for flexible Copper conductors

Conductor Size sqmm	Type	Dimensions mm				Insulation Colour	Quantity Box/Bag
		Ø	B	P	L		
0,3÷0,5	PKD506	2,6	1,4	6,0	12,0	○ white	10.000/500
	PKD508	2,6	1,4	8,0	14,0		10.000/500
	PKD510	2,6	1,4	10,0	16,0		10.000/500
0,75	PKD7506	2,8	1,6	6,0	12,0	● grey	10.000/500
	PKD7508	2,8	1,6	8,0	14,0		10.000/500
	PKD7510	2,8	1,6	10,0	16,0		10.000/500
1	PKD7512	2,8	1,6	12,0	18,0	● red	10.000/500
	PKD106	3,0	1,8	6,0	12,0		10.000/500
	PKD108	3,0	1,8	8,0	14,0		10.000/500
1,5	PKD110	3,0	1,8	10,0	16,0	● black	10.000/500
	PKD112	3,0	1,8	12,0	18,0		8.000/500
	PKD1508	3,5	2,1	8,0	14,0		5.000/500
2,5	PKD1510	3,5	2,1	10,0	16,0	● blue	5.000/500
	PKD1512	3,5	2,1	12,0	18,0		5.000/500
	PKD1518	3,5	2,1	18,0	24,0		5.000/500
4	PKD2508	4,2	2,6	8,0	14,0	● yellow	5.000/500
	PKD2512	4,2	2,6	12,0	18,0		4.000/500
	PKD2518	4,2	2,6	18,0	24,0		5.000/500
6	PKD410	4,8	3,3	10,0	18,0	● grey	3.000/200
	PKD412	4,8	3,3	12,0	20,0		3.000/200
	PKD418	4,8	3,3	18,0	26,0		3.000/200
10	PKD612	6,3	4,0	12,0	20,0	● red	1.500/100
	PKD618	6,3	4,0	18,0	26,0		2.000/100
	PKD1012	7,6	5,0	12,0	22,0		1.000/100
16	PKD1018	7,6	5,0	18,0	28,0	● blue	1.000/100
	PKD1612	8,8	6,4	12,0	24,0		800/100
	PKD1618	8,8	6,4	18,0	28,0		1.000/100
25	PKD25016	11,2	7,9	16,0	30,0	● yellow	500/50
	PKD25022	11,2	7,9	22,0	36,0		500/50
	PKD35016	12,7	8,9	16,0	30,0		400/50
35	PKD35025	12,7	8,9	25,0	39,0	● red	400/50
	PKD50020	15,0	11,0	20,0	36,0		200/50
	PKD50025	15,0	11,0	25,0	41,0		200/50

PKE

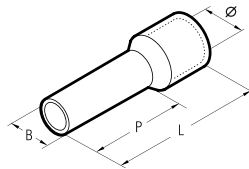

PA6 INSULATED END SLEEVES

for flexible Copper conductors

Conductor Size sqmm	Type	Dimensions mm				Insulation Colour	Quantity Box/Bag
		Ø	B	P	L		
0,1÷0,3	PKE308	1,9	1,1	8,0	12,0	● yellow	20.000/500
0,3÷0,5	PKE508*	2,6	1,4	8,0	14,0	○ white	10.000/500
0,75	PKE7508	2,8	1,6	8,0	14,0	● blue	10.000/500
1	PKE108*	3,0	1,8	8,0	14,0	● red	10.000/500
	PKE1508*	3,5	2,1	8,0	14,0		5.000/500
1,5	PKE1510*	3,5	2,1	10,0	16,0	● black	5.000/500
	PKE1518*	3,5	2,1	18,0	24,0		5.000/500
2,5	PKE2508	4,2	2,6	8,0	14,0	● grey	5.000/500
	PKE2512	4,2	2,6	12,0	18,0		4.000/500
	PKE2518	4,2	2,6	18,0	24,0		3.000/500
4	PKD410	4,8	3,3	10,0	18,0	● orange	3.000/200
	PKE412	4,8	3,3	12,0	20,0		3.000/200
	PKE418	4,8	3,3	18,0	26,0		3.000/200
6	PKE612	6,3	4,0	12,0	20,0	● green	1.500/100
	PKE618	6,3	4,0	18,0	26,0		1.500/100
10	PKE1012	7,6	5,0	12,0	22,0	● brown	1.000/100
	PKE1018	7,6	5,0	18,0	28,0		1.000/100
16	PKE1612	8,8	6,2	12,0	23,0	○ ivory	800/100
	PKE1618	8,8	6,2	18,0	29,0		1.000/100
25	PKE25016	11,2	7,9	16,0	30,0	● black	500/50
	PKE25022	11,2	7,9	22,0	36,0		500/50

*to DIN standard 46 228/4

PA6 INSULATED END SLEEVES

for flexible Copper conductors

PKC

Conductor Size sqmm	Type	Dimensions mm				Insulation Colour	Quantity Box/Bag
		Ø	B	P	L		
0,1÷0,3	PKC306	1,9	1,1	6,0	10,0	light blue	20.000/500
	PKC308	1,9	1,1	8,0	12,0	blue	20.000/500
0,3÷0,5	PKC508	2,6	1,4	8,0	14,0	orange	10.000/500
	PKC510	2,6	1,4	10,0	16,0	orange	10.000/500
0,75	PKC7508	2,8	1,6	8,0	14,0	white	10.000/500
	PKC7512	2,8	1,6	12,0	18,0	white	10.000/500
1	PKC108	3,0	1,8	8,0	14,0	yellow	10.000/500
	PKC112	3,0	1,8	12,0	18,0	yellow	10.000/500
1,5	PKC1508	3,5	2,1	8,0	14,0	red	5.000/500
	PKC1510	3,5	2,1	10,0	16,0	red	5.000/500
	PKC1518	3,5	2,1	18,0	24,0	red	5.000/500
2,5	PKC2508*	4,2	2,6	8,0	14,0	blue	5.000/500
	PKC2512*	4,2	2,6	12,0	18,0	blue	5.000/500
	PKC2518*	4,2	2,6	18,0	24,0	blue	5.000/500
4	PKC410*	4,8	3,3	10,0	18,0	grey	3.000/200
	PKC412*	4,8	3,3	12,0	20,0	grey	3.000/200
	PKC418*	4,8	3,3	18,0	26,0	grey	3.000/200
6	PKC612	6,3	4,0	12,0	20,0	black	1.500/100
	PKC618	6,3	4,0	18,0	26,0	black	2.000/100
10	PKC1012	7,6	5,0	12,0	22,0	ivory	1.000/100
	PKC1018	7,6	5,0	18,0	28,0	ivory	1.000/100
16	PKC1612	8,8	6,2	12,0	23,0	green	800/100
	PKC1618	8,8	6,2	18,0	29,0	green	1.000/100
25	PKC25016	11,2	7,9	16,0	30,0	brown	500/50
	PKC25022	11,2	7,9	22,0	36,0	brown	500/50
35	PKC35016	12,7	8,9	16,0	30,0	beige	400/50
	PKC35025	12,7	8,9	25,0	39,0	beige	300/50
50	PKC50020	15,0	11,0	20,0	36,0	olive	200/50
	PKC50025	15,0	11,0	25,0	41,0	olive	200/50
70	PKC70022	16,0	14,3	22,0	38,0	yellow	100/25
95	PKC95025	18,0	15,7	25,0	44,0	red	100/25
120	PKC120027	21,0	17,5	27,0	48,0	blue	100/25

HF HALOGEN FREE

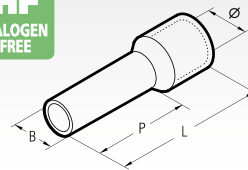

*to DIN standard 46 228/4

"TWIN" PA6 INSULATED END SLEEVES

for fine stranded conductors

PKT

HF HALOGEN FREE
UL US
File no. E129401

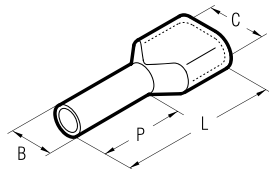

Conductor Size sqmm	Type	Dimensions mm				Insulation Colour	ND1,ND2,ND3, ND4 and HNKE 50 Compression Aperture	Quantity Box/Bag
		C	B	P	L			
2 x 0,5	PKT508	4,7x2,6	1,8	8,0	14,0	white	1	5.000/500
	PKT510*	4,7x2,6	1,8	10,0	18,0	white	1	5.000/500
2 x 0,75	PKT7508	5,0x2,8	2,1	8,0	15,0	grey	1,5	2.500/100
	PKT7510	5,0x2,8	2,1	10,0	17,0	grey	1,5	2.500/100
2 x 1	PKT108	5,4x3,4	2,4	8,0	16,0	red	2,5	2.500/100
	PKT110	5,4x3,4	2,4	10,0	18,0	red	2,5	2.500/100
2 x 1,5	PKT1508	6,6x3,6	2,6	8,0	16,0	black	2,5	2.500/100
	PKT1512	6,6x3,6	2,6	12,0	20,0	black	2,5	2.500/100
2 x 2,5	PKT2510	7,8x4,2	3,2	10,0	20,0	blue	4	2.000/100
	PKT2512	7,8x4,2	3,2	12,0	22,0	blue	4	1.500/100
2 x 4	PKT412	8,8x4,9	4,2	12,0	23,0	grey	6	1.000/100
2 x 6	PKT614	10,0x6,9	5,3	14,0	26,0	yellow	10	800/100
2 x 10	PKT1014*	13,3x7,5	6,2	12,0	24,0	red	16	500/50
2 x 16	PKT1614	18,6x9,6	8,9	14,0	30,0	blue	35	300/50



Type PKT range of end sleeves is manufactured from Tin plated electrolytic Copper.

Designed to accommodate two cables terminating in the same sleeve.

The operating temperature range is -20 to +115°C (Surge +130°C).

Recommended crimping tools are shown on pages 120 to 145, 151-152, 184, 186, 188, 245.

*Not UL approved

for flexible Copper conductors

HF
HALOGEN
FREE



Conductor Size sqmm	Type	Dimensions mm				Insulation Colour	Quantity Box/Bag
		Ø	B	P	L		
0,3±0,5	CPKD508	2,6	1,3	8,0	14,0	○ white	5.000
0,75	CPKD7508	2,8	1,5	8,0	14,0	● grey	5.000
1	CPKD108	3,0	1,7	8,0	14,0	● red	5.000
1,5	CPKD1508	3,5	2,0	8,0	14,0	● black	5.000
2,5	CPKD2508	4,2	2,5	8,0	14,0	● blue	3.000

Conforms to DIN standard 46228/4.



Interchangeable application heads are available for crimping these terminals with the bench press ELB-3 (see page 146).

UNINSULATED END SLEEVES

for flexible Copper conductors

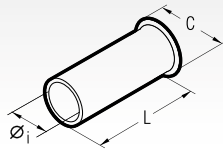

KE

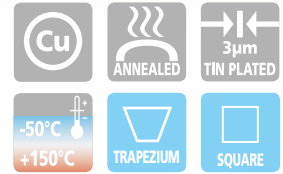

Conductor Size sqmm	Type	Dimensions mm			Quantity Box/Bag
		Ø	L	C	
0,5	KE506ST*	1,0	6,0	1,9	50.000/500
	KE508ST	1,0	8,0	1,9	50.000/500
0,75	KE7506ST*	1,2	6,0	2,2	40.000/500
	KE7508ST	1,2	8,0	2,2	40.000/500
1	KE106ST*	1,4	6,0	2,4	25.000/500
	KE110ST*	1,4	10,0	2,4	25.000/500
1,5	KE1508ST	1,7	8,0	2,8	25.000/500
	KE1510ST*	1,7	10,0	2,8	25.000/500
2,5	KE2508ST	2,2	8,0	3,4	20.000/500
	KE2510ST*	2,2	10,0	3,4	15.000/500
4	KE410ST	2,8	10,0	4,0	12.500/500
	KE412ST*	2,8	12,0	4,0	10.000/500
6	KE610ST*	3,5	10,0	4,7	10.000/500
	KE612ST*	3,5	12,0	4,7	7.500/500
	KE616ST*	3,5	15,0	4,7	5.000/500
10	KE1016ST*	4,5	15,0	5,8	4.000/250
16	KE1616ST*	5,8	15,0	7,5	3.000/250
25	KE25015ST	7,3	15,0	9,5	1.500/100
	KE25018ST*	7,3	18,0	9,5	1.500/100
35	KE35012ST	8,3	12,0	10,5	1.500/100
	KE35015ST	8,3	16,0	10,5	1.500/100
	KE35018ST*	8,3	18,0	10,5	1.000/100

*to DIN standard 46 228/1

KE series end sleeves are manufactured from Tin plated electrolytic Copper with a purity greater than 99.9%.

Designed and developed for use with flexible cables.

Recommended crimping tools are shown on pages 120 to 145, 151-152, 184, 186, 188, 245.

S range - brazed seam - for Copper conductors



S range terminals are manufactured from electrolytic Copper strip with a purity greater than 99.9% and Tin plated.

The seam is brazed to provide uniform mechanical strength. The terminal barrel is rifled to enhance electrical contact and to im-

prove mechanical strength. Recommended crimping tools are shown on pages 120 to 143, 184.

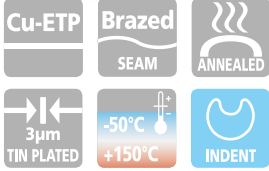

pin terminals

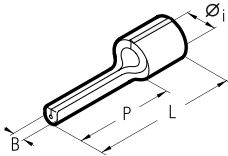

Conductor Size sqmm (AWG)	Type	Dimensions mm				Quantity Box/Bag
		Øi	B	P	L	
0,25÷1,5 [22÷16]	S1.5-P8	1,8	1,6	8,0	12,0	8.000/100
	S1.5-P10	1,8	1,6	10,0	14,0	8.000/100
	S1.5-P12	1,8	1,6	12,0	16,2	8.000/100
1,5÷2,5 [16÷14]	S2.5-P8	2,4	1,7	8,0	12,0	7.000/100
	S2.5-P10	2,4	1,8	10,0	14,0	7.000/100
	S2.5-P12	2,4	1,8	12,0	16,0	7.000/100
4÷6 [12÷10]	S6-P10	3,6	2,2	10,0	16,8	4.000/100
	S6-P12	3,6	2,2	12,0	19,0	4.000/100
	S6-P14	3,6	2,2	14,0	21,0	3.500/100

blade terminals

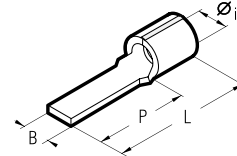

Conductor Size sqmm (AWG)	Type	Dimensions mm				Quantity Box/Bag
		Øi	B	P	L	
0,25÷1,5 [22÷16]	S1.5-PP12	1,8	3,0	12,8	17,0	8.000/100
	S1.5-PP12/1*	1,8	3,0	11,3	15,5	8.000/100
	S1.5-PP12/19	1,8	1,9	13,2	17,4	8.000/100
	S1.5-PP14	1,8	3,0	14,8	19,0	8.000/100
1,5÷2,5 [16÷14]	S2.5-PP12	2,4	3,5	12,8	17,0	7.000/100
	S2.5-PP12/25	2,4	2,5	13,3	17,5	7.000/100
	S2.5-PP16/25	2,4	2,5	17,2	21,4	7.000/100
4÷6 [12÷10]	S6-PP12	3,6	4,0	13,3	19,7	4.000/100
	S6-PP17	3,6	2,9	19,1	25,5	4.000/100

*Made to order

ring terminals

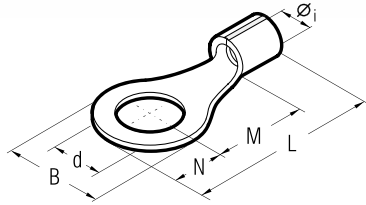

fork/spade terminals

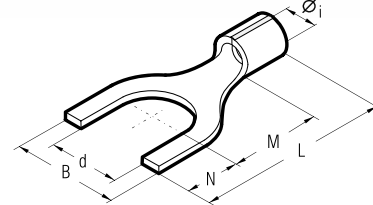

Conductor Size sqmm (AWG)	Ø Stud mm	Type	Dimensions mm						Quantity Box/Bag
			Øi	B	M	N	L	d	
0,25÷1,5 [22÷16]	2	S1.5-M2*	1,8	5,6	4,5	2,8	11,5	2,2	7.000/100
	3	S1.5-M3	1,8	5,6	4,5	2,8	11,5	3,2	7.000/100
	3,5	S1.5-M3.5	1,8	5,6	4,5	2,8	11,5	3,7	7.000/100
	3,5	S1.5-M3.5/1*	1,8	6,2	7,1	3,1	14,4	3,7	7.000/100
	4	S1.5-M4	1,8	7,0	6,5	3,5	14,2	4,3	7.000/100
	4	S1.5-M4/3*	1,8	7,8	7,1	3,9	15,2	4,3	7.000/100
	5	S1.5-M5	1,8	7,8	7,1	3,9	15,2	5,3	7.000/100
	6	S1.5-M6	1,8	9,4	8,1	4,7	17,0	6,4	6.000/100
	6	S1.5-M6/1	1,8	12,0	10,3	6,0	20,5	6,4	5.000/100
	7	S1.5-M7	1,8	9,4	8,1	4,7	17,0	7,2	6.000/100
	8	S1.5-M8	1,8	12,0	10,3	6,0	20,5	8,4	4.000/100
	10	S1.5-M10	1,8	15,5	13,0	7,7	25,0	10,5	3.000/100
12	S1.5-M12	1,8	18,0	15,5	9,0	28,7	13,0	2.000/100	
1,5÷2,5 [16÷14]	3	S2.5-M3	2,4	5,6	5,0	2,8	12,0	3,2	6.000/100
	3,5	S2.5-M3.5	2,4	5,6	5,0	2,8	12,0	3,7	6.000/100
	3,5	S2.5-M3.5/1*	2,4	6,2	6,5	3,1	13,8	3,7	5.000/100
	4	S2.5-M4	2,4	8,0	6,5	4,0	14,7	4,3	5.000/100
	5	S2.5-M5	2,4	8,0	7,5	4,0	15,7	5,3	5.000/100
	6	S2.5-M6	2,4	9,4	8,6	4,7	17,5	6,4	5.000/100
	6	S2.5-M6/1	2,4	12,0	10,3	6,0	20,5	6,4	5.000/100
	7	S2.5-M7	2,4	10,0	7,8	5,0	17,0	7,2	5.000/100
	8	S2.5-M8	2,4	12,0	10,3	6,0	20,5	8,4	4.000/100
	10	S2.5-M10	2,4	15,5	13,0	7,7	25,0	10,5	2.500/100
	12	S2.5-M12	2,4	18,0	15,5	9,0	28,7	13,0	2.000/100
	4÷6 [12÷10]	3	S6-M3	3,6	8,0	8,1	4,0	18,5	3,2
3,5		S6-M3.5	3,6	8,0	8,1	4,0	18,5	3,7	3.000/100
4		S6-M4	3,6	9,0	8,1	4,5	19,0	4,3	3.000/100
5		S6-M5	3,6	9,0	8,1	4,5	19,0	5,3	2.500/100
6		S6-M6	3,6	11,0	11,1	5,5	23,0	6,4	2.500/100
6		S6-M6/1*	3,6	11,0	8,1	5,5	20,0	6,4	2.500/100
7		S6-M7	3,6	11,0	11,1	5,5	23,0	7,2	2.500/100
8		S6-M8	3,6	13,6	12,1	6,8	25,3	8,4	2.000/100
8		S6-M8/1*	3,6	11,0	8,1	5,5	20,0	8,4	2.500/100
10		S6-M10	3,6	13,6	12,1	6,8	25,3	10,5	2.000/100
10		S6-M10/1	3,6	15,5	13,8	7,7	28,0	10,5	2.000/100
12		S6-M12	3,6	19,0	15,1	9,5	31,0	13,0	1.000/100
14	S6-M14	3,6	21,0	16,1	10,5	33,0	15,0	1.000/100	
16	S6-M16	3,6	24,0	17,1	12,0	35,5	17,0	1.000/100	
10 (8)	4	S10-M4	4,8	11,5	9,0	5,8	23,8	4,3	2.000/100
	5	S10-M5	4,8	11,5	9,0	5,8	23,8	5,3	2.000/100
	6	S10-M6	4,8	11,5	9,0	5,8	23,8	6,4	2.000/100
	7	S10-M7	4,8	11,5	9,0	5,8	23,8	7,2	1.500/100

Conductor Size sqmm (AWG)	Ø Stud mm	Type	Dimensions mm						Quantity Box/Bag
			Øi	B	M	N	L	d	
0,25÷1,5 [22÷16]	3	S1.5-U3	1,8	5,5	5,5	4,0	13,7	3,2	7.000/100
	3,5	S1.5-U3.5	1,8	6,0	6,5	3,8	14,5	3,7	7.000/100
	3,5	S1.5-U3.5/2*	1,8	6,4	6,5	3,8	14,5	3,7	7.000/100
	4	S1.5-U4	1,8	6,5	7,5	3,7	15,4	4,3	7.000/100
	4	S1.5-U4/1*	1,8	8,5	7,5	3,7	15,4	4,3	7.000/100
	4	S1.5-U4/2	1,8	7,5	7,5	3,7	15,4	4,3	7.000/100
	5	S1.5-U5	1,8	8,5	7,5	3,7	15,4	5,3	7.000/100
	5	S1.5-U5/1	1,8	9,4	7,5	3,7	15,4	5,3	7.000/100
	6	S1.5-U6	1,8	9,4	8,1	4,7	17,0	6,4	6.000/100
	6	S1.5-U6/1*	1,8	12,0	9,2	7,1	20,5	6,4	6.000/100
	8	S1.5-U8	1,8	14,0	10,0	6,3	20,5	8,4	3.000/100
	10	S1.5-U10	1,8	17,5	13,0	7,7	25,0	10,5	2.500/100
12	S1.5-U12	1,8	20,0	15,5	9,0	28,7	13,0	2.000/100	
1,5÷2,5 [16÷14]	3	S2.5-U3	2,4	5,5	5,5	4,0	13,7	3,2	6.000/100
	3,5	S2.5-U3.5	2,4	6,4	6,5	3,8	14,5	3,7	6.000/100
	3,5	S2.5-U3.5/1*	2,4	7,2	6,5	3,8	14,5	3,7	6.000/100
	4	S2.5-U4	2,4	6,5	7,5	3,7	15,4	4,3	5.000/100
	4	S2.5-U4/1*	2,4	8,5	7,5	3,7	15,4	4,3	6.000/100
	4	S2.5-U4/2*	2,4	7,5	7,5	3,7	15,4	4,3	6.000/100
	5	S2.5-U5	2,4	8,5	7,5	3,7	15,4	5,3	6.000/100
	6	S2.5-U6	2,4	9,4	8,1	4,7	17,0	6,4	5.000/100
	6	S2.5-U6/1*	2,4	12,0	9,2	7,1	20,5	6,4	4.000/100
	8	S2.5-U8	2,4	14,0	10,0	6,3	20,5	8,4	2.500/100
	10	S2.5-U10	2,4	17,5	13,0	7,7	25,0	10,5	2.000/100
	12	S2.5-U12	2,4	20,0	15,5	9,0	28,7	13,0	2.000/100
4÷6 [12÷10]	3,5	S6-U3.5	3,6	7,5	8,5	3,9	18,8	3,7	3.000/100
	4	S6-U4	3,6	7,5	8,0	4,4	18,8	4,3	3.000/100
	5	S6-U5	3,6	9,5	8,0	4,4	18,8	5,3	2.500/100
	6	S6-U6	3,6	10,0	11,0	5,5	22,9	6,4	2.500/100
	8	S6-U8	3,6	13,5	12,0	8,0	26,4	8,4	2.000/100
	10	S6-U10	3,6	15,5	13,0	8,0	27,4	10,5	2.000/100
	10	S6-U10/1*	3,6	17,5	13,8	7,7	28,0	10,5	2.000/100
	12	S6-U12	3,6	21,0	15,1	9,5	31,0	13,0	1.000/100
	14	S6-U14	3,6	23,0	16,1	10,5	33,0	15,0	1.000/100
	16	S6-U16*	3,6	26,0	17,1	11,5	35,0	17,0	1.000/100

*Made to order

RN, BN, GN range - unbrazed - for Copper conductors



RN, BN, GN range terminals are manufactured from electrolytic Copper strip with a purity greater than 99.9% and Tin plated.

The seam is unbrazed. The terminal barrel is rifled to enhance electrical contact and to improve mechanical strength.

Recommended crimping tools are shown on pages 120 to 143, 184.

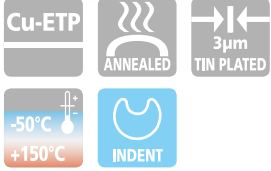

pin terminals

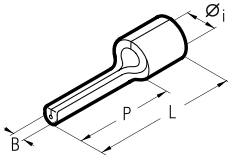

Conductor Size sqmm (AWG)	Type	Dimensions mm				Quantity Box/Bag
		Øi	B	P	L	
0,25÷1,5 [22÷16]	RN-P8	1,8	1,6	8,0	12,0	8.000/100
	RN-P10	1,8	1,6	10,0	14,0	8.000/100
	RN-P12	1,8	1,6	12,0	16,2	8.000/100
1,5÷2,5 [16÷14]	BN-P8	2,4	1,7	8,0	12,0	7.000/100
	BN-P10	2,4	1,8	10,0	14,0	7.000/100
	BN-P12	2,4	1,8	12,0	16,0	7.000/100
4÷6 [12÷10]	GN-P10	3,6	2,2	10,0	16,8	4.000/100
	GN-P12	3,6	2,2	12,0	19,0	4.000/100
	GN-P14	3,6	2,2	14,0	21,0	3.500/100

blade terminals

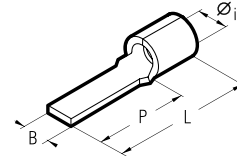

Conductor Size sqmm (AWG)	Type	Dimensions mm				Quantity Box/Bag
		Øi	B	P	L	
0,25÷1,5 [22÷16]	RN-PP12	1,8	3,0	12,8	17,0	8.000/100
	RN-PP12/1	1,8	3,0	11,3	15,5	8.000/100
	RN-PP12/19	1,8	1,9	13,2	17,4	8.000/100
	RN-PP14	1,8	3,0	14,8	19,0	8.000/100
	RN-PP16/23	1,8	2,3	17,2	21,4	8.000/100
1,5÷2,5 [16÷14]	BN-PP12	2,4	3,5	12,8	17,0	7.000/100
	BN-PP12/25	2,4	2,5	13,3	17,5	7.000/100
	BN-PP16/25	2,4	2,5	17,2	21,4	7.000/100
4÷6 [12÷10]	GN-PP12	3,6	4,0	13,3	19,7	4.000/100
	GN-PP17	3,6	2,9	19,1	25,5	4.000/100

ring terminals

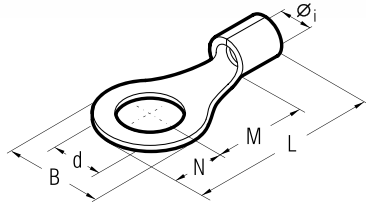

Conductor Size sqmm (AWG)	Ø Stud mm	Type	Dimensions mm					Quantity Box/Bag	
			Øi	B	M	N	L		d
0,25÷1,5 (22÷16)	2	RN-M2*	1,8	5,6	4,5	2,8	11,5	2,2	7.000/100
	3	RN-M3	1,8	5,6	4,5	2,8	11,5	3,2	7.000/100
	3,5	RN-M3.5	1,8	5,6	4,5	2,8	11,5	3,7	7.000/100
	3,5	RN-M3.5/1	1,8	6,2	7,1	3,1	14,4	3,7	7.000/100
	4	RN-M4	1,8	7,0	6,5	3,5	14,2	4,3	7.000/100
	4	RN-M4/3	1,8	7,8	7,1	3,9	15,2	4,3	7.000/100
	5	RN-M5	1,8	7,8	7,1	3,9	15,2	5,3	7.000/100
	6	RN-M6	1,8	9,4	8,1	4,7	17,0	6,4	6.000/100
	6	RN-M6/1	1,8	12,0	10,3	6,0	20,5	6,4	4.000/100
	7	RN-M7	1,8	9,4	8,1	4,7	17,0	7,2	6.000/100
	8	RN-M8	1,8	12,0	10,3	6,0	20,5	8,4	4.000/100
	10	RN-M10	1,8	15,5	13,0	7,7	25,0	10,5	3.000/100
12	RN-M12	1,8	18,0	15,5	9,0	28,7	13,0	2.000/100	
1,5÷2,5 (16÷14)	2	BN-M2*	2,4	5,6	5,0	2,8	12,0	2,2	6.000/100
	3	BN-M3	2,4	5,6	5,0	2,8	12,0	3,2	6.000/100
	3,5	BN-M3.5	2,4	5,6	5,0	2,8	12,0	3,7	6.000/100
	3,5	BN-M3.5/1	2,4	6,2	6,5	3,1	13,8	3,7	6.000/100
	4	BN-M4	2,4	8,0	6,5	4,0	14,7	4,3	5.000/100
	5	BN-M5	2,4	8,0	7,5	4,0	15,7	5,3	5.000/100
	6	BN-M6	2,4	9,4	8,6	4,7	17,5	6,4	5.000/100
	6	BN-M6/1	2,4	12,0	10,3	6,0	20,5	6,4	5.000/100
	7	BN-M7	2,4	10,0	7,8	5,0	17,0	7,2	5.000/100
	8	BN-M8	2,4	12,0	10,3	6,0	20,5	8,4	4.000/100
	10	BN-M10	2,4	15,5	13,0	7,7	25,0	10,5	2.500/100
	12	BN-M12	2,4	18,0	15,5	9,0	28,7	13,0	2.000/100
4÷6 (12÷10)	3	GN-M3	3,6	8,0	8,1	4,0	18,5	3,2	3.000/100
	3,5	GN-M3.5	3,6	8,0	8,1	4,0	18,5	3,7	3.000/100
	4	GN-M4	3,6	9,0	8,1	4,5	19,0	4,3	3.000/100
	5	GN-M5	3,6	9,0	8,1	4,5	19,0	5,3	2.500/100
	6	GN-M6	3,6	11,0	11,1	5,5	23,0	6,4	2.500/100
	6	GN-M6/1	3,6	11,0	8,1	5,5	20,0	6,4	2.500/100
	7	GN-M7	3,6	11,0	11,1	5,5	23,0	7,2	2.500/100
	8	GN-M8	3,6	13,6	12,1	6,8	25,3	8,4	2.000/100
	8	GN-M8/1*	3,6	11,0	8,1	5,5	20,0	8,4	2.500/100
	10	GN-M10	3,6	13,6	12,1	6,8	25,3	10,5	2.000/100
	10	GN-M10/1	3,6	15,5	13,8	7,7	28,0	10,5	2.000/100
	12	GN-M12	3,6	19,0	15,1	9,5	31,0	13,0	1.000/100
14	GN-M14	3,6	21,0	16,1	10,5	33,0	15,0	1.000/100	
16	GN-M16	3,6	24,0	17,1	12,0	35,5	17,0	1.000/100	

fork/spade terminals

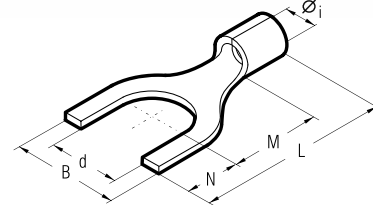

Conductor Size sqmm (AWG)	Ø Stud mm	Type	Dimensions mm					Quantity Box/Bag	
			Øi	B	M	N	L		d
0,25÷1,5 (22÷16)	3	RN-U3	1,8	5,5	5,5	4,0	13,7	3,2	7.000/100
	3,5	RN-U3.5	1,8	6,0	6,5	3,8	14,5	3,7	7.000/100
	3,5	RN-U3.5/2	1,8	6,4	6,5	3,8	14,5	3,7	7.000/100
	4	RN-U4	1,8	6,5	7,5	3,7	15,4	4,3	7.000/100
	4	RN-U4/1	1,8	8,5	7,5	3,7	15,4	4,3	7.000/100
	4	RN-U4/2	1,8	7,5	7,5	3,7	15,4	4,3	7.000/100
	5	RN-U5	1,8	8,5	7,5	3,7	15,4	5,3	5.000/100
	5	RN-U5/1*	1,8	9,4	7,5	3,7	15,4	5,3	5.000/100
	6	RN-U6	1,8	9,4	8,1	4,7	17,0	6,4	6.000/100
	6	RN-U6/1	1,8	12,0	9,2	7,1	20,5	6,4	3.000/100
	8	RN-U8	1,8	14,0	10,0	6,3	20,5	8,4	2.500/100
	10	RN-U10	1,8	17,5	13,0	7,7	25,0	10,5	2.000/100
12	RN-U12	1,8	20,0	15,5	9,0	28,7	13,0	2.000/100	
1,5÷2,5 (16÷14)	3	BN-U3	2,4	5,5	5,5	4,0	13,7	3,2	6.000/100
	3,5	BN-U3.5	2,4	6,4	6,5	3,8	14,5	3,7	6.000/100
	3,5	BN-U3.5/1*	2,4	7,2	6,5	3,8	14,5	3,7	6.000/100
	4	BN-U4	2,4	6,5	7,5	3,7	15,4	4,3	6.000/100
	4	BN-U4/1	2,4	8,5	7,5	3,7	15,4	4,3	6.000/100
	4	BN-U4/2	2,4	7,5	7,5	3,7	15,4	4,3	6.000/100
	5	BN-U5	2,4	8,5	7,5	3,7	15,4	5,3	5.000/100
	6	BN-U6	2,4	9,4	8,1	4,7	17,0	6,4	5.000/100
	6	BN-U6/1	2,4	12,0	9,2	7,1	20,5	6,4	4.000/100
	8	BN-U8	2,4	14,0	10,0	6,3	20,5	8,4	4.000/100
	10	BN-U10	2,4	17,5	13,0	7,7	25,0	10,5	2.000/100
	12	BN-U12	2,4	20,0	15,5	9,0	28,7	13,0	2.000/100
4÷6 (12÷10)	3,5	GN-U3.5	3,6	7,5	8,5	3,9	18,8	3,7	3.000/100
	4	GN-U4	3,6	7,5	8,0	4,4	18,8	4,3	3.000/100
	5	GN-U5	3,6	9,5	8,0	4,4	18,8	5,3	2.500/100
	6	GN-U6	3,6	10,0	11,0	5,5	22,9	6,4	2.500/100
	8	GN-U8	3,6	13,5	12,0	8,0	26,4	8,4	2.000/100
	10	GN-U10	3,6	15,5	13,0	8,0	27,4	10,5	2.000/100
	10	GN-U10/1	3,6	17,5	13,8	7,7	28,0	10,5	2.000/100
	12	GN-U12	3,6	21,0	15,1	9,5	31,0	13,0	1.000/100
	14	GN-U14	3,6	23,0	16,1	10,5	33,0	15,0	1.000/100
	16	GN-U16	3,6	26,0	17,1	11,5	35,0	17,0	1.000/100

*Made to order

Q

CRIMPING CONNECTORS ACCORDING TO DIN 46234

for Copper conductors

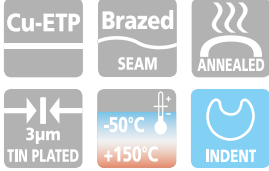
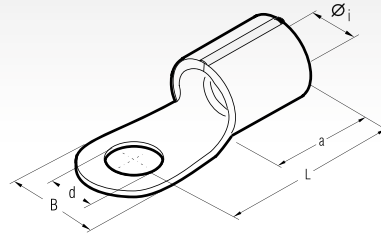

Q type connectors are manufactured from electrolytic Copper strip with a purity greater than 99.9%, annealed and surface protected by tin plating; dimensions are compliant with DIN 46234; the sleeve is brazed with a silver-Copper alloy. Details of the conductor csa and stud diameter are engraved on the palm. Details of the appropriate crimping tools and dies are shown on page 256.

Consult us for special requirements.

Conductor Size sqmm	Ø Stud mm	Type	Dimensions mm					Quantity Box/Bag	Mechanical Tools	Hydraulic Tools				
			Øi	d	L	B	a			HT120 and tools and heads with 130 kN crimping force				
6÷10	4	Q10-4	4,5	4,3	16,0	10,0	8,0	1.500/100	HN5	HT51	RH50	RH61	RH81	RHU81
	5	Q10-5	4,5	5,3	16,0	10,0	8,0	1.500/100						
	6	Q10-6	4,5	6,5	17,0	11,0	8,0	1.000/100						
	8	Q10-8	4,5	8,4	20,0	14,0	8,0	1.000/100						
	10	Q10-10	4,5	10,5	21,0	18,0	8,0	1.000/100						
10÷16	12	Q10-12	4,5	13,0	22,0	22,0	8,0	500/100						
	5	Q16-5	5,8	5,3	20,0	11,0	10,0	1.000/100						
	6	Q16-6	5,8	6,5	20,0	11,0	10,0	1.000/100						
	8	Q16-8	5,8	8,4	22,0	14,0	10,0	500/100						
16÷25	10	Q16-10	5,8	10,5	24,0	18,0	10,0	500/100						
	12	Q16-12	5,8	13,0	26,0	22,0	10,0	500/100						
	5	Q25-5	7,5	5,3	25,0	12,0	11,0	500/100						
	6	Q25-6	7,5	6,5	25,0	12,0	11,0	500/100						
	8	Q25-8	7,5	8,4	25,0	16,0	11,0	500/100						
25÷35	10	Q25-10	7,5	10,5	26,0	18,0	11,0	500/100						
	12	Q25-12	7,5	13,0	31,0	22,0	11,0	500/100						
	16	Q25-16	7,5	17,0	35,0	28,0	11,0	200/100						
	6	Q35-6	9,0	6,5	26,0	15,0	12,0	400/100						
35÷50	8	Q35-8	9,0	8,4	26,0	16,0	12,0	400/100						
	10	Q35-10	9,0	10,5	27,0	18,0	12,0	300/100						
	12	Q35-12	9,0	13,0	31,0	22,0	12,0	250/50						
	16	Q35-16	9,0	17,0	36,0	28,0	12,0	200/50						
50÷70	6	Q50-6	11,0	6,5	34,0	18,0	16,0	200/50						
	8	Q50-8	11,0	8,4	34,0	18,0	16,0	200/50						
	10	Q50-10	11,0	10,5	34,0	18,0	16,0	200/50						
	12	Q50-12	11,0	13,0	36,0	22,0	16,0	200/50						
70÷95	16	Q50-16	11,0	17,0	40,0	28,0	16,0	200/50						
	6	Q70-6	13,0	6,5	38,0	22,0	18,0	100/50						
	8	Q70-8	13,0	8,4	38,0	22,0	18,0	100/50						
	10	Q70-10	13,0	10,5	38,0	22,0	18,0	100/50						
70÷95	12	Q70-12	13,0	13,0	38,0	22,0	18,0	100/50						
	16	Q70-16	13,0	17,0	42,0	28,0	18,0	100/50						
	8	Q95-8	15,0	8,4	42,0	24,0	20,0	100/25						
	10	Q95-10	15,0	10,5	42,0	24,0	20,0	100/25						
70÷95	12	Q95-12	15,0	13,0	44,0	24,0	20,0	100/25						
	16	Q95-16	15,0	17,0	70,0	28,0	20,0	100/25						

CRIMPING CONNECTORS ACCORDING TO DIN 46234

for Copper conductors

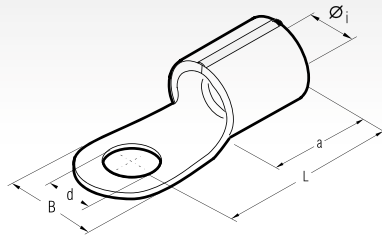

Conductor Size sqmm	Ø Stud mm	Type	Dimensions mm					Quantity Box/Bag	Hydraulic Tools	
			Øi	d	L	B	a		HT120 and tools and heads with 130 kN crimping force	ECW-H3D
95÷120	8	Q120-8	16,5	8,4	44,0	24,0	22,0	100/25		
	10	Q120-10	16,5	10,5	44,0	24,0	22,0	100/25		
	12	Q120-12	16,5	13,0	44,0	24,0	22,0	100/25		
	16	Q120-16	16,5	17,0	48,0	28,0	22,0	50/25		
120:150	10	Q150-10	19,0	10,5	50,0	30,0	24,0	50/25		
	12	Q150-12	19,0	13,0	50,0	30,0	24,0	50/25		
	16	Q150-16	19,0	17,0	50,0	30,0	24,0	50/25		
150÷185	10	Q185-10	21,0	10,5	50,0	36,0	28,0	40/20		
	12	Q185-12	21,0	13,0	50,0	36,0	28,0	40/20		
	16	Q185-16	21,0	17,0	50,0	36,0	28,0	30/15		
185÷240	10	Q240-10	23,5	10,5	56,0	38,0	32,0	10/10		
	12	Q240-12	23,5	13,0	56,0	38,0	32,0	10/10		
	16	Q240-16	23,5	17,0	56,0	38,0	32,0	10/10		

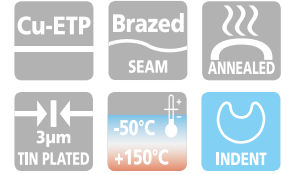

Consult us for special requirements.

Consult us for further information.

for Copper conductors

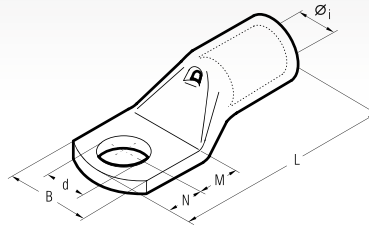

A-M series lugs are manufactured from electrolytic Copper tube with a purity greater than 99.9%. The dimensions of the tube are designed to obtain the most efficient electrical conductivity and mechanical strength to resist vibration and pull out.

Cembre lugs are annealed to guarantee optimum ductility which is an absolute necessity for connectors which will have to withstand the severe deformation arising when compressed and any bending of the palm during installation.

In applications subject to vibration, lugs still have to provide a reliable connection and annealing plays a vital role in avoiding cracking or breaks between the barrel and palm.

The presence of an inspection hole facilitates full insertion of the conductor, whilst the barrel length has been designed to allow easy and accurate positioning of the dies during the crimping operation.

Lugs are electrolytically Tin plated to avoid oxidation. A-M series lugs form an important part of Cembre crimping systems for power carrying conductors, details of the appropriate crimping tools and dies are shown opposite and in detail on pages 248 to 249.

Our technicians are always available to provide any technical advice which may be required.

The enclosed table is only indicative of the range and many variations in stud fixing and palm lengths are also available.

Conductor Size sqmm	Ø Stud mm	Type	Dimensions mm						Quantity Box/Bag	Mechanical Tools	Hydraulic Tools
			Øi	B	M	N	L	d			
0,25÷1,5	3	A03-M3*	1,8	6,0	4,5	3,5	16,0	3,2	5.000/100	HNT	B15MD
	3,5	A03-M3.5*	1,8	6,5	4,5	3,5	16,0	3,7	5.000/100		
	4	A03-M4*	1,8	6,5	5,0	4,0	17,0	4,3	5.000/100		
	5	A03-M5*	1,8	7,5	5,5	4,5	18,0	5,3	5.000/100		
	6	A03-M6*	1,8	9,0	6,0	5,0	19,0	6,4	5.000/100		
1,5÷2,5	3	A06-M3*	2,4	6,0	4,5	3,5	17,0	3,2	4.000/100	HNT	B15MD
	3,5	A06-M3.5*	2,4	6,5	4,5	3,5	17,0	3,7	4.000/100		
	4	A06-M4*	2,4	7,5	5,0	4,0	18,0	4,3	4.000/100		
	5	A06-M5*	2,4	8,5	5,5	4,5	19,0	5,3	4.000/100		
	6	A06-M6*	2,4	9,0	6,0	5,0	20,0	6,4	4.000/100		
4÷6	8	A06-M8*	2,4	12,0	9,0	8,0	26,0	8,4	2.500/100	HNT	B15MD
	3	A1-M3	3,6	7,5	4,5	3,5	20,5	3,2	2.000/100		
	3,5	A1-M3.5	3,6	7,5	4,5	3,5	20,5	3,7	2.000/100		
	4	A1-M4	3,6	8,0	5,0	4,0	21,5	4,3	2.000/100		
	5	A1-M5	3,6	9,0	6,5	6,0	25,0	5,3	2.000/100		
10	6	A1-M6	3,6	11,0	7,0	6,0	25,5	6,4	2.000/100	HNT	B15MD
	8	A1-M8	3,6	14,0	9,0	8,0	29,5	8,4	1.500/100		
	10	A1-M10	3,6	16,5	11,0	10,0	33,5	10,5	1.000/100		
	4	A2-M4	4,6	10,0	5,0	4,0	22,5	4,3	1.500/100		
	5	A2-M5	4,6	10,0	6,5	6,0	26,0	5,3	1.000/100		
16	6	A2-M6	4,6	11,0	7,0	6,0	26,5	6,4	1.000/100	HN5	B15MD
	8	A2-M8	4,6	15,0	9,0	8,0	30,5	8,4	1.000/100		
	10	A2-M10	4,6	18,0	11,0	10,0	34,5	10,5	500/100		
	12	A2-M12	4,6	19,0	14,0	12,0	39,5	13,2	500/100		
	4	A3-M4	5,8	11,5	5,0	4,0	25,5	4,3	1.000/100		
25	5	A3-M5	5,8	11,5	6,5	6,0	29,0	5,3	1.000/100	HN-A25	B15MD
	6	A3-M6	5,8	11,5	7,0	6,0	29,5	6,4	1.000/100		
	8	A3-M8	5,8	15,0	9,0	8,0	33,5	8,4	500/100		
	10	A3-M10	5,8	18,0	11,0	10,0	37,5	10,5	500/100		
	12	A3-M12	5,8	20,0	14,0	12,0	44,0	13,2	500/100		
35	4	A5-M4	7,0	14,0	5,0	4,0	28,0	4,3	1.000/100	TN70SE	B15MD
	5	A5-M5	7,0	14,0	6,5	6,0	31,5	5,3	500/100		
	6	A5-M6	7,0	14,0	7,0	6,0	32,0	6,4	500/100		
	8	A5-M8	7,0	15,0	9,0	8,0	36,0	8,4	500/100		
	10	A5-M10	7,0	18,0	11,0	10,0	40,0	10,5	500/100		
50	12	A5-M12	7,0	21,0	14,0	12,0	45,0	13,2	400/100	TN120SE	B15MD
	5	A7-M5	8,9	17,0	6,5	6,0	34,0	5,3	400/100		
	6	A7-M6	8,9	17,0	7,0	6,0	34,5	6,4	400/100		
	8	A7-M8	8,9	17,0	9,0	8,0	38,5	8,4	400/100		
	10	A7-M10	8,9	19,0	11,0	10,0	42,5	10,5	300/100		
70	12	A7-M12	8,9	21,0	14,0	12,0	47,5	13,2	200/50	TN120SE	B15MD
	6	A10-M6	10,0	19,0	8,0	7,0	38,5	6,4	200/50		
	8	A10-M8	10,0	19,0	9,0	8,0	40,5	8,4	200/50		
	10	A10-M10	10,0	20,0	11,5	9,5	44,5	10,5	200/50		
	12	A10-M12	10,0	21,0	12,0	12,0	47,5	13,2	200/50		
100	14	A10-M14	10,0	25,0	16,0	14,0	55,5	15,0	200/50	TN120SE	B15MD
	16	A10-M16	10,0	26,0	18,0	16,0	59,5	17,0	100/50		
	6	A14-M6	11,3	21,0	8,0	7,0	44,0	6,4	200/50		
	8	A14-M8	11,3	21,0	9,0	8,0	46,0	8,4	200/50		
	10	A14-M10	11,3	21,0	11,0	10,0	50,0	10,5	200/50		
140	12	A14-M12	11,3	22,0	14,0	12,0	55,0	13,2	150/50	TN120SE	B15MD
	14	A14-M14	11,3	25,0	16,0	14,0	59,0	15,0	100/50		
	16	A14-M16	11,3	26,0	18,0	16,0	63,0	17,0	100/50		

*Not UL approved

COPPER TUBE CRIMPING LUGS

for Copper conductors

A-M

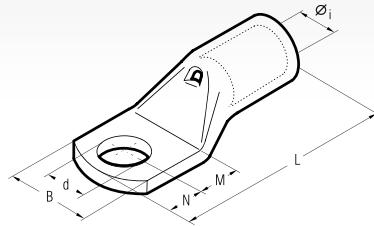

Conductor Size sqmm		Type	Dimensions mm						Quantity Box/Bag	Mechanical Tools	Hydraulic Tools	
Low Str.	Flex*		Øi	B	M	N	L	d				
95	95	6 A19-M6	13,5	25,0	8,0	7,0	50,5	6,4	100/25	TN120SE**	HT45-E B450ND-BV	
		8 A19-M8	13,5	25,0	9,0	8,0	52,5	8,4	100/25			
		10 A19-M10	13,5	25,0	11,0	10,0	56,5	10,5	100/25			
		12 A19-M12	13,5	25,0	14,0	12,0	61,5	13,2	100/25			
		14 A19-M14	13,5	25,0	16,0	14,0	65,5	15,0	100/25			
		16 A19-M16	13,5	27,0	18,0	16,0	69,5	17,0	50/25			
120	120	20 A19-M20	13,5	29,5	22,0	20,0	77,5	21,0	50/25			
		8 A24-M8	15,2	28,5	9,0	8,0	54,0	8,4	75/25			
		10 A24-M10	15,2	28,5	11,0	10,0	58,0	10,5	75/25			
		12 A24-M12	15,2	28,5	14,0	12,0	63,0	13,2	75/25			
		14 A24-M14	15,2	28,5	16,0	14,0	67,0	15,0	50/25			
		16 A24-M16	15,2	28,5	18,0	16,0	71,0	17,0	50/25			
150	150	20 A24-M20	15,2	30,0	22,0	20,0	79,0	21,0	50/25			
		8 A30-M8	16,7	31,5	13,0	11,0	69,0	8,4	50/25			
		10 A30-M10	16,7	31,5	13,0	11,0	69,0	10,5	50/25			
		12 A30-M12	16,7	31,5	16,0	14,0	75,0	13,2	50/25			
		14 A30-M14	16,7	31,5	18,0	16,0	79,0	15,0	50/25			
		16 A30-M16	16,7	31,5	19,0	17,0	81,0	17,0	50/25			
185	185	20 A30-M20	16,7	31,5	22,0	20,0	87,0	21,0	50/25			
		8 A37-M8	19,2	35,5	13,0	11,0	76,0	8,4	50/25			
		10 A37-M10	19,2	35,5	13,0	11,0	76,0	10,5	40/20			
		12 A37-M12	19,2	35,5	16,0	14,0	82,0	13,2	30/15			
		14 A37-M14	19,2	35,5	18,0	16,0	86,0	15,0	30/15			
		16 A37-M16	19,2	35,5	19,0	17,0	88,0	17,0	30/15			
240	240	20 A37-M20	19,2	35,5	22,0	20,0	94,0	21,0	30/15			
		8 A48-M8	21,1	39,0	13,0	11,0	77,5	8,4	20/10			
		10 A48-M10	21,1	39,0	13,0	11,0	77,5	10,5	20/10			
		12 A48-M12	21,1	39,0	14,0	12,0	79,5	13,2	20/10			
		14 A48-M14	21,1	39,0	18,0	16,0	92,0	15,0	20/10			
		16 A48-M16	21,1	39,0	19,0	17,0	94,0	17,0	20/10			
300	300	20 A48-M20	21,1	39,0	22,0	20,0	100,0	21,0	20/10			
		10 A60-M10	23,7	44,0	20,0	11,0	96,0	10,5	20/10			
		12 A60-M12	23,7	44,0	20,0	14,0	99,0	13,2	20/10			
		14 A60-M14	23,7	44,0	22,0	16,0	103,0	15,0	20/10			
		16 A60-M16	23,7	44,0	22,0	19,0	106,0	17,0	20/10			
		20 A60-M20	23,7	44,0	24,0	23,0	112,0	21,0	20/10			
400	400	12 A80-M12	27,0	51,0	22,0	19,0	113,0	13,2	15/5			
		14 A80-M14	27,0	51,0	22,0	19,0	113,0	15,0	15/5			
		16 A80-M16	27,0	51,0	22,0	19,0	113,0	17,0	15/5			
		20 A80-M20	27,0	51,0	24,0	23,0	119,0	21,0	15/5			
		16 A100-M16	30,3	56,5	22,0	19,0	117,0	17,0	10/1			
		20 A100-M20	30,3	56,5	24,0	23,0	123,0	21,0	10/1			
630	630	16 A120-M16*	33,4	61,6	22,0	19,0	128,0	17,0	9/1			
		20 A120-M20*	33,4	61,6	24,0	23,0	134,0	21,0	10/1			
800	630	16 A160-M16*	38,0	72,0	24,0	19,0	141,0	17,0	6/1			
		20 A160-M20*	38,0	72,0	24,0	23,0	145,0	21,0	6/1			
1000	800	16 A200-M16*	44,0	80,0	24,0	19,0	158,0	17,0	5/1			
		20 A200-M20*	44,0	80,0	24,0	23,0	162,0	21,0	5/1			

*Actual conductor section may require a larger lug eg for 120mm² size use A30... lug.

**See page 127



*Not UL approved

for L.V. circuit breakers - for Copper conductors

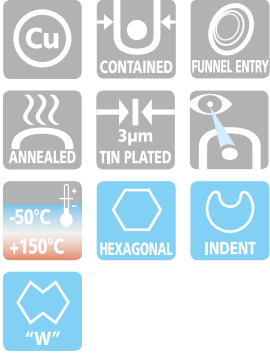
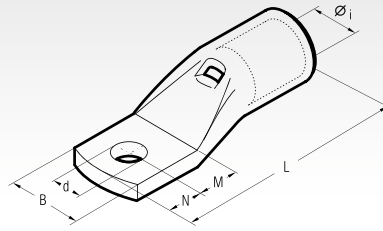

Cond. Size Flexible sqmm	Ø Stud mm	Type	Dimensions mm						Quantity Box/Bag	Mechanical Tools	Hydraulic Tools					
			Øi	B	M	N	L	d			HT45-E	HT51	B500	B600		
10	5	A2-M5/9	4,6	9,0	6,5	6,0	26,0	5,3	1.000/100	HN5 HN-A25	B15MD	B450ND-BV	RH50	RH61	RHU81	ECW-H3D
16	5	A3-M5/9	5,8	9,0	6,5	6,0	29,0	5,3	1.000/100							
25	5	A5-M5/9	7,0	9,0	6,5	6,0	31,5	5,3	500/100	TN70SE	B15MD	B450ND-BV	RH50	RH61	RHU81	ECW-H3D
35	6	A7B-M6/11.5*	8,9	11,5	8,0	7,0	36,5	6,4	400/100							
50	6	A10B-M6/11.5*	10,0	11,5	8,0	7,0	40,5	6,4	200/50	TN120SE	B15MD	B450ND-BV	RH50	RH61	RHU81	ECW-H3D
70	6	A14B-M6/11.5*	11,3	11,5	8,0	7,0	44,0	6,4	200/50							
95	8	A19B-M8/15.5*	13,5	15,5	9,0	8,0	52,5	8,4	100/25	TN120SE	B15MD	B450ND-BV	RH50	RH61	RHU81	ECW-H3D
120	8	A24B-M8/19*	15,2	19,0	14,0	9,0	60,0	8,4	75/25							
120	10	A24B-M10/19*	15,2	19,0	14,0	9,0	60,0	10,5	75/25	TN120SE	B15MD	B450ND-BV	RH50	RH61	RHU81	ECW-H3D
150	8	A30B-M8/19*	16,7	19,0	18,0	9,0	70,0	8,4	50/25							
150	10	A30B-M10/19*	16,7	19,0	18,0	9,0	70,0	10,5	50/25	TN120SE	B15MD	B450ND-BV	RH50	RH61	RHU81	ECW-H3D
185	10	A37B-M10/24.5*	19,2	24,5	18,0	9,0	77,0	10,5	30/15							
240	10	A48-M10/31	21,1	31,0	13,0	9,0	80,0	10,5	20/10	TN120SE	B15MD	B450ND-BV	RH50	RH61	RHU81	ECW-H3D
240	12	A48-M12/31	21,1	31,0	16,0	12,0	86,0	13,2	20/10							
240	16	A48-M16/31	21,1	31,0	19,0	17,0	94,0	17,0	20/10							
300	10	A60B-M10/31*	23,7	31,0	16,0	12,0	95,0	10,5	20/10	TN120SE	B15MD	B450ND-BV	RH50	RH61	RHU81	ECW-H3D
300	12	A60B-M12/31*	23,7	31,0	16,0	12,0	95,0	13,2	20/10							

*Without inspection hole

This range of terminals features contained palm width and has been specifically developed for application on L.V. circuit breakers with reduced space terminal blocks. The contained palm width allows an immediate and easier installation. Cembre terminals are manufactured from electrolytic Copper tube with a purity greater than 99.9%. The specifically designed section of the barrel and the choice of principal dimensions are optimising the best combination of mechanical strength and electrical conductivity. These terminals are annealed to guarantee optimum ductility and are electrolytically Tin plated to avoid oxidation.

The barrel is provided with an internal taper to ease the introduction of the conductor; furthermore, its length grants a comfortable and correct positioning between dies, during crimping operations. Each palm is marked with the Cembre logo and part number.

Details of the appropriate crimping tools and dies are shown on pages 248 to 249.



COPPER TUBE CRIMPING LUGS

for extra flexible Copper conductors

A-M

for fine stranded
SPECIAL
flexible conductors

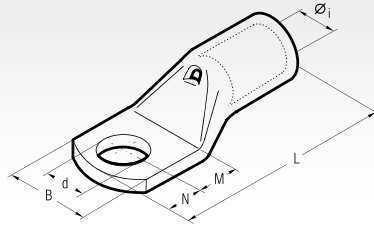

Conductor Size Extra Flexible sqmm	Ø Stud mm	Type	Dimensions mm						Quantity Box/Bag	Mechanical Tools	Hydraulic Tools						
			Øi	B	M	N	L	d									
35	6	A9-M6/15	9,3	15,0	8,0	7,0	38,5	6,4	400/100	TN70SE	HT45-E B450ND-BV						
	8	A9-M8	9,3	17,0	9,0	8,0	40,5	8,4	400/100								
	10	A9-M10	9,3	18,5	11,0	10,0	44,5	10,5	300/100								
	12	A9-M12	9,3	21,0	14,0	12,0	49,5	13,2	300/50								
50	6	A12-M6/15	11,0	15,0	8,0	7,0	40,5	6,4	200/50			TN120SE	HT51 RH50 B500 B500ND				
	8	A12-M8	11,0	19,3	9,0	8,0	42,5	8,4	200/50								
	10	A12-M10	11,0	19,3	11,0	10,0	46,5	10,5	200/50								
	10	A12-M10/19	11,0	19,0	11,0	10,0	46,5	10,5	200/50								
	12	A12-M12	11,0	22,0	14,0	12,0	51,5	13,2	200/50								
70	6	A17-M6	13,0	23,0	8,0	7,0	45,0	6,4	200/50					HT61 RH61 B600	HT81-U RHU81		
	8	A17-M8	13,0	23,0	9,0	8,0	47,0	8,4	150/50								
	10	A17-M10	13,0	23,0	11,0	10,0	51,0	10,5	150/50								
	10	A17-M10/19	13,0	19,0	11,0	10,0	51,0	10,5	200/50								
	12	A17-M12	13,0	23,0	14,0	12,0	56,0	13,2	150/50								
	14	A17-M14	13,0	25,0	15,5	12,0	57,5	15,0	150/25								
95	16	A17-M16	13,0	27,0	16,5	13,5	60,0	17,0	100/25							ECW-H3D	RHU520
	8	A20-M8	15,0	27,0	9,0	8,0	50,0	8,4	100/25								
	10	A20-M10	15,0	27,0	11,0	10,0	54,0	10,5	100/25								
	12	A20-M12	15,0	27,0	14,0	12,0	59,0	13,2	100/25								
	14	A20-M14	15,0	27,0	15,5	12,0	60,5	15,0	100/25								
120	16	A20-M16	15,0	27,0	16,5	13,5	63,0	17,0	100/25	HT120 and tools and heads with 130 kN crimping force							
	8	A29-M8	16,5	30,0	9,0	8,0	53,5	8,4	100/25								
	10	A29-M10	16,5	30,0	11,0	10,0	57,5	10,5	50/25								
	12	A29-M12	16,5	30,0	14,0	12,0	62,5	13,2	50/25								
	14	A29-M14	16,5	30,0	15,5	12,0	64,0	15,0	100/25								
	16	A29-M16	16,5	30,0	16,5	13,5	66,5	17,0	100/25								
150	20	A29-M20	16,5	30,0	22,0	20,0	78,5	21,0	75/25		HT120 and tools and heads with 130 kN crimping force						
	10	A35-M10	19,2	34,2	13,0	11,0	65,5	10,5	50/25								
	12	A35-M12	19,2	34,2	16,0	14,0	71,5	13,2	50/25								
	14	A35-M14	19,2	34,2	18,0	16,0	75,5	15,0	50/25								
	16	A35-M16	19,2	34,2	19,0	17,0	77,5	17,0	30/15								
185	20	A35-M20	19,2	34,2	22,0	20,0	83,5	21,0	50/25			HT120 and tools and heads with 130 kN crimping force					
	10	A40-M10	21,0	37,5	13,0	11,0	73,0	10,5	30/15								
	12	A40-M12	21,0	37,5	16,0	14,0	79,0	13,2	30/15								
	14	A40-M14	21,0	37,5	18,0	16,0	83,0	15,0	30/15								
185	16	A40-M16	21,0	37,5	19,0	17,0	85,0	17,0	30/15				HT120 and tools and heads with 130 kN crimping force				
	20	A40-M20	21,0	37,5	22,0	20,0	91,0	21,0	30/15								



These lugs are particularly recommended for use with extra flexible conductors on for instance, welding machines.

A-M series lugs are designed to suit panel applications.

The dimensions of the tube are designed to obtain the most efficient electrical conductivity and mechanical strength to resist vibration and pull out.

Cembre lugs are annealed to guarantee optimum ductility and electrolytically Tin plated to avoid oxidation.

The presence of an inspection hole facilitates full insertion of the conductor.

Details of the appropriate crimping tools and dies are shown on pages 248 to 249.

for Copper conductors

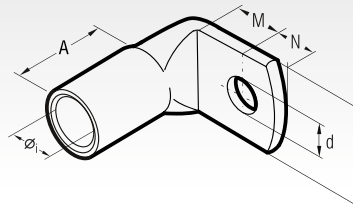

A-L series lugs angled 90° are manufactured from electrolytic Copper tube with a purity greater than 99.9%.

The dimensions of the tube are designed to obtain the most efficient electrical conductivity and mechanical strength to resist vibration and pull out.

Cembre lugs are annealed to guarantee optimum ductility which is an absolute necessity for connectors which will have to withstand the severe deformation arising when compressed and any bending of the palm during installation.

In applications subject to vibration, terminals still have to perform a reliable connection, annealing plays a vital role in avoiding cracking or breaks between the barrel and palm.

The presence of an inspection hole facilitates full insertion of the conductor, whilst the barrel length has been designed to allow easy and accurate positioning of the dies during the crimping operation.

Lugs are electrolytically Tin plated to avoid oxidation.

Details of the appropriate crimping tools and dies are shown on pages 248 to 249.

Conductor Size sqmm	Ø Stud mm	Type	Dimensions mm						Quantity Box/Bag	Mechanical Tools	Hydraulic Tools
			Øi	B	M	N	A	d			
6	6	A1-L6*	3,6	11,0	7,0	6,0	9,5	6,4	2.000/100	HN1	B15MD
	5	A2-L5	4,6	10,0	6,5	6,0	10,5	5,3	1.500/100		
10	6	A2-L6	4,6	11,0	7,0	6,0	10,5	6,4	1.000/100	HN5	B15MD
	8	A2-L8	4,6	15,0	9,0	8,0	10,5	8,4	500/100		
16	5	A3-L5	5,8	11,5	6,5	6,0	11,5	5,3	1.000/100	HN-A25	B15MD
	6	A3-L6	5,8	11,5	7,0	6,0	11,5	6,4	1.000/100		
	8	A3-L8	5,8	15,0	9,0	8,0	11,5	8,4	1.000/100		
	10	A3-L10	5,8	18,0	11,0	10,0	11,5	10,5	500/100		
25	6	A5-L6	7,0	14,0	7,0	6,0	13,0	6,4	500/100	TN70SE	B15MD
	8	A5-L8	7,0	15,0	9,0	8,0	13,0	8,4	500/100		
	10	A5-L10	7,0	18,0	11,0	10,0	13,0	10,5	500/100		
35	6	A7-L6	8,9	17,0	7,0	6,0	15,5	6,4	300/100	TN120SE**	B15MD
	8	A7-L8	8,9	17,0	9,0	8,0	15,5	8,4	300/100		
	10	A7-L10	8,9	19,0	11,0	10,0	15,5	10,5	400/100		
	12	A7-L12	8,9	21,0	14,0	12,0	15,5	13,2	300/100		
50	6	A10-L6	10,0	19,0	8,0	7,0	16,5	6,4	300/100	TN120SE**	B15MD
	8	A10-L8	10,0	19,0	9,0	8,0	16,5	8,4	300/100		
	10	A10-L10	10,0	20,0	11,5	9,5	16,5	10,5	200/50		
	12	A10-L12	10,0	21,0	12,0	12,0	16,5	13,2	200/50		
70	8	A14-L8	11,3	21,0	9,0	8,0	20,0	8,4	200/50	TN120SE**	B15MD
	10	A14-L10	11,3	21,0	11,0	10,0	20,0	10,5	100/50		
	12	A14-L12	11,3	22,0	14,0	12,0	20,0	13,2	100/50		
95	16	A14-L16	11,3	26,0	18,0	16,0	20,0	17,0	150/50	TN120SE**	B15MD
	8	A19-L8	13,5	25,0	9,0	8,0	24,5	8,4	100/25		
120	10	A19-L10	13,5	25,0	11,0	10,0	24,5	10,5	100/25	TN120SE**	B15MD
	12	A19-L12	13,5	25,0	14,0	12,0	24,5	13,2	100/25		
	10	A24-L10	15,2	28,5	11,0	10,0	25,5	10,5	50/25		
150	12	A24-L12	15,2	28,5	14,0	12,0	25,5	13,2	50/25	TN120SE**	B15MD
	10	A30-L10	16,7	31,5	13,0	11,0	28,5	10,5	50/25		
185	12	A30-L12	16,7	31,5	16,0	14,0	28,5	13,2	50/25	TN120SE**	B15MD
	10	A37-L10	19,2	35,5	13,0	11,0	31,5	10,5	30/15		
240	12	A37-L12	19,2	35,5	16,0	14,0	31,5	13,2	50/25	TN120SE**	B15MD
	10	A48-L10	21,1	39,0	13,0	11,0	33,0	10,5	30/15		
300	12	A48-L12	21,1	39,0	16,0	14,0	33,0	13,2	30/15	TN120SE**	B15MD
	12	A60-L12	23,7	44,0	20,0	14,0	42,0	13,2	20/10		

*Actual conductor section may require a larger lug eg for 120mm² size use A30-... lug.

**See page 135

*Not UL approved

COPPER TUBE CRIMPING LUGS

double hole fixing - for Copper conductors

A-2M

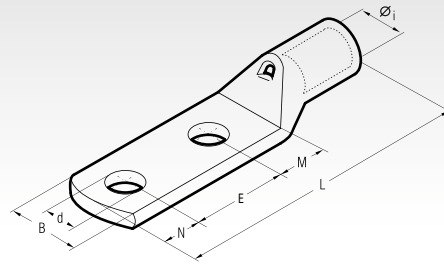

Conductor Size sqmm	Ø Stud mm	Type	Dimensions mm							Quantity Box/Bag	Mechanical Tools	Hydraulic Tools
			Øi	B	M	N	E	L	d			
10	4	A2-2M4-12	4,6	10,0	5,0	4,0	12,0	36,5	4,3	100	HN1 HNS HN-A25	B15MD
	8	A2-2M8-20	4,6	15,0	11,0	11,0	20,0	57,5	8,4	100		
16	8	A3-2M8-20	5,8	15,0	11,0	11,0	20,0	62,0	8,4	50	HN-A25	B15MD
	12	A3-2M12-40	5,8	20,0	14,0	12,0	40,0	82,5	13,2	200/50		
25	8	A5-2M8-20	7,0	15,0	9,0	11,0	20,0	59,0	8,4	400/100	HN-A25	B15MD
	8	A5-2M8-24-24	7,0	15,0	24,0	11,0	24,0	78,0	8,4	300/100		
	10	A5-2M10-24-13	7,0	18,0	13,0	11,0	24,0	67,0	10,5	300/100		
35	10	A7-2M10	8,9	19,0	11,0	10,0	44,5	87,0	10,5	100/50	TN70SE	B15MD
	10	A7-2M10-25	8,9	19,0	12,0	11,0	25,0	69,5	10,5	100		
	12	A7-2M12	8,9	21,0	16,0	14,0	44,5	96,0	13,2	200/100		
	12	A7-2M12-25	8,9	21,0	16,0	14,0	25,0	76,5	13,2	50		
	12	A7-2M12-40	8,9	21,0	16,0	14,0	40,0	91,5	13,2	150/50		
50	6	A10-2M6	10,0	19,0	8,0	11,0	44,5	89,0	6,4	50	TN70SE	B15MD
	8	A10-2M8	10,0	19,0	11,0	11,0	44,5	92,0	8,4	100/50		
	8	A10-2M8-20	10,0	19,0	11,0	11,0	20,0	67,5	8,4	200/50		
	8	A10-2M8-22	10,0	19,0	11,0	11,0	22,0	69,5	8,4	150/50		
	8	A10-2M8-30	10,0	19,0	11,0	11,0	30,0	77,5	8,4	150/50		
	8	A10-2M8-24-24	10,0	19,0	24,0	11,0	24,0	84,5	8,4	150/50		
	10	A10-2M10	10,0	20,0	13,0	11,0	44,5	94,0	10,5	100/50		
	10	A10-2M10-24-13	10,0	19,0	13,0	11,0	24,0	73,5	10,5	150/50		
	12	A10-2M12	10,0	21,0	16,0	14,0	44,5	100	13,2	100/50		
	12	A10-2M12-25	10,0	21,0	16,0	14,0	25,0	80,5	13,2	50		
70	8	A14-2M8	11,3	21,0	11,0	11,0	44,5	95,5	8,4	50	TN120SE	B15MD
	8	A14-2M8-24-24	11,3	21,0	24,0	11,0	24,0	88,0	8,4	100/50		
	10	A14-2M10	11,3	21,0	13,0	11,0	44,5	97,5	10,5	100/50		
	10	A14-2M10-24	11,3	21,0	13,0	11,0	24,0	77,0	10,5	100/50		
	12	A14-2M12	11,3	22,0	16,0	14,0	44,5	103,5	13,2	100/50		
	12	A14-2M12-25	11,3	22,0	16,0	14,0	25,0	84,0	13,2	50		
	12	A14-2M12-30-29	11,3	22,0	29,0	14,0	30,0	102,0	13,2	100/50		
	12	A14-2M12-40	11,3	22,0	16,0	14,0	40,0	99,0	13,2	100/50		
14	A14-2M14	11,3	25,0	18,0	16,0	44,5	107,5	15,0	100/50			
95	6	A19-2M6	13,5	25,0	10,0	11,0	44,5	101,0	6,4	25	TN120SE	B15MD
	8	A19-2M8-50S	13,5	25,0	15,0	15,0	50,0	115,5	8,4	75/25		
	10	A19-2M10	13,5	25,0	13,0	11,0	44,5	104,0	10,5	50/25		
	10	A19-2M10-24-13	13,5	25,0	13,0	11,0	24,0	83,5	10,5	75/25		
	10	A19-2M10-24-26	13,5	25,0	26,0	11,0	24,0	96,5	10,5	50/25		
	10	A19-2M10-40	13,5	25,0	13,0	11,0	40,0	99,5	10,5	75/25		
	12	A19-2M12	13,5	25,0	16,0	14,0	44,5	110,0	13,2	75/25		
	12	A19-2M12-25	13,5	25,0	16,0	14,0	25,0	90,5	13,2	25		
	12	A19-2M12-30-29	13,5	25,0	29,0	14,0	30,0	108,5	13,2	50/25		
	14	A19-2M14	13,5	25,0	18,0	16,0	44,5	114,0	15,0	100/25		
120	14	A19-2M14-25	13,5	25,0	18,0	16,0	25,0	94,5	15,0	25	TN120SE	B15MD
	16	A19-2M16	13,5	25,0	19,0	17,0	44,5	116,0	17,0	50/25		
	8	A24-2M8-20	15,2	28,5	11,0	11,0	20,0	79,0	8,4	25		
	8	A24-2M8-24-29	15,2	28,5	29,0	11,0	24,0	101,0	8,4	50/25		
	10	A24-2M10	15,2	28,5	13,0	11,0	44,5	105,5	10,5	50/25		
	10	A24-2M10-22	15,2	28,5	13,0	11,0	22,0	83,0	10,5	25		
	10	A24-2M10-25/24	15,2	24,0	13,0	11,0	25,0	86,0	10,5	50/25		
	10	A24-2M10-33.5	15,2	28,5	13,0	11,0	33,5	94,5	10,5	50/25		
	10	A24L-2M10-30AS	15,2	28,5	13,0	11,0	30,0	91,0	10,5	25		
	12	A24-2M12	15,2	28,5	16,0	14,0	44,5	113,0	13,2	50/25		
	12	A24-2M12-30-29	15,2	28,5	29,0	14,0	30,0	110,0	13,2	50/25		
	12	A24-2M12-40	15,2	28,5	16,0	14,0	40,0	107,0	13,2	50/25		
14	A24-2M14	15,2	28,5	18,0	16,0	44,5	115,5	15,0	50/25			
16	A24-2M16	15,2	28,5	19,0	17,0	44,5	117,5	17,0	50/25			



A-2M series lugs are manufactured from electrolytic copper tube with a purity greater than 99.9%.

The dimensions of the tube are designed to obtain the most efficient electrical conductivity and mechanical strength to resist vibration and pull out.

The double hole fixing ensures greater mechanical stability even in the presence of electrodynamic stresses. Cembre lugs are annealed to guarantee optimum ductility, an absolute necessity for connectors which will have to withstand the severe deformation arising when compressed and any bending of the palm during installation.

In applications subject to vibration, terminals still have to perform a reliable connection, annealing plays a vital role in avoiding cracking or breaks between the barrel and palm.

The presence of an inspection hole facilitates full insertion of the conductor, whilst the barrel length has been designed to allow easy and accurate positioning of the dies during the crimping operation.

Lugs are electrolytically tinplated to avoid oxidation.

A-2M series lugs form an important part of Cembre crimping systems for power carrying conductors, details of the appropriate crimping tools and dies are shown opposite and in detail on page 248-249, whilst our technicians are always available to provide any technical advice which may be required.

The enclosed table is only indicative of the range and many variations in stud fixing and palm lengths are also available.

double hole fixing - for Copper conductors

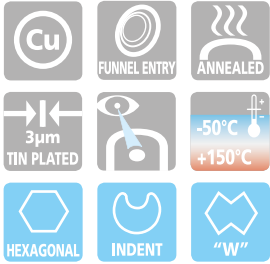
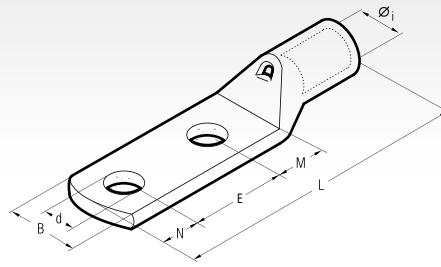

Conductor Size sqmm	Ø Stud mm	Type	Dimensions mm							Quantity Box/Bag	Mechanical Tools	Hydraulic Tools
			Øi	B	M	N	E	L	d			
150	8	A30-2M8-20	16,7	31,5	13,0	11,0	20,0	89,0	8,4	50/25	TN120SE*	RH50 B500 B500ND HT51 RH61 B600 HT81-U RHU81 HT120 and tools and heads with 130 kN crimping force ECW-H3D RHU520
	10	A30-2M10	16,7	31,5	13,0	11,0	44,5	113,5	10,5	50/25		
	10	A30-2M10-24-28	16,7	31,5	28,0	11,0	24,0	108,0	10,5	50/25		
	12	A30-2M12	16,7	31,5	16,0	14,0	44,5	119,5	13,2	50/25		
	12	A30-2M12-30	16,7	31,5	16,0	14,0	30,0	105,0	13,2	50/25		
	12	A30-2M12-30-29	16,7	31,5	29,0	14,0	30,0	118,0	13,2	30/15		
	12	A30-2M12-40	16,7	31,5	16,0	14,0	40,0	115,0	13,2	30/15		
	14	A30-2M14	16,7	31,5	18,0	16,0	44,5	123,5	15,0	50/25		
	14	A30-2M14-33.5	16,7	31,5	18,0	16,0	33,5	112,5	15,0	50/25		
185	10	A37-2M10	19,2	35,5	13,0	11,0	44,5	120,5	10,5	30/15	HT51	
	10	A37-2M10-25	19,2	35,5	13,0	11,0	25,0	101,0	10,5	30/15		
	12	A37-2M12	19,2	35,5	16,0	14,0	44,5	126,5	13,2	30/15		
	12	A37-2M12-32	19,2	35,5	16,0	14,0	32,0	114,0	13,2	30/15		
	12	A37-2M12-30-31	19,2	35,5	31,0	14,0	30,0	127,0	13,2	30/15		
	14	A37-2M14	19,2	35,5	18,0	16,0	44,5	130,5	15,0	30/15		
	14	A37-2M14-35	19,2	35,5	18,0	16,0	35,0	121,0	15,0	15		
	16	A37-2M16	19,2	35,5	19,0	17,0	44,5	132,5	17,0	30/15		
	16	A37-2M16-40	19,2	35,5	19,0	17,0	40,0	128,0	17,0	15		
240	10	A48-2M10	21,1	39,0	13,0	11,0	44,5	126,5	10,5	30/15	RH50 B500 B500ND HT51 RH61 B600 HT81-U RHU81 HT120 and tools and heads with 130 kN crimping force ECW-H3D RHU520	
	10	A48-2M10-20	21,1	39,0	13,0	11,0	20,0	102,0	10,5	15		
	10	A48-2M10-35	21,1	39,0	13,0	11,0	35,0	117,0	10,5	15		
	12	A48-2M12	21,1	39,0	16,0	14,0	44,5	132,5	13,2	30/15		
	12	A48-2M12-35	21,1	39,0	16,0	14,0	35,0	123,0	13,2	30/15		
	12	A48-2M12-40	21,1	39,0	16,0	14,0	40,0	128,0	13,2	30/15		
	12	A48-2M12-30-31	21,1	39,0	31,0	14,0	30,0	133,0	13,2	20/10		
	14	A48-2M14	21,1	39,0	18,0	16,0	44,5	136,5	15,0	30/15		
	14	A48-2M14-40	21,1	39,0	18,0	16,0	40,0	132,0	15,0	30/15		
300	16	A48-2M16	21,1	39,0	19,0	17,0	44,5	138,5	17,0	30/15	RH50 B500 B500ND HT51 RH61 B600 HT81-U RHU81 HT120 and tools and heads with 130 kN crimping force ECW-H3D RHU520	
	10	A60-2M10	23,7	44,0	13,0	11,0	44,5	133,5	10,5	20/5		
	12	A60-2M12	23,7	44,0	20,0	14,0	44,5	143,5	13,2	20/5		
	12	A60-2M12-40	23,7	44,0	20,0	14,0	40,0	139,0	13,2	20/5		
	12	A60-2M12-30-38	23,7	44,0	38,0	14,0	30,0	147,0	13,2	20/5		
	14	A60-2M14	23,7	44,0	22,0	16,0	44,5	147,5	15,0	20/5		
	16	A60-2M16-40	23,7	44,0	22,0	17,0	40,0	144,0	17,0	20/5		
	16	A60-2M16	23,7	44,0	22,0	17,0	44,5	148,5	17,0	20/5		
	16	A60-2M16-35	23,7	44,0	22,0	17,0	35,0	139,0	17,0	20/5		
400	16	A60-2M16/36	23,7	36,0	22,0	17,0	44,5	148,5	17,0	20/5	RH50 B500 B500ND HT51 RH61 B600 HT81-U RHU81 HT120 and tools and heads with 130 kN crimping force ECW-H3D RHU520	
	12	A80-2M12	27,0	51,0	22,0	14,0	44,5	152,5	13,2	15/5		
	14	A80-2M14	27,0	51,0	22,0	16,0	44,5	154,5	15,0	15/5		
	14	A80-2M14-40	27,0	51,0	22,0	16,0	40,0	150,0	15,0	15/5		
	16	A80-2M16	27,0	51,0	22,0	19,0	44,5	157,5	17,0	15/5		
	16	A80-2M16-40	27,0	51,0	22,0	19,0	40,0	153,0	17,0	15/5		
	16	A80-2M16/41	27,0	41,0	22,0	19,0	44,5	157,5	17,0	15/5		
	16	A80-2M16-50	27,0	51,0	22,0	19,0	50,0	163,0	17,0	5		
	12	A100-2M12	30,3	56,5	20,0	14,0	44,5	152,0	13,2	10/1		
500	14	A100-2M14-40	30,3	56,5	17,0	16,0	40,0	149,0	15,0	1	RH50 B500 B500ND HT51 RH61 B600 HT81-U RHU81 HT120 and tools and heads with 130 kN crimping force ECW-H3D RHU520	
	14	A100-2M14	30,3	56,5	17,0	16,0	44,5	153,5	15,0	10/1		
	16	A100-2M16	30,3	56,5	19,0	19,0	44,5	158,5	17,0	10/5		
630	12	A120-2M12*	33,4	61,6	22,0	14,0	44,5	167,5	13,2	20/5	RH50 B500 B500ND HT51 RH61 B600 HT81-U RHU81 HT120 and tools and heads with 130 kN crimping force ECW-H3D RHU520	
	16	A120-2M16*	33,4	61,6	22,0	19,0	44,5	172,5	17,0	10/1		
800	12	A160-2M12*	38,0	72,0	20,0	14,0	44,5	176,5	13,2	9/3	RH50 B500 B500ND HT51 RH61 B600 HT81-U RHU81 HT120 and tools and heads with 130 kN crimping force ECW-H3D RHU520	
	16	A160-2M16*	38,0	72,0	22,0	19,0	44,5	183,5	17,0	9/3		

*See page 135

♦Not UL approved

COPPER TUBE CRIMPING LUGS ANGLED 315° and 345°

A-2M

double hole fixing - for Copper conductors

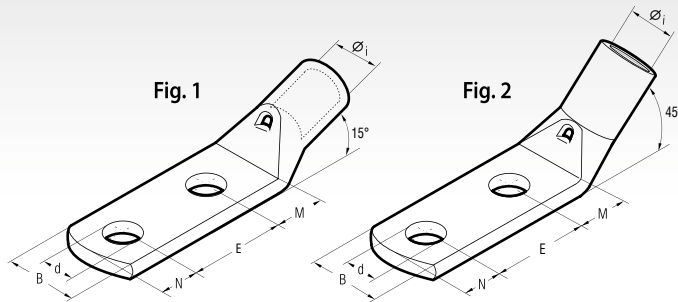

Conductor Size sqmm	Ø Stud mm	Type	Fig. N.	Dimensions mm						Quantity Box/Bag	Mechanical Tools	Hydraulic Tools
				Øi	B	M	N	E	d			
25	8	A5-2M8-24-24/345	1	7,0	15,0	24,0	11,0	24,0	8,4	300/100	HN-A25	HT45-E B450ND-BV
	12	A5-2M12-30-29/345	1	7,0	21,0	29,0	14,0	30,0	13,2	200/100		
50	8	A10-2M8-24-24/345	1	10,0	19,0	24,0	11,0	24,0	8,4	150/50	TN70SE	RH50 B500ND HT61 RH61 B600
	10	A14-2M10-24-26/315	2	11,3	21,0	26,0	11,0	24,0	10,5	100/50		
70	10	A14-2M10-24-26/345	1	11,3	21,0	26,0	11,0	24,0	10,5	100/50	TN120SE*	HT81-U RHU81
	12	A14-2M12-30-29/345	1	11,3	22,0	29,0	14,0	30,0	13,2	100/50		
95	8	A19-2M8-24-24/345	1	13,5	25,0	24,0	11,0	24,0	8,4	75/25	TN120SE*	ECW-H3D RHU520
	10	A19-2M10-24-26/345	1	13,5	25,0	26,0	11,0	24,0	10,5	25		
120	12	A19-2M12-30-29/345	1	13,5	25,0	29,0	14,0	30,0	13,2	75/25	TN120SE*	RH50 B500ND HT61 RH61 B600
	8	A24-2M8-24-29/345	1	15,2	28,5	29,0	11,0	24,0	8,4	50/25		
150	10	A24-2M10-24-29/345	1	15,2	28,5	29,0	11,0	24,0	10,5	50/25	TN120SE*	RH50 B500ND HT61 RH61 B600
	12	A24-2M12-30-29/345	1	15,2	28,5	29,0	14,0	30,0	13,2	50/25		
185	8	A30-2M8-24-29/345	1	16,7	31,5	29,0	11,0	24,0	8,4	30/15	TN120SE*	RH50 B500ND HT61 RH61 B600
	10	A30-2M10-24-28/345	1	16,7	31,5	28,0	11,0	24,0	10,5	50/25		
240	12	A30-2M12-30-29/345	1	16,7	31,5	29,0	14,0	30,0	13,2	40/20	TN120SE*	RH50 B500ND HT61 RH61 B600
	10	A37-2M10-25/315	2	19,2	35,5	13,0	11,0	25,0	10,5	15		
300	12	A37-2M12-30-31/345	1	19,2	35,5	31,0	14,0	30,0	13,2	30/15	TN120SE*	RH50 B500ND HT61 RH61 B600
	12	A48-2M12/345	1	21,1	39,0	16,0	14,0	44,5	13,2	20/10		
300	12	A48-2M12-30/45	1	21,1	39,0	16,0	14,0	30,0	13,2	20/10	TN120SE*	RH50 B500ND HT61 RH61 B600
	12	A48-2M12-30-31/345	1	21,1	39,0	31,0	14,0	30,0	13,2	20/10		
300	12	A60-2M12-30-38/345	1	23,7	44,0	38,0	14,0	30,0	13,2	20/10	TN120SE*	RH50 B500ND HT61 RH61 B600

*See page 135



A-2M series lugs angled 315° and 345° are manufactured from electrolytic copper tube with a purity greater than 99.9%.

The dimensions of the tube are designed to obtain the most efficient electrical conductivity and mechanical strength to resist vibration and pull out.

The double hole fixing ensures greater mechanical stability even in the presence of electrodynamic stresses. Cembre lugs are annealed to guarantee optimum ductility, an absolute necessity for connectors which will have to withstand the severe deformation arising when compressed and any bending of the palm during installation.

In applications subject to vibration, terminals still have to perform a reliable connection, annealing plays a vital role in avoiding cracking or breaks between the barrel and palm.

The presence of an inspection hole facilitates full insertion of the conductor, whilst the barrel length has been designed to allow easy and accurate positioning of the dies during the crimping operation.

Lugs are electrolytically tinplated to avoid oxidation.

Details of the appropriate crimping tools and dies are shown on pages 248 to 249.

2A-M

HEAVY DUTY COPPER TUBE TERMINALS

for Copper conductors

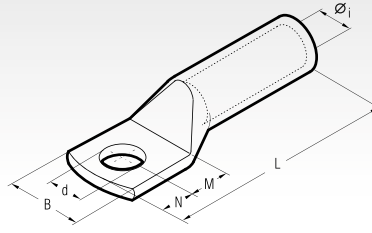

2A-M series terminals are made from high purity Copper tube with a purity greater than 99.9%, and are annealed.

They feature a double length barrel for enhanced electrical and mechanical performance in heavy duty applications.

The absence of an inspection hole prevents the entry of water or moisture into the crimped joint making these terminals suitable for outdoor applications.

The terminals are electrolytically Tin plated to prevent atmospheric corrosion.

Details of the appropriate crimping tools and dies are shown on pages 248 to 249.

Conductor Size sqmm	Ø Stud mm	Type	Dimensions mm						Quantity Box/Bag	Mechanical Tools	Hydraulic Tools		
			Øi	B	M	N	L	d					
16	8	2A3-M8	5,8	15,0	9,0	8,0	43,5	8,4	600/100	HN5	B15MD		
	10	2A3-M10	5,8	18,0	11,0	10,0	47,5	10,5	500/100				
25	8	2A5-M8	7,0	15,0	9,0	8,0	51,0	8,4	400/100	HN-A25			
	10	2A5-M10	7,0	18,0	11,0	10,0	55,0	10,5	300/50				
35	12	2A5-M12	7,0	21,0	14,0	12,0	60,0	13,2	300/50	TN70SE			
	8	2A7-M8	8,9	17,0	9,0	8,0	53,0	8,4	250/50				
50	10	2A7-M10	8,9	19,0	11,0	10,0	57,0	10,5	200/50	TN70SE			
	12	2A7-M12	8,9	21,0	14,0	12,0	62,0	13,2	200/50				
63	10	2A10-M10	10,0	20,0	11,0	10,0	63,0	10,5	100/50	TN120 SE*			
	12	2A10-M12	10,0	21,0	14,0	12,0	68,0	13,2	100/50				
70	14	2A10-M14	10,0	25,0	16,0	14,0	72,0	15,0	150/50	TN120 SE*			
	16	2A10-M16	10,0	26,0	18,0	16,0	76,0	17,0	150/50				
95	10	2A14-M10	11,3	21,0	11,0	10,0	70,0	10,5	100/50	TN120 SE*			
	12	2A14-M12	11,3	22,0	14,0	12,0	75,0	13,2	100/50				
120	14	2A14-M14	11,3	25,0	16,0	14,0	79,0	15,0	100/50	TN120 SE*			
	16	2A14-M16	11,3	26,0	18,0	16,0	83,0	17,0	100/50				
125	10	2A19-M10	13,5	25,0	11,0	10,0	76,5	10,5	50/25	TN120 SE*			
	12	2A19-M12	13,5	25,0	14,0	12,0	81,5	13,2	50/25				
150	14	2A19-M14	13,5	25,0	16,0	14,0	85,5	15,0	75/25	TN120 SE*			
	16	2A19-M16	13,5	27,0	18,0	16,0	90,5	17,0	50/25				
185	20	2A19-M20	13,5	29,5	22,0	20,0	97,5	21,0	75/25	TN120 SE*			
	10	2A24-M10	15,2	28,5	11,0	10,0	82,0	10,5	30/15				
240	12	2A24-M12	15,2	28,5	14,0	12,0	87,0	13,2	30/15	TN120 SE*			
	14	2A24-M14	15,2	28,5	16,0	14,0	91,0	15,0	30/15				
300	16	2A24-M16	15,2	28,5	18,0	16,0	95,0	17,0	30/15	TN120 SE*			
	20	2A24-M20	15,2	30,0	22,0	20,0	103,0	21,0	50/25				
400	10	2A30-M10	16,7	31,5	13,0	11,0	92,0	10,5	50/25	TN120 SE*			
	12	2A30-M12	16,7	31,5	16,0	14,0	98,0	13,2	30/15				
500	14	2A30-M14	16,7	31,5	18,0	16,0	102,0	15,0	30/15	TN120 SE*			
	16	2A30-M16	16,7	31,5	19,0	17,0	104,0	17,0	30/15				
630	20	2A30-M20	16,7	31,5	22,0	20,0	110,0	21,0	30/15	TN120 SE*			
	12	2A37-M12	19,2	35,5	16,0	14,0	108,0	13,2	20/10				
800	14	2A37-M14	19,2	35,5	18,0	16,0	112,0	15,0	30/15	TN120 SE*			
	16	2A37-M16	19,2	35,5	19,0	17,0	114,0	17,0	30/15				
1000	20	2A37-M20	19,2	35,5	22,0	20,0	120,0	21,0	30/15	TN120 SE*			
	12	2A48-M12	21,1	39,0	16,0	14,0	109,0	13,2	20/5				
1200	14	2A48-M14	21,1	39,0	18,0	16,0	113,0	15,0	20/5	TN120 SE*			
	16	2A48-M16	21,1	39,0	19,0	17,0	115,0	17,0	20/5				
1500	20	2A48-M20	21,1	39,0	22,0	20,0	121,0	21,0	25/5	TN120 SE*			
	12	2A60-M12	23,7	44,0	20,0	14,0	129,5	13,2	20/5				
2000	14	2A60-M14	23,7	44,0	22,0	16,0	133,5	15,0	20/5	TN120 SE*			
	16	2A60-M16	23,7	44,0	22,0	19,0	136,5	17,0	20/5				
2500	20	2A60-M20	23,7	44,0	24,0	23,0	142,5	21,0	20/5	TN120 SE*			
	12	2A80-M12	27,0	51,0	22,0	19,0	140,0	13,2	15/5				
3000	14	2A80-M14	27,0	51,0	22,0	19,0	140,0	15,0	10/5	TN120 SE*			
	16	2A80-M16	27,0	51,0	22,0	19,0	140,0	17,0	10/5				
3500	20	2A80-M20	27,0	51,0	24,0	23,0	146,0	21,0	15/5	TN120 SE*			
	16	2A100-M16*	30,3	56,5	22,0	19,0	141,0	17,0	10/1				
4000	20	2A100-M20*	30,3	56,5	24,0	23,0	147,0	21,0	10/1	TN120 SE*			
	12	2A120-M16*	33,4	61,5	22,0	19,0	159,0	17,0	20/1				
4500	20	2A120-M20*	33,4	61,5	24,0	23,0	165,0	21,0	20/1	TN120 SE*			
	800	20	2A160-M20*	38,0	72,0	24,0	23,0	187,0	21,0				12/1
5000	1000	20	2A200-M20*	44,0	80,0	24,0	23,0	202,0	21,0	6/1	TN120 SE*		

*See page 135

*Not UL approved

HEAVY DUTY COPPER TUBE TERMINALS

2A-2M

double hole fixing - for Copper conductors

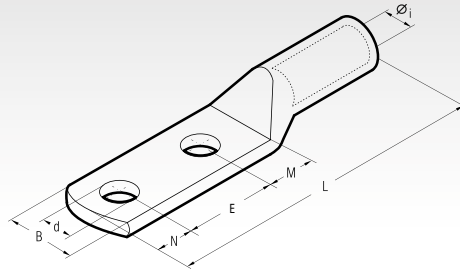

Conductor Size sqmm	Ø Stud mm	Type	Dimensions mm							Quantity Box/Bag	Mechanical Tools	Hydraulic Tools								
			Øi	B	M	N	E	L	d			HT45-E	B450ND-BV	RH50	B500	HT61	RH61	B600	HT81-U	RHU81
50	12	2A10-2M12	10,0	21,0	14,0	12,0	44,5	112,5	13,2	75/25	TN70SE	HT45-E	B450ND-BV	RH50	B500	HT61	RH61	B600	HT81-U	RHU81
	12	2A14-2M12	11,3	22,0	16,0	14,0	44,5	123,5	13,2	50/25										
70	14	2A14-2M14	11,3	25,0	18,0	16,0	44,5	127,5	15,0	75/25	TN120 SE*	HT45-E	B450ND-BV	RH50	B500	HT61	RH61	B600	HT81-U	RHU81
	12	2A19-2M12	13,5	25,0	16,0	14,0	44,5	128,0	13,2	50/25										
95	14	2A19-2M14	13,5	25,0	18,0	16,0	44,5	132,0	15,0	50/25	TN120 SE*	HT45-E	B450ND-BV	RH50	B500	HT61	RH61	B600	HT81-U	RHU81
	12	2A24-2M12	15,2	28,5	16,0	14,0	44,5	135,5	13,2	50/25										
120	14	2A24-2M14	15,2	28,5	18,0	16,0	44,5	139,5	15,0	50/25	TN120 SE*	HT45-E	B450ND-BV	RH50	B500	HT61	RH61	B600	HT81-U	RHU81
	16	2A24-2M16	15,2	28,5	18,0	17,0	44,5	140,5	17,0	50/25										
150	12	2A30-2M12	16,7	31,5	16,0	14,0	44,5	142,5	13,2	30/15	TN120 SE*	HT45-E	B450ND-BV	RH50	B500	HT61	RH61	B600	HT81-U	RHU81
	14	2A30-2M14	16,7	31,5	18,0	16,0	44,5	146,5	15,0	30/15										
185	12	2A37-2M12	19,2	35,5	16,0	14,0	44,5	152,5	13,2	30/15	TN120 SE*	HT45-E	B450ND-BV	RH50	B500	HT61	RH61	B600	HT81-U	RHU81
	14	2A37-2M14	19,2	35,5	18,0	16,0	44,5	156,5	15,0	30/15										
240	16	2A37-2M16	19,2	35,5	19,0	17,0	44,5	158,5	17,0	30/15	TN120 SE*	HT45-E	B450ND-BV	RH50	B500	HT61	RH61	B600	HT81-U	RHU81
	12	2A48-2M12	21,1	39,0	16,0	14,0	44,5	153,5	13,2	25/5										
300	14	2A48-2M14	21,1	39,0	18,0	16,0	44,5	157,5	15,0	25/5	TN120 SE*	HT45-E	B450ND-BV	RH50	B500	HT61	RH61	B600	HT81-U	RHU81
	16	2A48-2M16	21,1	39,0	19,0	17,0	44,5	159,5	17,0	25/5										
400	12	2A60-2M12	23,7	44,0	20,0	14,0	44,5	174,0	13,2	15/5	TN120 SE*	HT45-E	B450ND-BV	RH50	B500	HT61	RH61	B600	HT81-U	RHU81
	14	2A60-2M14	23,7	44,0	22,0	16,0	44,5	178,0	15,0	20/5										
500	16	2A60-2M16	23,7	44,0	19,0	17,0	44,5	176,0	17,0	20/5	TN120 SE*	HT45-E	B450ND-BV	RH50	B500	HT61	RH61	B600	HT81-U	RHU81
	12	2A80-2M12	27,0	51,0	20,0	14,0	44,5	177,5	13,2	15/5										
630	14	2A80-2M14	27,0	51,0	22,0	16,0	44,5	181,5	15,0	10/5	TN120 SE*	HT45-E	B450ND-BV	RH50	B500	HT61	RH61	B600	HT81-U	RHU81
	16	2A80-2M16	27,0	51,0	22,0	19,0	44,5	184,5	17,0	15/5										
800	12	2A100-2M12*	30,3	56,5	20,0	14,0	44,5	178,5	13,2	10/5	TN120 SE*	HT45-E	B450ND-BV	RH50	B500	HT61	RH61	B600	HT81-U	RHU81
	14	2A100-2M14*	30,3	56,5	22,0	16,0	44,5	182,5	15,0	10/1										
1000	16	2A100-2M16*	30,3	56,5	22,0	19,0	44,5	185,5	17,0	10/1	TN120 SE*	HT45-E	B450ND-BV	RH50	B500	HT61	RH61	B600	HT81-U	RHU81
	12	2A120-2M12*	33,4	61,5	20,0	14,0	44,5	196,5	13,2	15/1										
800	14	2A120-2M14*	33,4	61,5	22,0	19,0	44,5	200,5	15,0	15/1	TN120 SE*	HT45-E	B450ND-BV	RH50	B500	HT61	RH61	B600	HT81-U	RHU81
	16	2A120-2M16*	33,4	61,5	22,0	19,0	44,5	203,5	17,0	15/1										
1000	14	2A160-2M14*	38,0	72,0	22,0	19,0	44,5	225,5	15,0	10/1	TN120 SE*	HT45-E	B450ND-BV	RH50	B500	HT61	RH61	B600	HT81-U	RHU81
	16	2A160-2M16*	38,0	72,0	24,0	19,0	44,5	227,5	17,0	10/1										
1000	12	2A200-2M12*	44,0	80,0	20,0	14,0	44,5	233,5	13,2	6/2	TN120 SE*	HT45-E	B450ND-BV	RH50	B500	HT61	RH61	B600	HT81-U	RHU81
	16	2A200-2M16*	44,0	80,0	22,0	19,0	44,5	240,5	17,0	5/1										
	20	2A200-2M20*	44,0	80,0	24,0	23,0	44,5	246,5	21,0	6/2	TN120 SE*	HT45-E	B450ND-BV	RH50	B500	HT61	RH61	B600	HT81-U	RHU81

*See page 135



2A-2M series terminals are made from high purity Copper tube with a purity greater than 99.9%, and are annealed.

They feature a double length barrel for enhanced electrical and mechanical performance in heavy duty applications.

The double hole fixing ensures greater mechanical stability even in the presence of electrodynamic stresses. The absence of an inspection hole prevents the entry of water or moisture into the crimped joint making these terminals suitable for outdoor applications.

The terminals are electrolytically Tin plated to prevent atmospheric corrosion.

Details of the appropriate crimping tools and dies are shown on pages 248 to 249.

*Not UL approved

L-M



L-M range of connectors are designed for jointing low voltage conductors.

Made of electrolytic Copper tube with a purity greater than 99.9%, having the same dimension as A-M series lugs: L-M connectors are annealed and electrolytically Tin plated.

They feature an internal taper at both ends to ease the introduction of the conductor and a central stop to ensure correct positioning.

Details of the appropriate crimping tools and dies are shown on pages 248 to 249.

THROUGH CONNECTORS

for Copper conductors

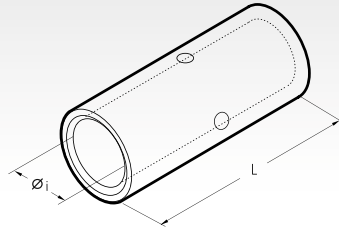

Conductor Size sqmm		Type	Dimensions mm		Quantity Box/Bag	Mechanical Tools	Hydraulic Tools
Low Stranded	Flexible		øi	L			
0,25÷1,5	0,25÷1,5	L03-M*	1,8	15	6.000/100	HN1 HN5 HN-A25 TN70SE TN120 SE* B15MD HT45-E B450ND-BV HT51 RH50 B500ND HT61 RH61 B600 HT81-U RHU81 HT120 and tools and heads with 130 kN crimping force ECW-H3D RHU520	
1,5÷2,5	1,5÷2,5	L06-M*	2,4	15	4.000/100		
4÷6	4÷6	L1-M	3,6	22	2.000/100		
10	10	L2-M	4,6	25	1.000/100		
16	16	L3-M	5,8	27	500/100		
25	25	L5-M	7,0	29	500/100		
35	25÷35	L7-M	8,9	33	400/100		
50	35÷50	L10-M	10,0	37	200/50		
70	50÷70	L14-M	11,3	39	200/50		
95	70÷95	L19-M	13,5	43	100/25		
120	95÷120	L24-M	15,2	47	75/25		
150	120÷150	L30-M	16,7	58	50/25		
185	150÷185	L37-M	19,2	64	30/15		
240	185÷240	L48-M	21,1	75	20/10		
300	240÷300	L60-M	23,7	90	20/10		
400	300÷400	L80-M	27,0	94	15/5		
500	400÷500	L100-M	30,3	98	12/1		
630	500÷630	L120-M*	33,4	105	10/1		
800	600	L160-M*	38,0	112	9/1		
1000	800	L200-M*	44,0	120	6/1		

*See page 135

L-P



Made of electrolytic Copper tube with a purity greater than 99.9%, having the same dimensions as A-M series lugs, L-P connectors are annealed and electrolytically Tin plated.

They feature an internal taper to ease the introduction of the conductor.

Details of the appropriate crimping tools and dies are shown on pages 248 to 249.

PARALLEL CONNECTORS

for Copper conductors

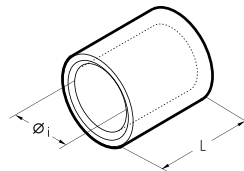

Total Conductor Size sqmm		Type	Dimensions mm		Quantity Box/Bag	Mechanical Tools	Hydraulic Tools
Low Stranded	Flexible		øi	L			
0,25÷1,5	0,25÷1,5	L03-P	1,8	6,0	8.000/100	HN1 HN5 HN-A25 TN70SE TN120 SE* B15MD HT45-E B450ND-BV HT51 RH50 B500ND HT61 RH61 B600 HT81-U RHU81 HT120 and tools and heads with 130 kN crimping force ECW-H3D RHU520	
1,5÷2,5	1,5÷2,5	L06-P	2,4	6,0	5.000/100		
4÷6	4÷6	L1-P	3,6	9,0	3.000/100		
10	10	L2-P	4,6	10,5	3.000/100		
16	16	L3-P	5,8	11,5	2.000/100		
25	25	L5-P	7,0	13,0	1.000/100		
35	25÷35	L7-P	8,9	14,0	500/100		
50	35÷50	L10-P	10,0	16,0	500/100		
70	50÷70	L14-P	11,3	18,0	500/100		
95	70÷95	L19-P	13,5	19,0	200/50		
120	95÷120	L24-P	15,2	22,0	200/50		
150	120÷150	L30-P	16,7	26,5	100/50		
185	150÷185	L37-P	19,2	26,5	100/50		
240	185÷240	L48-P	21,1	34,0	60/15		
300	240÷300	L60-P	23,7	43,0	50/25		

*See page 135

*Not UL approved

POLYAMIDE PA6.6 INSULATED COPPER TUBE LUGS

ANE-M

for Copper conductors

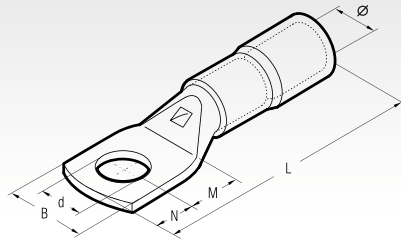

Cond. Size Flexible sqmm	Ø Stud mm	Type	Dimensions mm						Quantity Box/Bag	Mechanical Tools	Hydraulic Tools
			Ø	B	M	N	L	d			
10	4	ANE2-M4	8,0	10,0	5,0	4,0	34,1	4,3	500/100	HNN3	B15MD
	5	ANE2-M5	8,0	10,0	6,5	6,0	37,6	5,3	500/100		
	6	ANE2-M6	8,0	11,0	7,0	6,0	38,1	6,4	500/100		
	8	ANE2-M8	8,0	15,0	9,0	8,0	42,1	8,4	500/100		
	10	ANE2-M10	8,0	18,0	11,0	10,0	46,1	10,5	500/100		
16	4	ANE3-M4	9,2	11,5	5,0	4,0	38,6	4,3	400/100	HNN4	B15MD
	5	ANE3-M5	9,2	11,5	6,5	6,0	42,1	5,3	400/100		
	6	ANE3-M6	9,2	11,5	7,0	6,0	42,6	6,4	400/100		
	8	ANE3-M8	9,2	15,0	9,0	8,0	46,6	8,4	400/100		
	10	ANE3-M10	9,2	18,0	11,0	10,0	50,6	10,5	300/100		
25	4	ANE5-M4	11,1	14,0	5,0	4,0	41,0	4,3	300/100	TNN70	B15MD
	5	ANE5-M5	11,1	14,0	6,5	6,0	44,5	5,3	300/100		
	6	ANE5-M6	11,1	14,0	7,0	6,0	45,0	6,4	300/100		
	8	ANE5-M8	11,1	15,0	9,0	8,0	49,0	8,4	300/100		
	10	ANE5-M10	11,1	18,0	11,0	10,0	53,0	10,5	300/100		
35	6	ANE7-M6	13,6	17,0	7,0	6,0	50,0	6,4	100/50	TNN120	B15MD
	8	ANE7-M8	13,6	17,0	9,0	8,0	54,0	8,4	100/50		
	10	ANE7-M10	13,6	19,0	11,0	10,0	58,0	10,5	100/50		
	12	ANE7-M12	13,6	21,0	14,0	12,0	63,0	13,2	100/50		
	50	6	ANE10-M6	13,8	19,0	8,0	7,0	53,0	6,4		
8		ANE10-M8	13,8	19,0	9,0	8,0	55,0	8,4	150/50		
10		ANE10-M10	13,8	20,0	11,5	9,5	59,0	10,5	150/50		
12		ANE10-M12	13,8	21,0	12,0	12,0	62,0	13,2	150/50		
70		6	ANE14-M6	15,8	21,0	8,0	7,0	61,0	6,4	100/25	TNN120
	8	ANE14-M8	15,8	21,0	9,0	8,0	63,0	8,0	75/25		
	10	ANE14-M10	15,8	21,0	11,0	10,0	67,0	10,5	100/25		
	12	ANE14-M12	15,8	22,0	14,0	12,0	72,0	13,2	100/25		
	14	ANE14-M14	15,8	25,0	16,0	14,0	76,0	15,0	100/25		
95	8	ANE19-M8	18,0	25,0	9,0	8,0	73,0	8,4	50/25	TNN120	B15MD
	10	ANE19-M10	18,0	25,0	11,0	10,0	77,0	10,5	50/25		
	12	ANE19-M12	18,0	25,0	14,0	12,0	82,0	13,2	50/25		
	14	ANE19-M14	18,0	25,0	16,0	14,0	86,0	15,0	50/25		
	16	ANE19-M16	18,0	27,0	18,0	16,0	80,0	17,0	50/25		
120	10	ANE24-M10	20,0	28,5	11,0	10,0	77,7	10,5	50/25	TNN120	B15MD
	12	ANE24-M12	20,0	28,5	14,0	12,0	86,5	13,2	50/25		
	14	ANE24-M14	20,0	28,5	16,0	14,0	88,5	15,0	50/25		
	16	ANE24-M16	20,0	28,5	18,0	16,0	90,5	17,0	50/25		
150	12	ANE30-M12	23,0	31,5	16,0	14,0	101,0	13,2	30/15	TNN120	B15MD
	14	ANE30-M14	23,0	31,5	18,0	16,0	105,0	15,0	30/15		
	16	ANE30-M16	23,0	31,5	19,0	17,0	107,0	17,0	30/15		
	20	ANE30-M20	23,0	31,5	22,0	20,0	113,0	21,0	30/15		



ANE-M series lugs are manufactured from electrolytic Copper tube with a purity greater than 99.9%, annealed and Tin plated.

The interior of the PA6.6 insulated sleeve is funnel shaped so as to ensure complete and easy introduction of the conductor strands.

It also eliminates the need to insulate the terminal using either tape or heat shrinkable tubing.

Furthermore the PA6.6 sleeve avoids the possibility of conductor breakage at the barrel entrance.

The operating temperature range is - 20 to + 115°C (Surge + 130°C).

In order to achieve the best electrical and mechanical performance it is suggested that they are crimped using dies and tools specifically developed for this purpose by Cembre.

Details of the appropriate crimping tools and dies are shown on pages 250 to 251.

for extra flexible Copper conductors

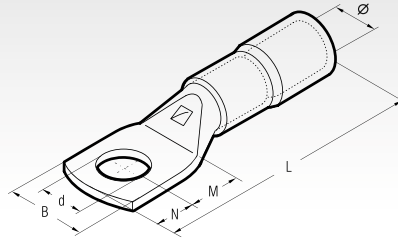

for fine stranded
SPECIAL
flexible conductors

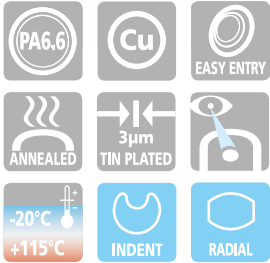

These lugs are particularly recommended for use with extra flexible conductors on for instance, welding machines.

ANE-M series lugs are manufactured from electrolytic Copper tube with a purity greater than 99.9%, annealed and Tin plated.

The interior of the PA6.6 insulated sleeve is funnel shaped so as to ensure complete and easy introduction of the conductor strands.

It also eliminates the need to insulate the terminal using either tape or heat shrinkable tubing.

Furthermore the PA6.6 sleeve avoids the possibility of conductor breakage at the barrel entrance.

The operating temperature range is - 20 to + 115°C (Surge + 130°C).

In order to achieve the best electrical and mechanical performance it is suggested that they are crimped using dies and tools specifically developed for this purpose by Cembre.

Details of the appropriate crimping tools and dies are shown on pages 250 to 251.

Conductor Size Extra Flexible sqmm	Ø Stud mm	Type	Dimensions mm						Quantity Box/Bag	Mechanical Tools	Hydraulic Tools				
			Ø	B	M	N	L	d			ECW-H3D				
35	6	ANE9-M6/15*	13,6	15,0	8,0	7,0	54,0	6,4	150/50	TNN70	B500ND	B600			
	8	ANE9-M8	13,6	17,0	9,0	8,0	56,0	8,4	150/50						
	10	ANE9-M10	13,6	18,5	11,0	10,0	60,0	10,5	150/50						
	12	ANE9-M12	13,6	21,0	14,0	12,0	65,0	13,2	150/50						
50	6	ANE12-M6/15*	15,7	15,0	8,0	7,0	59,5	6,4	50/25						
	8	ANE12-M8	15,7	19,8	9,0	8,0	61,5	8,4	50/25						
	10	ANE12-M10	15,7	19,8	11,0	10,0	65,5	10,5	50/25						
	10	ANE12-M10/19*	15,7	19,0	11,0	10,0	65,5	10,5	100/25						
70	12	ANE12-M12	15,7	22,0	14,0	12,0	70,5	13,2	50/25						
	6	ANE17-M6	17,9	23,0	8,0	7,0	63,8	6,4	100/25				TNN120	B500	B600
	8	ANE17-M8	17,9	23,0	9,0	8,0	65,8	8,4	50/25						
	10	ANE17-M10	17,9	23,0	11,0	10,0	69,8	10,5	50/25						
10	ANE17-M10/19*	17,9	19,0	11,0	10,0	69,8	10,5	100/25							
95	12	ANE17-M12	17,9	23,0	14,0	12,0	74,8	13,2	50/25						
	14	ANE17-M14	17,9	25,0	15,5	12,0	76,3	15,0	50/25						
	16	ANE17-M16	17,9	27,0	16,5	13,5	78,8	17,0	50/25						
	8	ANE20-M8	20,0	27,0	9,0	8,0	70,6	8,4	50/25						
120	10	ANE20-M10	20,0	27,0	11,0	10,0	74,6	10,5	50/25						
	12	ANE20-M12	20,0	27,0	14,0	12,0	79,6	13,2	50/25						
	14	ANE20-M14	20,0	27,0	15,5	12,0	81,1	15,0	50/25						
	16	ANE20-M16	20,0	27,0	16,5	13,5	83,6	17,0	50/25						
150	10	ANE29-M10	22,4	30,0	11,0	10,0	81,5	10,5	30/15	TNN120	B500	B600			
	12	ANE29-M12	22,4	30,0	14,0	12,0	86,5	13,2	30/15						
	14	ANE29-M14	22,4	30,0	15,5	12,0	88,5	15,0	50/25						
	16	ANE29-M16	22,4	30,0	16,5	13,5	90,5	17,0	50/25						
150	20	ANE29-M20	22,4	30,0	22,0	20,0	102,5	21,0	40/20						
	12	ANE35-M12	25,0	34,2	16,0	14,0	95,0	13,2	30/15						
	14	ANE35-M14	25,0	34,2	18,0	16,0	99,0	15,0	30/15						
	16	ANE35-M16	25,0	34,2	19,0	17,0	101,0	17,0	30/15						
20	ANE35-M20	25,0	34,2	22,0	20,0	107,0	21,0	30/15							

POLYAMIDE PA6.6 INSULATED FORK TERMINALS

for Copper conductors

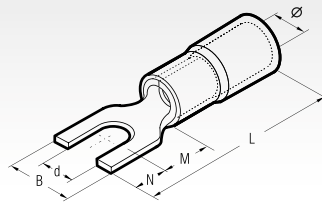

Conductor Size Flexible sqmm	Ø Stud mm	Type	Dimensions mm						Quantity Box/Bag	Mechanical Tools		Hydraulic Tools		
			Ø	B	M	N	L	d						
10	4	ANE2-U4	8,0	9,8	7,5	7,0	35,1	4,3	500/100	HN3 HN4 TN70 TN120	B15MD	HT51 RH50 B500 B500ND	B600 HT120 and tools and heads with 130 kN crimping force	ECW-H3D
	5	ANE2-U5	8,0	11,5	7,5	7,0	35,1	5,3	500/100					
16	4	ANE3-U4	9,2	10,0	10,0	8,0	41,1	4,3	400/100					
	5	ANE3-U5	9,2	11,5	10,0	8,0	41,1	5,3	400/100					

ANE-U series terminals are made from electrolytic Copper with a purity greater than 99.9%, rolled, Tin plated and brazed. The interior of the PA6.6 insulated sleeve is funnel shaped so as to ensure complete and easy introduction of the conductor strands.

The operating temperature range is – 20 to + 115°C (Surge + 130°C). In order to achieve the best electrical and mechanical performance it is suggested that they are crimped using dies and tools specifically developed for this purpose by Cembre.

Details of the appropriate crimping tools and dies are shown on pages 250 to 251.



UNINSULATED FORK TERMINALS

for Copper conductors

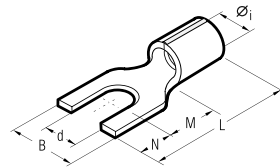

Conductor Size sqmm	Ø Stud mm	Type	Dimensions mm						Quantity Box/Bag	Mechanical Tools		Hydraulic Tools			
			Ø1	B	M	N	L	d							
10	4	A2-U4	4,8	9,8	7,5	7,0	23,5	4,3	1.500/100	HN1 HN5 TN70SE TN120SE	B15MD	HT45-E B450ND-BV	HT51 RH50 B500 B500ND	B600 HT120 and tools and heads with 130 kN crimping force	ECW-H3D
	5	A2-U5	4,8	11,5	7,5	7,0	23,5	5,3	1.500/100						
16	4	A3-U4	5,9	10,0	10,0	8,0	28,0	4,3	1.000/100						
	5	A3-U5	5,9	11,5	10,0	8,0	28,0	5,3	1.000/100						

A-U series fork terminals are designed to terminate conductors into contact blocks. Made from electrolytic Copper strip with a purity greater than 99.9%, rolled and Tin plated.

The seam is brazed to provide uniform mechanical strength. The terminal barrel is rifled to enhance electrical contact and to improve mechanical strength. Recommended crimping tools are shown on pages 248 to 249.

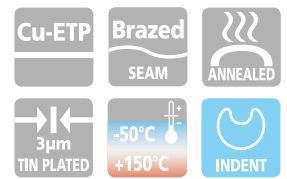

ANE-P

POLYAMIDE PA6.6 INSULATED PIN TERMINALS

for Copper conductors

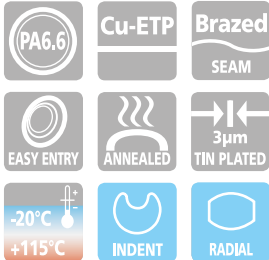
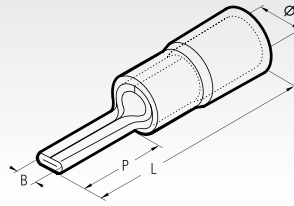

Conductor Size Flexible sqmm	Type	Dimensions mm				Quantity Box/Bag	Mechanical Tools				Hydraulic Tools			
		Ø	B	P	L		HNN3	HNN4	TNN70	TNN120	B15MD	HT51 RH50 B500ND	HT61 RH61 B600	HT120 and tools and heads with 130 kN crimping force
10	ANE2-P12	8,0	4,3	14,5	35,1	500/100								
16	ANE3-P14	9,2	5,5	18,0	41,1	400/100								
25	ANE5-P16	11,1	7,0	20,3	45,0	300/100								
35	ANE7-P20	13,6	8,0	24,5	55,0	150/50								

ANE-P series terminals are made from electrolytic Copper with a purity greater than 99.9%, rolled, Tin plated and brazed. The interior of the PA6.6 insulated sleeve is funnel shaped so as to en-

sure complete and easy introduction of the conductor strands. The operating temperature range is -20 to +115°C (Surge +130°C). In order to achieve the best electrical and mechanical performance it

is suggested that they are crimped using dies and tools specifically developed for this purpose by Cembre. Details of the appropriate crimping tools and dies are shown on pages 250 to 251.

A-P

UNINSULATED PIN CONNECTORS

for Copper conductors

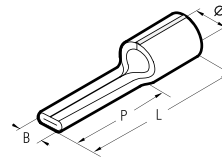

A-P series pin connectors are designed to terminate conductors into contact blocks. They are manufactured from Copper strip with a purity greater than 99.9%, rolled, brazed and Tin plated.

Details of the appropriate crimping tools and dies are shown on pages 248 to 249.

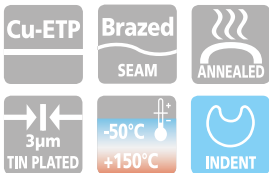

Conductor Size sqmm	Type	Dimensions mm				Quantity Box/Bag	Mechanical Tools				Hydraulic Tools					
		Low Stranded	Flex	Øi	B		P	L	HN1	HN5	HN-A25	TN70SE	TN120SE	B15MD	HT45-E B450ND-BV	HT51 RH50 B500ND
10	10 A2-P12	4,8	4,3	14,5	23,5	1.500/100										
16	16 A3-P14	5,9	5,5	18,0	28,0	1.000/100										
25	25 A5-P16	7,0	7,0	20,3	32,0	500/100										
35	25÷35 A7-P20	8,9	8,0	24,5	39,0	500/100										
50	35÷50 A10-P25	10,0	9,5	26,0	45,0	250/50										
70	50÷70 A14-P30	11,5	11,0	31,0	55,0	200/50										

A-PR

UNINSULATED ROUND PIN CONNECTORS

for Copper conductors

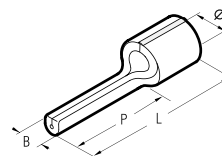

A-PR series pin connectors are designed to terminate conductors into contact blocks. They are manufactured from Copper strip with a purity greater than 99.9%, rolled, brazed and Tin plated.

Details of the appropriate crimping tools and dies are shown on pages 248 to 249.

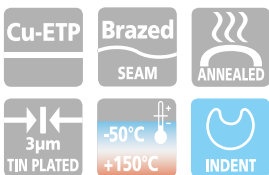

Conductor Size sqmm	Type	Dimensions mm				Quantity Box/Bag	Mechanical Tools				Hydraulic Tools					
		Low Stranded	Flex	Øi	B		P	L	HN1	HN5	HN-A25	TN70SE	TN120SE	B15MD	HT45-E B450ND-BV	HT51 RH50 B500ND
16	16 A3-P22R	5,9	4,0	22,0	32,0	1.000/100										
25	25 A5-P22R	7,0	4,0	22,0	33,7	500/100										

UNINSULATED ROUND PIN CONNECTORS ANGLED 45°

for Copper conductors

A-PR/45 series pin connectors are designed to terminate conductors into contact blocks.

They are manufactured from Copper strip with a purity greater than 99.9%, rolled, brazed and Tin plated.

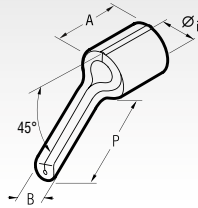

Details of the appropriate crimping tools and dies are shown on pages 248 to 249.

Conductor Size sqmm		Type	Dimensions mm				Quantity Box/Bag	Mechanical Tools		Hydraulic Tools					
Low Stranded	Flex		Øi	B	P	A		HN1	HN5	HT45-E	B450ND-BV	HT51 RH50	B500 B500ND	HT61 RH61 B600	HT120 and tools and heads with 130 kN crimping force
16	16	A3-P22R/45	5,9	4,0	22,0	10,0	1.000/100	HN-A25	TN70SE	TN120SE	B15MD				
25	25	A5-P22R/45	7,0	4,0	22,0	11,7	500/100								

A-PR/45



- Cu-ETP
- Brazed SEAM
- ANGLED 45°
- ANNEALED
- 3µm TIN PLATED
- 50°C to +150°C
- INDENT

COPPER TUBE LUGS 4-ESI FIXING

for Copper conductors

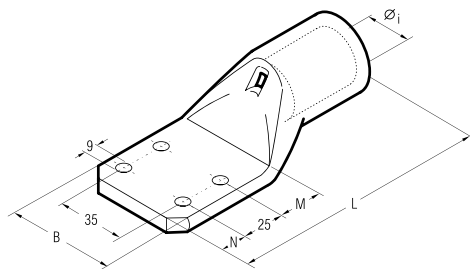

Conductor Size sqmm	Type	Dimensions mm					Quantity Box/Bag	Hydraulic Tools				ECW-H3D	RHU520
		Ø	B	M	N	L		HT51 B550	RH50 B500 B500ND	HT61 RH61 B600	HT81-U RHU81		
185	A 37-4ESI	19,2	61,0	20	15	124	20/10						
240	A 48-4ESI	21,1	61,0	20	15	128	20/10						
300	A 60-4ESI	23,7	61,0	20	15	133	15/5						
400	A 80-4ESI	27,0	61,0	20	15	134	15/5						
500	A 100-4ESI	30,3	61,0	20	15	139	10/5						
630	A 120-4ESI	33,4	61,6	20	15	144	10/5						
800	A 160-4ESI	38,0	61,0	20	15	158	8/1						

A-4ESI



- Cu
- FUNNEL ENTRY
- ANNEALED
- 3µm TIN PLATED
- HEXAGONAL
- INDENT
- "W"
- 50°C to +150°C



A-4ESI series lugs are made from electrolytic Copper tube with a purity greater than 99.9%, annealed and Tin plated.

The four hole stud fixing in accordance with E.A. specifications ensures compatibility with most transformer fixing arrangements.

Details of the appropriate crimping tools and dies are shown on pages 248 to 249.

for Copper conductors

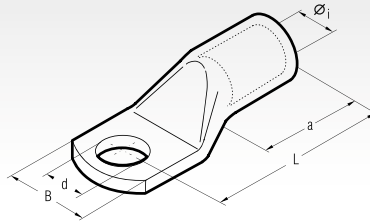

DR series lugs are manufactured from electrolytic Copper tube with a purity greater than 99.9%, and designed to obtain high electrical conductivity combined with the mechanical strength required to resist vibration and pull out.

Cembre lugs are annealed and Tin plated for improved surface protection.

The annealing process optimises the structural features of the material allowing easier crimping and greater resistance to mechanical stresses. Dimensions are according to DIN 46235.

The barrel entrance of the lug is chamfered to allow easy conductor insertion, while its length facilitates precise positioning in the crimping die.

Each lug is marked with:

- Cembre logo and part code.
- conductor type and csa (mm²).
- stud Ø (mm).
- crimping die code

Details of the appropriate crimping tools and dies are shown on page 256.

Consult us for special requirements

Conductor Size sqmm	Ø Stud mm	Type	Code	Dimensions mm					Quantity Box/Bag	Mechanical Tools	Hydraulic Tools						
				Øi	d	L	B	a									
6	5	DR6-5	5	3,8	5,3	24,0	8,5	10,0	800/100	HN-D25	B15MD						
	6	DR6-6	5	3,8	6,4	24,0	9,0	10,0	800/100								
	8	DR6-8*	5	3,8	8,4	26,0	13,0	10,0	800/100								
10	5	DR10-5	6	4,5	5,3	27,5	10,0	10,0	800/100			TND 6-70	B15MD				
	6	DR10-6	6	4,5	6,4	27,0	10,0	10,0	800/100								
	8	DR10-8*	6	4,5	8,4	28,0	13,0	10,0	800/100								
16	10	DR10-10*	6	4,5	10,5	28,5	15,0	10,0	800/100								
	6	DR16-6	8	5,5	6,4	36,0	13,0	20,0	400/100								
	8	DR16-8	8	5,5	8,4	37,0	13,0	20,0	400/100								
25	10	DR16-10	8	5,5	10,5	40,0	17,0	20,0	400/100								
	12	DR16-12*	8	5,5	13,0	41,0	19,0	20,0	400/100								
	6	DR25-6	10	7,0	6,4	39,0	14,6	20,0	400/100								
35	8	DR25-8	10	7,0	8,4	39,5	16,0	20,0	400/100								
	10	DR25-10	10	7,0	10,5	40,0	17,0	20,0	200/100								
	12	DR25-12	10	7,0	13,0	40,5	19,0	20,0	200/100								
50	6	DR35-6*	12	8,2	6,4	42,5	17,5	20,0	200/100	TND 10-120	HT45-E B450ND-BV						
	8	DR35-8	12	8,2	8,4	42,0	17,0	20,0	200/100								
	10	DR35-10	12	8,2	10,5	43,0	19,0	20,0	200/100								
70	12	DR35-12	12	8,2	13,0	43,0	21,0	20,0	200/100								
	16	DR35-16*	12	8,2	17,0	44,0	28,0	20,0	200/100								
	6	DR50-6*	14	10,0	6,4	52,0	20,0	28,0	100/25								
95	8	DR50-8	14	10,0	8,4	52,0	20,0	28,0	100/25								
	10	DR50-10	14	10,0	10,5	53,0	22,0	28,0	100/25								
	12	DR50-12	14	10,0	13,0	53,0	24,0	28,0	100/25								
120	16	DR50-16	14	10,0	17,0	57,0	28,0	28,0	100/25								
	8	DR70-8	16	11,5	8,4	56,0	24,0	28,0	50/25								
	10	DR70-10	16	11,5	10,5	56,0	24,0	28,0	50/25								
150	12	DR70-12	16	11,5	13,0	56,0	24,0	28,0	50/25								
	16	DR70-16	16	11,5	17,0	60,0	30,0	28,0	50/25								
	20	DR70-20*	16	11,5	21,0	84,5	30,0	28,0	50/25								
185	8	DR95-8*	18	13,5	8,4	65,0	28,0	35,0	50/25								
	10	DR95-10	18	13,5	10,5	66,0	28,0	35,0	50/25								
	12	DR95-12	18	13,5	13,0	66,0	28,0	35,0	50/25								
240	16	DR95-16	18	13,5	17,0	65,5	32,0	35,0	50/25								
	20	DR95-20*	18	13,5	21,0	71,0	33,0	35,0	50/25								
	8	DR120-8*	20	15,5	8,4	70,0	31,0	35,0	50/25								
280	10	DR120-10	20	15,5	10,5	70,0	32,0	35,0	50/25								
	12	DR120-12	20	15,5	13,0	70,5	32,0	35,0	50/25								
	16	DR120-16	20	15,5	17,0	70,0	32,0	35,0	50/25								
350	20	DR120-20	20	15,5	21,0	72,0	36,0	35,0	50/25								
	10	DR150-10	22	17,0	10,5	79,0	34,0	35,0	50/25								
	12	DR150-12	22	17,0	13,0	78,5	34,0	35,0	40/20								
420	16	DR150-16	22	17,0	17,0	78,0	34,0	35,0	40/20								
	20	DR150-20	22	17,0	21,0	78,0	40,0	35,0	50/25								
	10	DR185-10	25	19,0	10,5	83,0	37,0	40,0	25/25								
500	12	DR185-12	25	19,0	13,0	82,5	37,0	40,0	25/25								
	16	DR185-16	25	19,0	17,0	82,0	37,0	40,0	25/25								
	20	DR185-20	25	19,0	21,0	83,0	40,0	40,0	25/25								
630	10	DR240-10*	28	21,5	10,5	92,0	42,0	40,0	20/10								
	12	DR240-12	28	21,5	13,0	92,0	42,5	40,0	20/10								
	16	DR240-16	28	21,5	17,0	92,0	42,5	40,0	20/10								
800	20	DR240-20	28	21,5	21,0	92,0	45,0	40,0	20/10								

* Dimensions of the tube according to DIN 46235; Stud hole not included within the standard.

COPPER TUBE CRIMPING LUGS ACCORDING TO DIN 46235

for Copper conductors

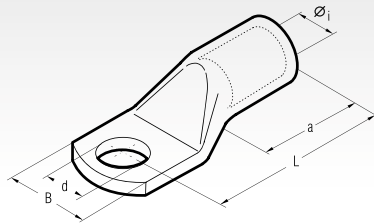

Conductor Size sqmm	Ø Stud mm	Type	Code	Dimensions mm					Quantity Box/Bag	Hydraulic Tools											
				Øi	d	L	B	a		RH50 B500 B500ND	HT120 and tools and heads with 130 kN crimping force	ECW-H3D RHU520									
300	12	DR300-12*	32	24,5	13,0	104,0	47,0	50,0	10/5				ECW-H3D RHU520								
	16	DR300-16	32	24,5	17,0	100,0	48,0	50,0	10/5												
	20	DR300-20	32	24,5	21,0	100,0	47,0	50,0	10/5												
400	12	DR400-12*	38	27,5	13,0	117,0	55,0	70,0	5/5	ECW-H3D RHU520											
	16	DR400-16	38	27,5	17,0	117,0	55,0	70,0	5/5												
	20	DR400-20	38	27,5	21,0	117,0	55,0	70,0	5/5												
500	12	DR500-12*	42	31,0	13,0	130,0	60,0	70,0	5/5							ECW-H3D RHU520					
	16	DR500-16*	42	31,0	17,0	130,0	60,0	70,0	5/5												
	20	DR500-20	42	31,0	21,0	130,0	60,0	70,0	5/5												
625	20	DR625-20	44	34,5	21,0	135,0	63,0	80,0	5/5										ECW-H3D RHU520		
800	20	DR800-20	52	40,0	21,0	166,0	75,0	100,0	5/5												
1.000	20	DR1000-20	58	44,0	21,0	166,0	85,0	100,0	5/5												

* Dimensions of the tube according to DIN 46235; Stud hole not included within the standard.

DR

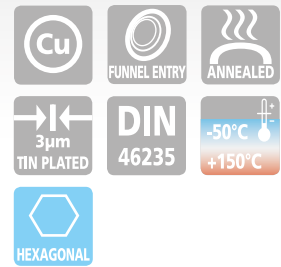

Consult us for special requirements

CRIMPING THROUGH CONNECTORS ACCORDING TO DIN 46267 T.1

for Copper conductors

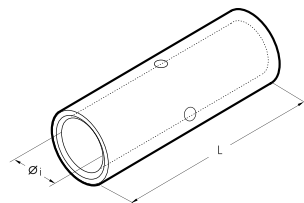

Conductor Size sqmm	Type	Code	Dimensions mm		Quantity Box/Bag	Mechanical Tools	Hydraulic Tools					
			Øi	L			HT45-E	RH50 B500 B500ND	HT61 RH61 B600	HT81-U RHU81	HT120 and tools and heads with 130 kN crimping force	ECW-H3D RHU520
6	DSV6	5	3,7	30	1.200/100	HIN-D25 TND6-70 TND10-120 B15MD						
10	DSV10	6	4,4	30	1.200/100							
16	DSV16	8	5,5	50	400/100							
25	DSV25	10	7,0	50	200/100							
35	DSV35	12	8,2	50	200/100							
50	DSV50	14	10,0	56	200/50							
70	DSV70	16	11,5	56	100/50							
95	DSV95	18	13,5	70	100/50							
120	DSV120	20	15,5	70	50/25							
150	DSV150	22	17,0	80	50/25							
185	DSV185	25	19,0	85	25/25							
240	DSV240	28	21,5	90	15/15							
300	DSV300	32	24,5	100	10/5							
400	DSV400	38	27,5	150	10/5							
500	DSV500	42	31,0	160	5/5							
625	DSV625	44	34,5	160	5/5							
800	DSV800	52	40,0	200	5/5							
1.000	DSV1000	58	44,0	200	5/5							

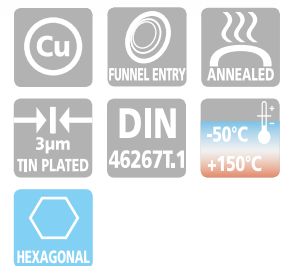

DSV series through connectors are manufactured from electrolytic Copper tube with a purity greater than 99.9%, annealed and surface protected by tin plating. Internal and external dimensions match those of DR series lugs. Chamfered ends and a central stop provide easy and correct insertion of the conductor. Details of the appropriate crimping tools and dies are shown on page 256.

Consult us for special requirements

for Copper conductors

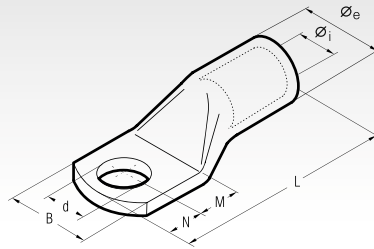

HR series lugs are manufactured from electrolytic Copper tube with a purity greater than 99.9%, and designed to obtain high electrical conductivity combined with the mechanical strength required to resist vibration and pull out.

Cembre lugs are annealed and Tin plated for improved surface protection.

The annealing process optimises the structural features of the material allowing easier crimping and greater resistance to mechanical stresses.

The barrel entrance of the lug is chamfered to allow easy conductor insertion, while its length facilitates precise positioning in the crimping die.

Each lug is marked with:

- Cembre logo and part code.
- conductor type and csa (mm²).
- stud Ø (mm).
- crimping die code

Details of the appropriate crimping tools and dies are shown on page 256.

Consult us for special requirements

Conductor Size sqmm	Ø Stud mm	Type	Dimensions mm							Quantity Box/Bag	Mechanical Tools	Hydraulic Tools
			Øi	Øe	B	M	N	L	d			
10	6	HR10-6	4,5	7,0	12,0	7,5	7,5	30,5	6,4	800/100	HN1	B15MD
	8	HR10-8	4,5	7,0	15,0	10,0	10,0	35,5	8,4	800/100		
	10	HR10-10	4,5	7,0	18,0	12,0	12,0	39,5	10,5	800/100		
	12	HR10-12	4,5	7,0	19,0	13,0	13,0	41,5	13,2	800/100		
16	5	HR16-5	5,5	8,5	12,0	6,5	6,0	30,5	5,3	400/100	HN5	B15MD
	6	HR16-6	5,5	8,5	12,0	7,5	7,5	33,0	6,4	400/100		
	8	HR16-8	5,5	8,5	15,0	10,0	10,0	38,0	8,4	400/100		
	10	HR16-10	5,5	8,5	18,0	12,0	12,0	42,0	10,5	400/100		
25	12	HR16-12	5,5	8,5	20,0	13,0	13,0	44,0	13,2	400/100	HN-H25	B15MD
	6	HR25-6	7,0	10,0	14,0	7,5	7,5	35,0	6,4	400/100		
	8	HR25-8	7,0	10,0	15,0	10,0	10,0	40,0	8,4	400/100		
	10	HR25-10	7,0	10,0	18,0	12,0	12,0	44,0	10,5	400/100		
35	12	HR25-12	7,0	10,0	20,0	13,0	13,0	46,0	13,2	400/100	HN-H25	B15MD
	14	HR25-14	7,0	10,0	21,0	14,0	14,0	48,0	15,0	400/100		
	6	HR35-6	8,5	12,0	17,0	7,5	7,5	38,5	6,4	200/50		
	8	HR35-8	8,5	12,0	17,0	10,0	10,0	43,5	8,4	200/50		
50	10	HR35-10	8,5	12,0	18,0	12,0	12,0	47,5	10,5	200/50	TNH6-70	B15MD
	12	HR35-12	8,5	12,0	21,0	13,0	13,0	49,5	13,2	200/50		
	14	HR35-14	8,5	12,0	21,0	14,0	14,0	51,5	15,0	200/50		
	16	HR35-16	8,5	12,0	26,0	16,0	16,0	57,5	17,0	200/50		
70	6	HR50-6	10,0	14,0	20,0	10,0	10,0	47,5	6,4	200/50	TNH6-70	B15MD
	8	HR50-8	10,0	14,0	20,0	10,0	10,0	47,5	8,4	200/50		
	10	HR50-10	10,0	14,0	20,0	12,0	12,0	51,5	10,5	200/50		
	12	HR50-12	10,0	14,0	21,0	13,0	13,0	53,5	13,2	200/50		
95	14	HR50-14	10,0	14,0	21,0	14,0	14,0	55,5	15,0	200/50	TNH6-70	B15MD
	16	HR50-16	10,0	14,0	26,0	18,0	16,0	61,5	17,0	100/50		
	6	HR70-6	12,0	16,5	24,0	10,0	10,0	53,0	6,4	100/25		
	8	HR70-8	12,0	16,5	24,0	10,0	10,0	53,0	8,4	100/25		
120	10	HR70-10	12,0	16,5	24,0	12,0	12,0	57,0	10,5	80/20	TNH10-120	B15MD
	12	HR70-12	12,0	16,5	24,0	13,0	13,0	59,0	13,2	80/20		
	14	HR70-14	12,0	16,5	24,0	14,0	14,0	61,0	15,0	80/20		
	16	HR70-16	12,0	16,5	30,0	18,0	16,0	67,0	17,0	60/15		
150	8	HR95-8	13,5	18,0	26,0	10,0	10,0	57,0	8,4	100/25	TNH10-120	B15MD
	10	HR95-10	13,5	18,0	26,0	12,0	12,0	61,0	10,5	100/25		
	12	HR95-12	13,5	18,0	26,0	13,0	13,0	63,0	13,2	100/25		
	14	HR95-14	13,5	18,0	26,0	14,0	14,0	65,0	15,0	100/25		
120	16	HR95-16	13,5	18,0	30,0	18,0	16,0	71,0	17,0	100/25	TNH10-120	B15MD
	20	HR95-20	13,5	18,0	36,0	22,0	21,0	80,0	21,0	100/25		
	8	HR120-8	15,0	19,5	29,0	14,0	14,0	67,5	8,4	100/25		
	10	HR120-10	15,0	19,5	29,0	14,0	14,0	67,5	10,5	100/25		
150	12	HR120-12	15,0	19,5	29,0	14,0	14,0	67,5	13,2	100/25	TNH10-120	B15MD
	14	HR120-14	15,0	19,5	29,0	15,0	15,0	69,5	15,0	100/25		
	16	HR120-16	15,0	19,5	31,0	18,0	16,0	73,5	17,0	100/25		
	20	HR120-20	15,0	19,5	36,0	22,0	21,0	82,5	21,0	50/25		
150	8	HR150-8	16,5	21,0	31,0	14,0	14,0	72,5	8,4	40/10	TNH10-120	B15MD
	10	HR150-10	16,5	21,0	31,0	14,0	14,0	72,5	10,5	40/10		
	12	HR150-12	16,5	21,0	31,0	14,0	14,0	72,5	13,2	40/10		
	14	HR150-14	16,5	21,0	31,0	15,0	15,0	74,5	15,0	40/10		
150	16	HR150-16	16,5	21,0	31,0	18,0	16,0	78,5	17,0	40/10	TNH10-120	B15MD
	20	HR150-20	16,5	21,0	36,0	22,0	21,0	87,5	21,0	60/15		

COPPER TUBE CRIMPING LUGS

for Copper conductors

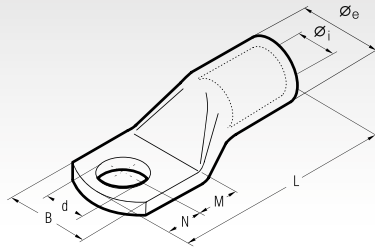

Conductor Size sqmm	Ø Stud mm	Type	Dimensions mm							Quantity Box/Bag	Hydraulic Tools			
			Øi	Øe	B	M	N	L	d		HT51	B500	B600	ECW-H3D
185	10	HR185-10	19,0	24,0	35,0	18,0	16,0	84,5	10,5	40/10	HT51 RH50 B500ND HT61 RH61 B600 HT81-U RHU81 HT120 and tools and heads with 130 kN crimping force ECW-H3D			
	12	HR185-12	19,0	24,0	35,0	18,0	16,0	84,5	13,2	40/10				
	14	HR185-14	19,0	24,0	35,0	18,0	16,0	84,5	15,0	40/10				
	16	HR185-16	19,0	24,0	35,0	18,0	16,0	84,5	17,0	40/10				
	20	HR185-20	19,0	24,0	37,0	22,0	21,0	93,5	21,0	40/10				
240	10	HR240-10	21,0	26,0	39,0	18,0	16,0	90,5	10,5	40/10				
	12	HR240-12	21,0	26,0	39,0	18,0	16,0	90,5	13,5	40/10				
	14	HR240-14	21,0	26,0	39,0	18,0	16,0	90,5	15,0	40/10				
	16	HR240-16	21,0	26,0	39,0	22,0	21,0	99,5	17,0	40/10				
	20	HR240-20	21,0	26,0	39,0	22,0	21,0	99,5	21,0	40/10				
300	12	HR300-12	23,5	29,5	44,0	18,0	16,0	99,5	13,5	10/5				
	16	HR300-16	23,5	29,5	44,0	22,0	21,0	108,5	17,0	10/5				

HR



CRIMPING THROUGH CONNECTORS

for Copper conductors

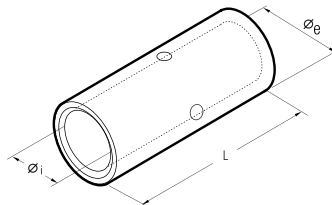

Conductor Size sqmm	Type	Dimensions mm			Quantity Box/Bag	Mechanical Tools				Hydraulic Tools			
		Øi	Øe	L		HN1	HN-5	HN-H25	TNH6-70	TNH10-120	B15MD	B450ND-BV	HT51
10	HSV10	4,5	7,0	30	1200/100	HT45-E HT51 RH50 B500ND HT61 RH61 B600 HT81-U RHU81 HT120 and tools and heads with 130 kN crimping force ECW-H3D							
16	HSV16	5,5	8,5	35	800/100								
25	HSV25	7,0	10,0	40	400/100								
35	HSV35	8,5	12,0	45	200/50								
50	HSV50	10,0	14,0	50	200/50								
70	HSV70	12,0	16,5	55	160/40								
95	HSV95	13,5	18,0	60	80/10								
120	HSV120	15,0	19,5	65	80/10								
150	HSV150	16,5	21,0	70	80/10								
185	HSV185	19,0	24,0	75	40/20								
240	HSV240	21,0	26,0	85	40/20								
300	HSV300	23,5	29,5	100	20/10								

HSV



HSV series through connectors are manufactured from electrolytic Copper tube with a purity greater than 99.9%, annealed and surface protected by tin plating. Internal and external dimensions match those of HR series lugs. Chamfered ends and a central stop provide easy and correct insertion of the conductor. Details of the appropriate crimping tools and dies are shown on page 256.

Consult us for special requirements

for Copper conductors

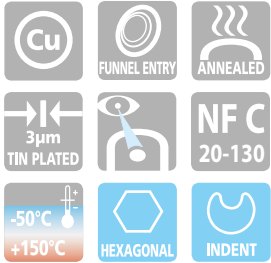
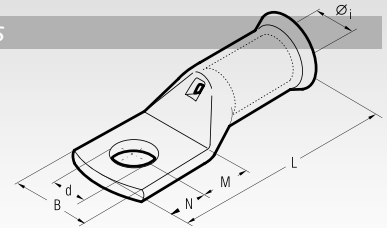

T-M series lugs are manufactured from electrolytic Copper tube with a purity greater than 99.9%.

The dimensions of the tube are designed to obtain the most efficient electrical conductivity and mechanical strength to resist vibration and pull out.

Cembre lugs are annealed to guarantee optimum ductility which is an absolute necessity for connectors which will have to withstand the severe deformation arising when compressed and any bending of the palm during installation.

In applications subject to vibration, lugs still have to provide a reliable connection and annealing plays a vital role in avoiding cracking or breaks between the barrel and palm.

The insertion of the cable is facilitated by a tulip out

The presence of an inspection hole facilitates full insertion of the conductor, whilst the barrel length has been designed to allow easy and accurate positioning of the dies during the crimping operation.

Lugs are electrolytically Tin plated to avoid oxidation.

Our technicians are always available to provide any technical advice which may be required.

The enclosed table is only indicative of the range and many variations in stud fixing and palm lengths are also available.

Details of the appropriate crimping tools and dies are shown on pages 258 to 259.

Conductor Size sqmm	Ø Stud mm	Type	Dimensions mm							Quantity Box/Bag	Mechanical Tools	Hydraulic Tools
			Øi	B	M	N	L	d				
4	4	T4-M4	2,7	9,0	7,0	6,0	27,5	4,2	1.200/100	HN1	B15MD	
	5	T4-M5	2,7	9,0	7,0	6,0	27,5	5,2	2.000/100			
	6	T4-M6	2,7	12,0	9,0	8,0	32,0	6,4	1.200/100			
4÷6	4	T6-M4	3,3	10,0	6,5	6,0	30,0	4,2	1.200/100	HN1	B15MD	
	5	T6-M5	3,3	13,0	6,5	6,0	30,0	5,2	1.200/100			
	6	T6-M6	3,3	13,0	9,0	8,0	34,5	6,4	800/100			
8	6	T6-M8	3,3	13,0	11,0	10,0	38,5	8,3	800/100	HN1	B15MD	
	5	T10-M5	4,2	11,0	6,5	6,0	30,0	5,2	800/100			
	6	T10-M6	4,2	11,0	9,0	8,0	34,5	6,4	800/100			
10	8	T10-M8	4,2	14,0	11,0	10,0	38,5	8,3	800/100	HN1	B15MD	
	10	T10-M10	4,2	14,0	14,0	12,0	43,5	10,3	800/100			
	5	T16-M5	5,3	12,0	6,5	6,0	34,0	5,2	800/100			
16	6	T16-M6	5,3	12,0	9,0	8,0	38,5	6,4	400/100	HN-T25	B15MD	
	8	T16-M8	5,3	16,0	11,0	10,0	42,5	8,3	400/100			
	10	T16-M10	5,3	16,0	14,0	12,0	47,5	10,3	400/100			
25	5	T25-M5	6,6	13,0	6,5	6,0	35,5	5,2	400/100	TN70SE	B15MD	
	6	T25-M6	6,6	13,0	9,0	8,0	40,0	6,4	400/100			
	8	T25-M8	6,6	16,0	11,0	10,0	44,0	8,3	400/100			
25	10	T25-M10	6,6	16,0	14,0	12,0	49,0	10,3	400/100	TN70SE	B15MD	
	12	T25-M12	6,6	19,0	18,0	16,0	57,0	12,8	200/50			
	6	T35-M6	7,9	15,0	9,0	8,0	41,0	6,4	200/50			
35	8	T35-M8	7,9	17,0	11,0	10,0	45,0	8,3	200/50	TN120SE	B15MD	
	10	T35-M10	7,9	17,0	14,0	12,0	50,0	10,3	200/50			
	12	T35-M12	7,9	17,0	18,0	16,0	58,0	12,8	200/50			
50	6	T50-M6	9,2	18,0	9,0	8,0	46,5	6,4	200/25	TN120SE	HT45-E B450ND-BV	
	8	T50-M8	9,2	18,0	11,0	10,0	50,5	8,3	200/25			
	10	T50-M10	9,2	18,0	14,0	12,0	55,5	10,3	200/25			
50	12	T50-M12	9,2	19,0	18,0	16,0	63,5	12,8	100/25	TN120SE	HT45-E B450ND-BV	
	8	T70-M8	11,0	21,0	11,0	10,0	54,0	8,3	100/25			
	10	T70-M10	11,0	21,0	14,0	12,0	59,0	10,3	100/25			
70	12	T70-M12	11,0	21,0	18,0	16,0	67,0	12,8	100/25	TN120SE	HT45-E B450ND-BV	
	8	T95-M8	13,1	23,0	11,0	10,0	60,0	8,3	80/20			
	10	T95-M10	13,1	23,0	14,0	12,0	65,0	10,3	80/20			
95	12	T95-M12	13,1	23,0	18,0	16,0	73,0	12,8	80/20	TN120SE	HT45-E B450ND-BV	
	14	T95-M14	13,1	23,0	18,0	16,0	73,0	14,5	80/20			
	16	T95-M16	13,1	23,0	19,0	17,0	75,0	16,5	80/20			
120	8	T120-M8	14,5	28,0	11,0	10,0	63,0	8,3	100/25	TN120SE	HT45-E B450ND-BV	
	10	T120-M10	14,5	28,0	14,0	12,0	68,0	10,3	50/25			
	12	T120-M12	14,5	28,0	18,0	16,0	76,0	12,8	50/25			
120	14	T120-M14	14,5	28,0	18,0	16,0	76,0	14,5	50/25	TN120SE	HT45-E B450ND-BV	
	16	T120-M16	14,5	28,0	19,0	17,0	78,0	16,5	50/25			
	8	T150-M8	16,2	30,0	11,0	10,0	72,5	8,3	40/10			
150	10	T150-M10	16,2	30,0	14,0	12,0	77,5	10,3	40/10	TN120SE	HT45-E B450ND-BV	
	12	T150-M12	16,2	30,0	18,0	16,0	85,5	12,8	40/10			
	14	T150-M14	16,2	30,0	18,0	16,0	85,5	14,5	40/10			
150	16	T150-M16	16,2	30,0	19,0	17,0	87,5	16,5	40/10	TN120SE	HT45-E B450ND-BV	
	10	T185-M10	18,0	33,0	14,0	12,0	83,5	10,3	40/10			
	12	T185-M12	18,0	33,0	18,0	16,0	91,5	12,8	40/10			
185	14	T185-M14	18,0	33,0	18,0	16,0	91,5	14,5	40/10	TN120SE	HT45-E B450ND-BV	
	16	T185-M16	18,0	33,0	19,0	17,0	93,5	16,5	40/10			
	10	T240-M10	20,6	37,0	13,0	11,0	87,5	10,3	20/10			
240	12	T240-M12	20,6	37,0	16,0	14,0	93,5	12,8	20/10	TN120SE	HT45-E B450ND-BV	
	14	T240-M14	20,6	37,0	18,0	16,0	97,5	14,5	20/10			
	16	T240-M16	20,6	37,0	19,0	17,0	99,5	16,5	20/10			
240	20	T240-M20	20,6	37,0	22,0	20,0	105,5	21,0	20/10	TN120SE	HT45-E B450ND-BV	
	10	T300-M10	23,1	41,0	14,0	11,0	95,0	10,3	20/5			
	12	T300-M12	23,1	41,0	20,0	14,0	104,0	12,8	20/5			
300	14	T300-M14	23,1	41,0	22,0	16,0	108,0	14,5	20/5	TN120SE	HT45-E B450ND-BV	
	16	T300-M16	23,1	41,0	22,0	19,0	111,0	16,5	20/5			
	20	T300-M20	23,1	41,0	24,0	23,0	117,0	21,0	10/5			
400	14	T400-M14	26,1	47,0	22,0	19,0	119,0	14,5	10/5	TN120SE	HT45-E B450ND-BV	
	16	T400-M16	26,1	47,0	22,0	19,0	119,0	16,5	10/5			
	20	T400-M20	26,1	47,0	24,0	23,0	125,0	21,0	10/5			

COPPER TUBE CRIMPING LUGS ANGLED 90°

for Copper conductors

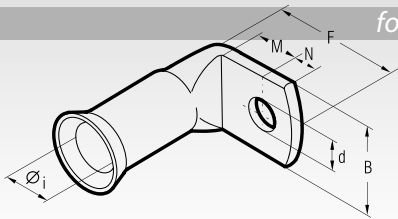

Conductor Size sqmm	Stud mm	Type	Dimensions mm							Quantity Box/Bag	Mechanical Tools	Hydraulic Tools
			Øi	B	M	N	F*	d				
4÷6	6	T6-L6	3,3	13,0	9,0	8,0	23,6	6,4	800/100	HNI	B15MD	
	5	T10-L5	4,2	11,0	6,0	6,0	20,3	5,2	800/100			
10	6	T10-L6	4,2	11,0	8,0	8,0	24,8	6,4	800/100	HNS	B15MD	
	8	T10-L8	4,2	14,0	11,0	10,0	28,8	8,3	800/100			
16	6	T16-L6	5,3	12,0	9,0	8,0	26,5	6,4	400/100	HN-T25	B15MD	
	8	T16-L8	5,3	16,0	11,0	10,0	30,5	8,3	400/100			
25	6	T25-L6	6,6	13,0	9,0	8,0	28,0	6,4	400/100	TN70SE	B15MD	
	8	T25-L8	6,6	16,0	11,0	10,0	32,0	8,3	400/100			
35	6	T35-L6	7,9	15,0	9,0	8,0	29,5	6,4	400/50	TN120SE	B15MD	
	8	T35-L8	7,9	17,0	11,0	10,0	33,5	8,3	200/50			
50	6	T50-L6	9,2	18,0	9,0	8,0	31,5	6,4	100/25	TN120SE	B15MD	
	8	T50-L8	9,2	18,0	10,0	10,0	35,5	8,3	200/25			
70	10	T70-L10	11,0	21,0	14,0	12,0	43,5	10,3	100/25	TN120SE	B15MD	
	12	T70-L12	11,0	21,0	18,0	16,0	51,5	12,8	100/25			
95	8	T95-L8	13,1	23,0	11,0	10,0	41,0	8,3	100/25	TN120SE	B15MD	
	10	T95-L10	13,1	23,0	14,0	12,0	46,0	10,3	100/25			
120	12	T95-L12	13,1	23,0	18,0	16,0	54,0	12,8	100/25	TN120SE	B15MD	
	10	T120-L10	14,5	28,0	14,0	12,0	48,0	10,3	50/25			
150	12	T120-L12	14,5	28,0	18,0	16,0	56,0	12,8	50/25	TN120SE	B15MD	
	10	T150-L10	16,2	30,0	14,0	12,0	50,0	10,3	40/10			
185	12	T150-L12	16,2	30,0	18,0	16,0	58,0	12,8	40/10	TN120SE	B15MD	
	10	T185-L10	18,0	33,0	14,0	12,0	52,0	10,3	40/10			

T-L

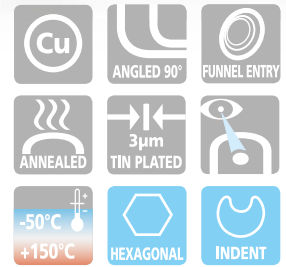

T-L series lugs angled 90° are manufactured from electrolytic Copper tube with a purity greater than 99.9%.

T-L series lugs having the same dimensions and characteristics as T-M series lugs.

F* = indicative dimension

Details of the appropriate crimping tools and dies are shown on pages 258 to 259.

CRIMPING THROUGH CONNECTORS

for Copper conductors

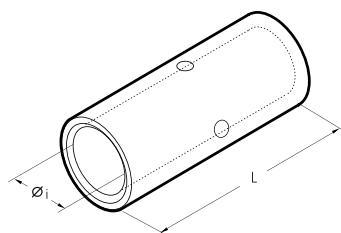

Total Conductor Size sqmm		Type	Dimensions mm		Quantity Box/Bag	Mechanical Tools	Hydraulic Tools
Low Stranded	Flexible		Øi	L			
4	4	L4-T	2,7	22	2.000/100	HNI	B15MD
4÷6	4÷6	L6-T	3,3	25	1.500/100		
10	10	L10-T	4,2	27	1.000/100	HNS	B15MD
16	16	L16-T	5,3	31	500/100		
25	25	L25-T	6,6	35	500/100	HN-A25	B15MD
35	25	L35-T	7,9	37	250/50		
50	35	L50-T	9,2	45	250/50	TN70SE	B15MD
70	50	L70-T	11,0	50	200/50		
95	70	L95-T	13,1	56	100/25	TN120SE	B15MD
120	95	L120-T	14,5	60	100/25		
150	120	L150-T	16,2	66	50/25	TN120SE	B15MD
185	150	L185-T	18,0	75	50/25		
240	185	L240-T	20,6	80	30/15	TN120SE	B15MD
300	240	L300-T	23,1	90	20/10		
400	300	L400-T	26,1	100	20/5	TN120SE	B15MD

L-T



Made of electrolytic Copper tube with a purity greater than 99.9%, having the same dimensions as T-M series lugs, L-T connectors are annealed and electrolytically Tin plated.

They feature an internal taper to ease the introduction of the conductor. Details of the appropriate crimping tools and dies are shown on pages 258 to 259.

for Copper conductors

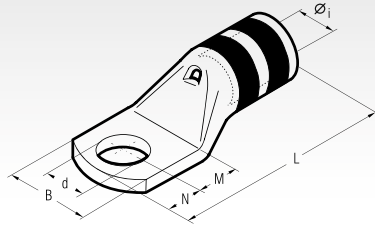

C series lugs are manufactured from electrolytic Copper tube with a purity greater than 99.9%.

The dimensions of the tube are designed to obtain the most efficient electrical conductivity and mechanical strength to resist vibration and pull out.

Cembre lugs are annealed to guarantee optimum ductility, an absolute necessity for connectors which will have to withstand the severe deformation arising when compressed and any bending of the palm during installation.

In applications subject to vibration, terminals have to perform a reliable connection, the annealing process plays a vital role in avoiding cracking or breaks between the barrel and palm.

The presence of an inspection hole facilitates full insertion of the conductor. The barrel length has been designed to allow easy and accurate positioning of the dies during the crimping operation.

Lugs are electrolytically Tin plated to avoid oxidation.

The tongue is clearly marked with wire size and die index for Cembre tools.

UL listed for US and Canada per UL486A up to 35 KV.

C series lugs are an important part of Cembre crimping systems for power carrying conductors.

Details of the appropriate crimping tools and dies are shown on page 257.

Cembre technicians are available to provide technical advice as required. Please consult Cembre for products not listed.

Cond. Size sqmm	Conductor AWG		Ø Stud mm	Type	Dimensions mm					Colour Code	Quantity Box/Bag	Mechanical Tools	Hydraulic Tools
	Size	Navy			Øi	B	M	N	L				
10	8	23	4	C8-8	4,6	10,0	5,0	4,0	22,5	4,3	RED	600/50	B15MD
			5	C8-10	4,6	10,0	6,5	6,0	26,0	5,3		600/50	
			6	C8-14	4,6	11,0	7,0	6,0	26,5	6,4		600/50	
			8	C8-516	4,6	15,0	9,0	8,0	30,5	8,4		600/50	
			10	C8-38	4,6	18,0	11,0	10,0	34,5	10,5		600/50	
			12	C8-12	4,6	19,0	14,0	12,0	39,5	13,2		600/50	
16	6	40	4	C6-8	5,8	11,5	5,0	4,0	25,5	4,3	BLUE	600/50	B15MD
			5	C6-10	5,8	11,5	6,5	6,0	29,0	5,3		600/50	
			6	C6-14	5,8	11,5	7,0	6,0	29,5	6,4		600/50	
			8	C6-516	5,8	15,0	9,0	8,0	33,5	8,4		600/50	
			10	C6-38	5,8	18,0	11,0	10,0	37,5	10,5		600/50	
			12	C6-12	5,8	20,0	14,0	12,0	43,5	13,2		400/50	
25	4	40	4	C4-8	6,2	12,5	5,0	4,0	25,5	4,3	GREY	600/50	B15MD
			5	C4-10	6,2	12,5	6,5	6,0	29,0	5,3		600/50	
			6	C4-14	6,2	12,5	7,0	6,0	29,5	6,4		600/50	
			8	C4-516	6,2	15,0	9,0	8,0	33,5	8,4		600/50	
			10	C4-38	6,2	18,0	11,0	10,0	37,5	10,5		400/50	
			12	C4-12	6,2	20,0	14,0	12,0	42,5	13,2		400/50	
35	2	60	4	C3-8	7,0	14,0	5,0	4,0	28,0	4,3	WHITE	600/50	B15MD
			5	C3-10	7,0	14,0	6,5	6,0	31,5	5,3		600/50	
			6	C3-14	7,0	14,0	7,0	6,0	32,0	6,4		600/50	
			8	C3-516	7,0	15,0	9,0	8,0	36,0	8,4		600/50	
			10	C3-38	7,0	18,0	11,0	10,0	40,0	10,5		400/50	
			12	C3-12	7,0	21,0	14,0	12,0	45,0	13,2		400/50	
50	1/0	100	5	C2-10	7,6	17,0	6,5	6,0	33,0	5,3	BROWN	400/50	B15MD
			6	C2-14	7,6	17,0	7,0	6,0	33,5	6,4		400/50	
			8	C2-516	7,6	17,0	9,0	8,0	37,5	8,4		400/50	
			10	C2-38	7,6	19,0	11,0	10,0	41,5	10,5		400/50	
			12	C2-12	7,6	21,0	14,0	12,0	46,5	13,2		200/50	
			6	C1-14	8,9	17,0	7,0	6,0	34,5	6,4		400/50	
70	2/0	125	8	C1-516	8,9	17,0	9,0	8,0	38,5	8,4	GREEN	400/50	B15MD
			10	C1-38	8,9	19,0	11,0	10,0	42,5	10,5		200/50	
			12	C1-12	8,9	21,0	14,0	12,0	47,5	13,2		200/50	
			6	C1/0-14	10,0	19,0	8,0	7,0	40,5	6,4		200/25	
			8	C1/0-516	10,0	19,0	9,0	8,0	42,5	8,4		200/25	
			10	C1/0-38	10,0	20,0	11,0	10,0	46,5	10,5		200/25	
95	3/0	150	12	C1/0-12	10,0	21,0	14,0	12,0	51,5	13,2	PINK	200/25	B15MD
			14	C1/0-916	10,0	25,0	16,0	14,0	55,5	15,0		200/25	
			16	C1/0-58	10,0	26,0	18,0	16,0	59,5	17,0		200/25	
			6	C2/0-14	11,3	21,0	8,0	7,0	44,0	6,4		200/25	
			8	C2/0-516	11,3	21,0	9,0	8,0	46,0	8,4		200/25	
			10	C2/0-38	11,3	21,0	11,0	10,0	50,0	10,5		200/25	
120	4/0	200	12	C2/0-12	11,3	22,0	14,0	12,0	55,0	13,2	BLACK	200/25	B15MD
			14	C2/0-916	11,3	25,0	16,0	14,0	59,0	15,0		100/25	
			16	C2/0-58	11,3	26,0	18,0	16,0	63,0	17,0		100/25	
			20	C2/0-34	11,3	29,5	22,0	20,0	75,0	21,0		100/25	
			6	C3/0-14	12,4	23,0	8,0	7,0	45,0	6,4		200/25	
			8	C3/0-516	12,4	23,0	9,0	8,0	47,0	8,4		100/25	
150	5/0	250	10	C3/0-38	12,4	23,0	11,0	10,0	51,0	10,5	ORANGE	100/25	B15MD
			12	C3/0-12	12,4	24,0	14,0	12,0	56,0	13,2		100/25	
			14	C3/0-916	12,4	27,0	16,0	14,0	60,0	15,0		100/25	
			16	C3/0-58	12,4	28,0	18,0	16,0	64,0	17,0		100/25	
			20	C3/0-34	12,4	31,5	22,0	20,0	72,0	21,0		100/25	

COLOUR CODED COPPER CRIMPING LUGS

for Copper conductors

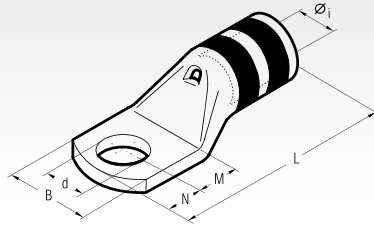

Cond. Size sqmm	Sez. Cond. AWG		Ø Stud mm	Type	Dimensions mm						Colour Code	Quantity Box/Bag	Mechanical Tools	Hydraulic Tools		
	Size	Navy			Øi	B	M	N	L	d				HT120	HT120 and tools and heads with 130 kN crimping force	
4/0	200	200	6	C4/0-14	13,5	25,0	8,0	7,0	50,5	6,4	PURPLE	100/25	TNI20SE	HT51 RH50 B500ND	ECW-HBD	RHU520
			8	C4/0-516	13,5	25,0	9,0	8,0	52,5	8,4		100/25				
			10	C4/0-38	13,5	25,0	11,0	10,0	56,5	10,5		100/25				
			12	C4/0-12	13,5	25,0	14,0	12,0	61,5	13,2		100/25				
			14	C4/0-916	13,5	25,0	16,0	14,0	65,5	15,0		100/25				
			16	C4/0-58	13,5	27,0	18,0	16,0	69,5	17,0		50/25				
120	250	250	6	C250-14	15,2	28,5	8,0	7,0	52,0	6,4	YELLOW	100/25	TNI20SE	HT51 RH50 B500ND	ECW-HBD	RHU520
			8	C250-516	15,2	28,5	9,0	8,0	54,0	8,4		100/25				
			10	C250-38	15,2	28,5	11,0	10,0	58,0	10,5		100/25				
			12	C250-12	15,2	28,5	14,0	12,0	63,0	13,2		50/25				
			14	C250-916	15,2	28,5	16,0	14,0	67,0	15,0		50/25				
			16	C250-58	15,2	28,5	18,0	16,0	71,0	17,0		50/25				
150	300	300	6	C300-14	15,2	30,0	22,0	20,0	79,0	21,0	WHITE	50/25	TNI20SE	HT51 RH50 B500ND	ECW-HBD	RHU520
			8	C300-516	16,7	31,5	13,0	11,0	69,0	8,4		40/10				
			10	C300-38	16,7	31,5	13,0	11,0	69,0	10,5		40/10				
			12	C300-12	16,7	31,5	16,0	14,0	75,0	13,2		40/10				
			14	C300-916	16,7	31,5	18,0	16,0	79,0	15,0		40/10				
			16	C300-58	16,7	31,5	19,0	17,0	81,0	17,0		40/10				
185	350	350	6	C300-34	16,7	31,5	22,0	20,0	87,0	21,0	RED	40/10	TNI20SE	HT51 RH50 B500ND	ECW-HBD	RHU520
			8	C300-78	16,7	31,5	24,0	23,0	92,0	23,0		40/10				
			10	C350-38	17,6	33,0	13,0	11,0	70,5	10,5		40/20				
			12	C350-12	17,6	33,0	16,0	14,0	76,5	13,2		40/20				
			14	C350-916	17,6	33,0	18,0	16,0	80,5	15,0		40/20				
			16	C350-58	17,6	33,0	19,0	17,0	82,5	17,0		40/20				
400	400	400	6	C350-34	17,6	33,0	22,0	20,0	88,5	21,0	BLUE	40/20	TNI20SE	HT51 RH50 B500ND	ECW-HBD	RHU520
			8	C350-78	17,6	33,0	24,0	23,0	93,5	23,0		30/15				
			10	C400-38	19,2	35,5	13,0	11,0	76,0	10,5		40/20				
			12	C400-12	19,2	35,5	16,0	14,0	82,0	13,2		40/20				
			14	C400-916	19,2	35,5	18,0	16,0	86,0	15,0		40/20				
			16	C400-58	19,2	35,5	19,0	17,0	88,0	17,0		40/20				
240	500	500	6	C400-34	19,2	35,5	22,0	20,0	94,0	21,0	BROWN	40/20	TNI20SE	HT51 RH50 B500ND	ECW-HBD	RHU520
			8	C400-78	19,2	35,5	24,0	23,0	99,0	23,0		40/20				
			10	C500-38	21,1	39,0	13,0	11,0	82,0	10,5		30/15				
			12	C500-12	21,1	39,0	16,0	14,0	88,0	13,2		30/15				
			14	C500-916	21,1	39,0	18,0	16,0	92,0	15,0		30/15				
			16	C500-58	21,1	39,0	19,0	17,0	94,0	17,0		30/15				
300	600	600	6	C500-34	21,1	39,0	22,0	20,0	100,0	21,0	GREEN	20/10	TNI20SE	HT51 RH50 B500ND	ECW-HBD	RHU520
			8	C500-78	21,1	39,0	24,0	23,0	105,0	23,0		20/10				
			12	C600-12	23,7	44,0	20,0	14,0	99,0	13,2		20/10				
			14	C600-916	23,7	44,0	22,0	16,0	103,0	15,0		20/10				
			16	C600-58	23,7	44,0	22,0	19,0	106,0	17,0		20/10				
			20	C600-34	23,7	44,0	24,0	23,0	112	21,0		10/5				
750	MCM	750	6	C600-78	23,7	44,0	24,0	23,0	112,0	23,0	BLACK	10/5	TNI20SE	HT51 RH50 B500ND	ECW-HBD	RHU520
			12	C750-12	26,0	48,0	22,0	19,0	113,0	13,2		10/5				
			16	C750-58	26,0	48,0	22,0	19,0	113,0	17,0		10/5				
			20	C750-34	26,0	48,0	24,0	23,0	119,0	21,0		10/5				
22	C750-78	26,0	48,0	24,0	23,0	119,0	23,0	10/5								

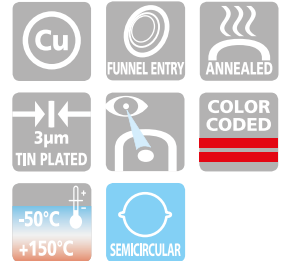

one hole long barrel - for Copper conductors

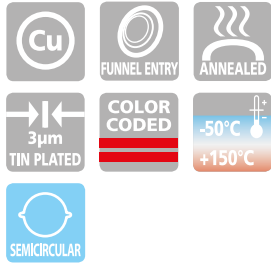
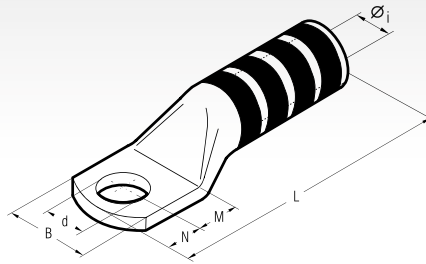

CL series lugs are manufactured from electrolytic Copper tube with a purity greater than 99.9%, for use in heavy duty applications.

The dimensions of the tube are designed to obtain the most efficient electrical conductivity and mechanical strength to resist vibration and pull out.

Cembre lugs are annealed to guarantee optimum ductility which is an absolute necessity for connectors which will have to withstand the severe deformation arising when compressed and any bending of the palm during installation.

In applications subject to vibration, terminals have to perform a reliable connection, the annealing process plays a vital role in avoiding cracking or breaks between the barrel and palm.

The long barrel provides better mechanical pull-out strength. Lugs are electrolytically Tin plated to avoid oxidation.

The tongue is clearly marked with wire size and die index for Cembre tools.

UL listed for US and Canada per UL486A up to 35 KV.

CL series lugs are an important part of Cembre crimping systems for power carrying conductors.

Details of the appropriate crimping tools and dies are shown on page 257.

Cembre technicians are available to provide technical advice as required. Please consult Cembre for products not listed.

Cond. Size sqmm	Conductor AWG	Ø Stud mm	Type	Dimensions mm						Colour Code	Quantity Box/Bag	Mechanical Tools	Hydraulic Tools								
				Øi	B	M	N	L	d												
10	8	23	5 CL8-10	4,6	10,0	6,5	6,0	37,5	5,3	RED	400/50	TN70SE	B15MD								
			6 CL8-14	4,6	11,0	7,0	6,0	38,0	6,4	RED	400/50										
			10 CL8-38	4,6	18,0	11,0	10,0	46,0	10,5	RED	400/50										
16	6	40	5 CL6-10	5,8	11,5	6,5	6,0	40,0	5,3	BLUE	400/50			TN120SE	B15MD						
			6 CL6-14	5,8	11,5	7,0	6,0	40,5	6,4	BLUE	400/50										
			12 CL6-12	5,8	20,0	14,0	12,0	53,5	13,2	BLUE	400/50										
25	4	40	5 CL4-10	6,2	12,5	6,5	6,0	47,0	5,3	GREY	400/50					TN120SE	B15MD				
			6 CL4-14	6,2	12,5	7,0	6,0	47,5	6,4	GREY	400/50										
			10 CL4-38	6,2	18,0	11,0	10,0	55,5	10,5	GREY	400/50										
			12 CL4-12	6,2	20,0	14,0	12,0	60,5	13,2	GREY	400/50										
35	2	60	6 CL3-14	7,0	14,0	7,0	6,0	47,5	6,4	WHITE	200/100							TN120SE	B15MD		
			8 CL3-516	7,0	15,0	9,0	8,0	51,5	8,4	WHITE	200/100										
			10 CL3-38	7,0	18,0	11,0	10,0	55,5	10,5	WHITE	200/100										
			12 CL3-12	7,0	21,0	14,0	12,0	60,5	13,2	WHITE	200/100										
50	1/0	100	5 CL2-10	7,6	17,0	6,5	6,0	46,0	5,3	BROWN	200/50	TN120SE	B15MD								
			6 CL2-14	7,6	17,0	7,0	6,0	46,5	6,4	BROWN	200/50										
			8 CL2-516	7,6	17,0	9,0	8,0	50,5	8,4	BROWN	200/50										
			12 CL2-12	7,6	21,0	14,0	12,0	59,5	13,2	BROWN	200/50										
70	2/0	125	5 CL1-10	8,9	17,0	6,5	6,0	48,0	5,3	GREEN	200/50			TN120SE	B15MD						
			8 CL1-516	8,9	17,0	9,0	8,0	52,5	8,4	GREEN	200/50										
			12 CL1-12	8,9	21,0	14,0	12,0	61,5	13,2	GREEN	200/50										
95	3/0	150	5 CL1/0-10	10,0	19,0	8,0	7,0	53,5	5,3	PINK	100/50					TN120SE	B15MD				
			8 CL1/0-516	10,0	19,0	9,0	8,0	55,5	8,4	PINK	100/50										
			10 CL1/0-38	10,0	20,0	11,0	10,0	59,5	10,5	PINK	100/50										
120	250 MCM	250	12 CL1/0-12	10,0	21,0	14,0	12,0	64,5	13,2	BLACK	100/50							TN120SE	B15MD		
			10 CL2/0-38	11,3	21,0	11,0	10,0	67,5	10,5	BLACK	100/50										
			12 CL2/0-12	11,3	22,0	14,0	12,0	72,5	13,2	BLACK	100/50										
150	300 MCM	300	12 CL3/0-12	12,4	24,0	14,0	12,0	71,5	13,2	ORANGE	100/50	TN120SE	B15MD								
			10 CL4/0-38	13,5	25,0	11,0	10,0	73,5	10,5	PURPLE	60/30										
185	350 MCM	350	12 CL4/0-12	13,5	25,0	14,0	12,0	78,5	13,2	PURPLE	60/30									TN120SE	B15MD
			12 CL250-12	15,2	28,5	14,0	12,0	84,0	13,2	YELLOW	50/25										
240	500 MCM	400	12 CL300-12	16,7	31,5	16,0	14,0	98,0	13,2	WHITE	30/15			TN120SE	B15MD						
			12 CL400-12	19,2	35,5	16,0	14,0	107,0	13,2	BLUE	20/10										
			16 CL400-58	19,2	35,5	19,0	17,0	113,0	17,0	BLUE	20/10										
300	600 MCM	400	12 CL500-12	21,1	39,0	16,0	14,0	108,0	13,2	BROWN	20/10					TN120SE	B15MD				
			16 CL500-58	21,1	39,0	19,0	17,0	114,0	17,0	BROWN	20/10										
300	750 MCM	400	12 CL600-12	23,7	44,0	20,0	14,0	128,5	13,2	GREEN	10/5							TN120SE	B15MD		
			16 CL600-58	23,7	44,0	22,0	19,0	135,5	17,0	GREEN	10/5										
			12 CL750-12	26,0	48,0	22,0	19,0	140,5	13,2	BLACK	10/5										
300	750 MCM	400	16 CL750-58	26,0	48,0	22,0	19,0	140,5	17,0	BLACK	10/5	TN120SE	B15MD								

Also available with inspection hole.
In case of order, add suffix IH to the part number.
E.g.: CL250IH-12

COLOUR CODED COPPER CRIMPING LUGS

CL-D

double hole long barrel - for Copper conductors

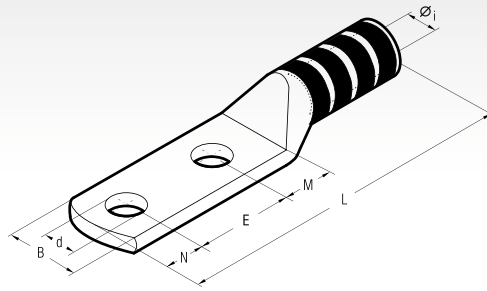

Cond. Size sqmm	Conductor AWG		Ø Stud mm	Type	Dimensions mm						Colour Code	Quantity Box/Bag	Mechanical Tools	Hydraulic Tools						
	Size	Navy			Øi	B	M	E	N	L					d					
10	8	23	6 CL8-D14	4,6	11,0	7,0	16,0	6,0	53,0	6,4	RED	400/50	B15MD							
			6 CL8-D141	4,6	11,0	7,0	19,0	6,0	56,0	6,4	RED	400/50								
			10 CL8-D38	4,6	18,0	11,0	25,5	10,0	70,5	10,5	RED	400/50								
16	6	40	6 CL6-D14	5,8	11,5	7,0	16,0	6,0	54,5	6,4	BLUE	400/50			B15MD					
			6 CL6-D141	5,8	11,5	7,0	19,0	6,0	57,5	6,4	BLUE	400/50								
			10 CL6-D38	5,8	18,0	11,0	25,5	10,0	72,0	10,5	BLUE	400/50								
25	4	60	12 CL6-DN	5,8	20,0	14,0	44,5	12,0	96,0	13,2	BLUE	400/50					B15MD			
			6 CL4-D14	6,2	12,5	7,0	16,0	6,0	62,0	6,4	GREY	200/50								
			6 CL4-D141	6,2	12,5	7,0	19,0	6,0	65,0	6,4	GREY	200/50								
35	2	100	10 CL4-D38	6,2	18,0	11,0	25,5	10,0	79,5	10,5	GREY	200/50							B15MD	
			12 CL4-DN	6,2	20,0	14,0	44,5	12,0	103,5	13,2	GREY	200/50								
			10 CL3-D38	7,0	18,0	11,0	25,5	10,0	79,5	10,5	WHITE	200/50								
50	1/0	125	12 CL3-DN	7,0	21,0	14,0	44,5	12,0	103,5	13,2	WHITE	200/50	B15MD							
			6 CL2-D14	7,6	17,0	7,0	16,0	6,0	61,0	6,4	BROWN	200/50								
			6 CL2-D141	7,6	17,0	7,0	19,0	6,0	64,0	6,4	BROWN	200/50								
70	2/0	200	10 CL2-D38	7,6	19,0	11,0	25,5	10,0	78,5	10,5	BROWN	100/50			B15MD					
			12 CL2-DN38	7,6	19,0	11,0	44,5	10,0	97,5	10,5	BROWN	100/50								
			6 CL2-DN	7,6	21,0	14,0	44,5	12,0	102,5	13,2	BROWN	100/50								
95	3/0	300	10 CL1-D14	8,9	17,0	7,0	16,0	6,0	63,0	6,4	GREEN	200/50					B15MD			
			6 CL1-D141	8,9	17,0	7,0	19,0	6,0	66,0	6,4	GREEN	200/50								
			10 CL1-D38	8,9	19,0	11,0	25,5	10,0	80,5	10,5	GREEN	100/25								
120	MCM	400	12 CL1-DN	8,9	21,0	14,0	44,5	12,0	104,5	13,2	GREEN	100/25							B15MD	
			6 CL1/0-D14	10,0	19,0	7,9	16,0	7,0	68,0	6,4	PINK	100/25								
			6 CL1/0-D141	10,0	19,0	7,9	19,0	7,0	71,0	6,4	PINK	100/25								
150	MCM	600	10 CL1/0-D38	10,0	20,0	10,9	25,5	10,0	83,5	10,5	PINK	100/25	B15MD							
			12 CL1/0-DN	10,0	21,0	14,0	44,5	12,0	107,5	13,2	PINK	100/25								
			6 CL2/0-D14	11,3	21,0	7,8	16,0	7,0	76,0	6,4	BLACK	60/30								
185	MCM	800	6 CL2/0-D141	11,3	21,0	7,8	19,0	7,0	79,0	6,4	BLACK	60/30			B15MD					
			10 CL2/0-D38	11,3	21,0	11,0	25,5	10,0	91,5	10,5	BLACK	60/30								
			12 CL2/0-DN	11,3	22,0	14,0	44,5	12,0	115,5	13,2	BLACK	60/30								
240	MCM	1000	6 CL3/0-D141	12,4	23,3	8,0	19,0	7,0	82,0	6,4	ORANGE	60/30					B15MD			
			10 CL3/0-D38	12,4	23,3	11,0	25,5	10,0	94,5	10,5	ORANGE	60/30								
			12 CL3/0-DN	12,4	24,0	14,0	44,5	12,0	118,5	13,2	ORANGE	60/30								
300	MCM	1250	6 CL4/0-D141	13,5	25,0	13,0	19,0	11,0	94,0	6,4	PURPLE	50/25							B15MD	
			10 CL4/0-D38	13,5	25,0	11,0	25,5	10,0	97,5	10,5	PURPLE	50/25								
			10 CL4/0-DN38	13,5	25,0	11,0	44,5	10,0	116,5	10,5	PURPLE	50/25								
360	MCM	1500	12 CL4/0-DN	13,5	25,0	14,0	44,5	12,0	121,5	13,2	PURPLE	50/25	B15MD							
			10 CL250-D38	15,2	28,5	11,0	25,5	10,0	103,0	10,5	YELLOW	40/20								
			12 CL250-DN	15,2	28,5	14,0	44,5	12,0	127,0	13,2	YELLOW	40/20								
450	MCM	2000	10 CL300-D38	16,7	31,5	13,0	25,5	11,0	116,0	10,5	WHITE	30/15			B15MD					
			12 CL300-DN	16,7	31,5	16,0	44,5	14,0	141,0	13,2	WHITE	30/15								
			6 CL350-D141	17,6	33,0	13,0	19,0	11,0	109,5	6,4	RED	30/15								
600	MCM	2500	10 CL350-D38	17,6	33,0	13,0	25,5	11,0	116,0	10,5	RED	30/15					B15MD			
			12 CL350-DN	17,6	33,0	16,0	44,5	14,0	141,0	13,2	RED	30/15								
			6 CL400-D141	19,2	35,5	13,0	19,0	11,0	118,5	6,4	BLUE	20/10								
800	MCM	3000	10 CL400-D38	19,2	35,5	13,0	25,5	11,0	125,0	10,5	BLUE	20/10							B15MD	
			12 CL400-DN	19,2	35,5	16,0	44,5	14,0	150,0	13,2	BLUE	20/10								
			6 CL500-D141	21,1	39,0	13,0	19,0	11,0	119,5	6,4	BROWN	20/10								
1000	MCM	3500	10 CL500-D38	21,1	39,0	13,0	25,5	11,0	126,0	10,5	BROWN	10/5	B15MD							
			12 CL500-DN	21,1	39,0	16,0	44,5	14,0	151,0	13,2	BROWN	10/5								
			10 CL600-D38	23,7	44,0	20,0	25,5	11,0	149,5	10,5	GREEN	20/5								
1250	MCM	4000	12 CL600-DN	23,7	44,0	20,0	44,5	14,0	171,5	13,2	GREEN	20/5			B15MD					
			10 CL750-DN38	26,0	48,0	20,0	44,5	11,0	173,5	10,5	BLACK	15/5								
			10 CL750-D38	26,0	48,0	20,0	25,5	11,0	154,5	10,5	BLACK	15/5								
1500	MCM	4500	12 CL750-DN	26,0	48,0	20,0	44,5	14,0	176,5	13,2	BLACK	15/5					B15MD			



CL series lugs are manufactured from electrolytic Copper tube with a purity greater than 99.9%.

The dimensions of the tube are designed to obtain the most efficient electrical conductivity and mechanical strength to resist vibration and pull out.

Cembre lugs are annealed to guarantee optimum ductility, an absolute necessity for connectors which will have to withstand the severe deformation arising when compressed and any bending of the palm during installation.

In applications subject to vibration, terminals have to perform a reliable connection, the annealing process plays a vital role in avoiding cracking or breaks between the barrel and palm.

The barrel length has been designed to allow easy and accurate positioning of the dies during the crimping operation.

Lugs are electrolytically Tin plated to avoid oxidation.

The tongue is clearly marked with wire size and die index for Cembre tools.

UL listed for US and Canada per UL486A up to 35 KV.

CL series lugs are an important part of Cembre crimping systems for power carrying conductors.

Details of the appropriate crimping tools and dies are shown on page 257.

Cembre technicians are available to provide technical advice as required. Please consult Cembre for products not listed.

long barrel - for Copper conductors

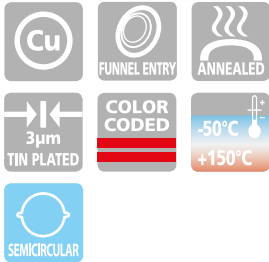
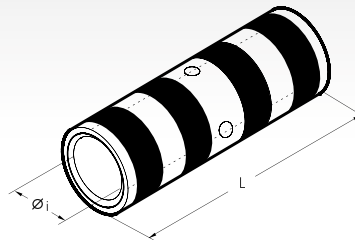

BSCL range of connectors are designed for joining low voltage conductors in heavy duty applications. Made of electrolytic Copper tube with a purity greater than 99.9%, having the same dimension as C and CL series lugs, BSCL connectors are annealed and electrolytically Tin plated. They feature an internal taper at both ends to ease the introduction of the conductor and a central stop to ensure correct positioning.

UL listed for US and Canada per UL486A up to 35 KV.

Appropriate crimping tools and dies are shown in details on page 257.

Conductor Size sqmm (AWG)	Conductor Size AWG	Type	Dimensions mm		Colour Code	Quantity Box/Bag	Mechanical Tools			Hydraulic Tools			
			Ø1	L			HN1	HN5	TN70	TN120S	B15MD	HT51 RH50 B500ND	HTT20 and tools and heads with 130 kN crimping force
10	8	BSCL8	4,6	50,5	RED	600/150	TN70	TN120S	B15MD	HT51 RH50 B500ND	HTT20 and tools and heads with 130 kN crimping force	ECW-HBD	RHU520
16	6	BSCL6	5,8	50,5	BLUE	400/100							
25	4	BSCL4	6,2	60,5	GREY	200/100							
	3	BSCL3	7,0	60,5	WHITE	200/50							
35	2	BSCL2	7,6	60,5	BROWN	200/50							
	1	BSCL1	8,9	65,5	GREEN	200/50							
50	1/0	BSCL1/0	10,0	73,0	PINK	200/50							
70	2/0	BSCL2/0	11,3	79,0	BLACK	100/50							
95	3/0	BSCL3/0	12,4	79,0	ORANGE	80/40							
	4/0	BSCL4/0	13,5	85,5	PURPLE	50/25							
120	250 MCM	BSCL250	15,2	85,5	YELLOW	50/25							
150	300 MCM	BSCL300	16,7	104,5	WHITE	40/20							
185	350 MCM	BSCL350	17,6	104,5	RED	40/20							
	400 MCM	BSCL400	19,2	111,0	BLUE	20/10							
240	500 MCM	BSCL500	21,1	117,0	BROWN	20/10							
300	600 MCM	BSCL600	23,7	139,5	GREEN	20/10							
	750 MCM	BSCL750	26,0	149,0	BLACK	10/10							

SLEEVE CONNECTORS

for Copper conductors

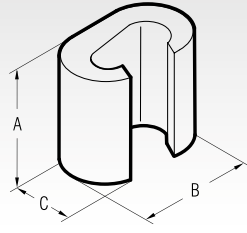

C-C

tin plated version

Conductor Size sqmm		Type	Dimensions mm			Quantity Box/Bag	Mechanical Tools	Hydraulic Tools			
Run	Tap		A	B	C			HT45-E	B450ND-BV	B500ND	B600
6÷2,5	6÷1,5	C6-C6ST*	9,0	9,8	6,4	1.000/100	HP4-C10	B450ND-BV	B500ND	B600	HT120 and tools and heads with 130 kN crimping force
10	10÷1,5	C10-C10ST*	12,0	12,6	8,4	500/100					
16	16÷1,5	C16-C16ST	17,0	19,4	12,0	500/100	HT45-E	B500	RH61	RHU81	ECW-H3D
25÷16	10÷1,5	C25-C10ST	17,0	19,8	13,0	400/50					
25	25÷16	C25-C25ST	17,0	21,4	13,0	300/50	HT51	RH50	RH61	RHU81	ECW-H3D
40÷35	16÷1,5	C35-C16ST	21,0	24,6	15,4	200/25					
40÷35	40÷25	C35-C35ST	21,0	26,6	15,6	200/25	HT51	RH50	RH61	RHU81	ECW-H3D
50	25÷10										
70÷63	25÷1,5	C70-C25N-ST	21,0	26,4	17,5	200/50	HT51	RH50	RH61	RHU81	ECW-H3D
50	25÷4	C50-C25ST	25,0	32,9	21,0	100/25					
50	50÷35	C50-C50ST	26,0	33,0	21,0	100/25	HT51	RH50	RH61	RHU81	ECW-H3D
70÷50	40÷4	C70-C35ST	28,0	33,0	21,0	100/25					
70÷50	70÷35	C70-C70ST	28,0	34,0	21,0	100/25	HT51	RH50	RH61	RHU81	ECW-H3D
100÷95	40÷4	C95-C35ST	29,0	40,6	26,0	50/25					
100÷95	70÷40	C95-C70ST	29,0	41,0	26,0	50/25	HT51	RH50	RH61	RHU81	ECW-H3D
100÷95	100÷63	C95-C95ST	29,0	41,0	26,0	50/25					
125÷110	125÷25	C120-C120ST	30,0	45,0	28,0	30/15	HT51	RH50	RH61	RHU81	ECW-H3D
160÷150	125÷25	C150-C120ST	31,0	45,0	28,0	50/25					
125	125										
150	150÷63	C150-C150ST	30,0	45,0	28,0	50/25	HT51	RH50	RH61	RHU81	ECW-H3D
125	125										
185	100÷16	C185-C95ST	31,0	45,0	28,0	30/15	HT51	RH50	RH61	RHU81	ECW-H3D
185÷120	185÷120	C185-C185ST	22,6	68,0	34,0	30/15					
240÷150	120÷95	C240-C120ST	22,6	68,0	34,0	30/15	HT51	RH50	RH61	RHU81	ECW-H3D

*Given the small size, on these connectors, only the type is engraved

bright surface version

Conductor Size sqmm		Type	Dimensions mm			Quantity Box/Bag	Mechanical Tools	Hydraulic Tools			
Run	Tap		A	B	C			HT45-E	B450ND-BV	B500ND	B600
6÷2,5	6÷1,5	C6-C6*	9,0	9,8	6,4	1.000/100	HP4-C10	B450ND-BV	B500ND	B600	HT120 and tools and heads with 130 kN crimping force
10	10÷1,5	C10-C10*	12,0	12,6	8,4	500/100					
16	16÷1,5	C16-C16	17,0	19,4	12,0	500/100	HT45-E	B500	RH61	RHU81	ECW-H3D
25÷16	10÷1,5	C25-C10	17,0	19,8	13,0	400/50					
25	25÷16	C25-C25	17,0	21,4	13,0	300/50	HT51	RH50	RH61	RHU81	ECW-H3D
40÷35	16÷1,5	C35-C16	21,0	24,6	15,4	200/25					
40÷35	40÷25	C35-C35	21,0	26,6	15,6	200/25	HT51	RH50	RH61	RHU81	ECW-H3D
50	25÷10										
70÷63	25÷1,5	C70-C25N	21,0	26,4	17,5	200/25	HT51	RH50	RH61	RHU81	ECW-H3D
50	25÷4	C50-C25	25,0	32,9	21,0	100/25					
50	50÷35	C50-C50	26,0	33,0	21,0	100/25	HT51	RH50	RH61	RHU81	ECW-H3D
70÷50	40÷4	C70-C35	28,0	33,0	21,0	100/25					
70÷50	70÷35	C70-C70	28,0	34,0	21,0	100/25	HT51	RH50	RH61	RHU81	ECW-H3D
100÷95	40÷4	C95-C35	29,0	40,6	26,0	50/25					
100÷95	70÷40	C95-C70	29,0	41,0	26,0	50/25	HT51	RH50	RH61	RHU81	ECW-H3D
100÷95	100÷63	C95-C95	29,0	41,0	26,0	50/25					
125÷110	125÷25	C120-C120	30,0	45,0	28,0	30/15	HT51	RH50	RH61	RHU81	ECW-H3D
160÷150	125÷25	C150-C120	31,0	45,0	28,0	30/15					
125	125										
150	150÷63	C150-C150	30,0	45,0	28,0	30/15	HT51	RH50	RH61	RHU81	ECW-H3D
125	125										
185	100÷16	C185-C95	31,0	45,0	28,0	50/25	HT51	RH50	RH61	RHU81	ECW-H3D
185÷120	185÷120	C185-C185	22,6	68,0	34,0	30/15					
240÷150	120÷95	C240-C120	22,6	68,0	34,0	30/15	HT51	RH50	RH61	RHU81	ECW-H3D

*Given the small size, on these connectors, only the type is engraved

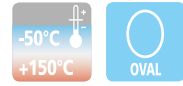

"C" connectors are manufactured from Copper profiles with a purity greater than 99.9%, and are suitable for a variety of uses either to create an earthing network or tapping off from overhead distribution lines.

Each connector is marked as follows:

- Cembre trade mark
- Reference number
- Conductor size-Run
- Conductor size-Tap
- Number of crimps
- Die reference.

Details of the appropriate crimping tools and dies are shown on page 252.



Example of tap connection

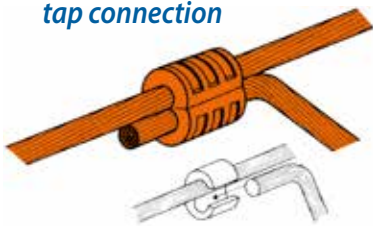

Example of joint connection

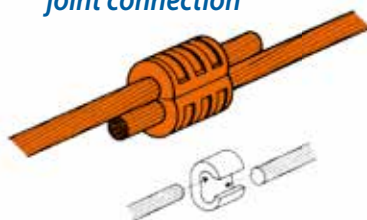

Example of joining two running conductors

Conductor Size sqmm	Type
25-25	C35-C16
35-35	C35-C35
50-50	C70-C70
63-63	C95-C70
70-70	
95-95	C150-C120
120-120	C150-C150
120-120	C185-C95
125-125	

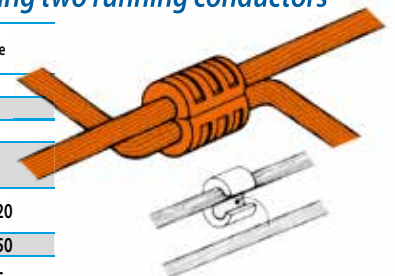

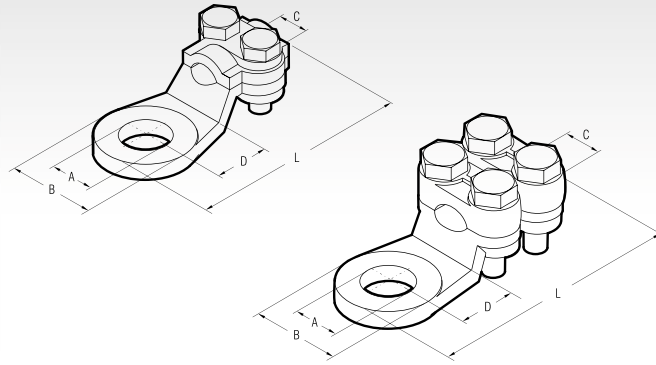

BRASS

Steel
ZINC PLATED-50°C
+150°C

Material:
Brass CB754S EN 1982 Nickel plated.
Zinc plated Steel bolts.

2 bolt fixing lugs

Conductor Size sqmm	Type	Clamping Bolt		Ø A Bolt	Dimensions mm				Quantity
		Ø	Torque Ratio Nm		B	C	D	L	
16	2155	M5	3	M8	18,0	4,5	12,5	39	100
16	2171	M5	3	M10	18,0	4,5	12,5	39	100
25	2156	M5	3	M8	19,5	6,0	13,0	43	100
25	2172	M5	3	M10	19,5	6,0	13,0	43	100
35	2157	M5	3	M12	23,0	7,0	15,0	49	50
35	2173	M5	3	M14	23,0	7,0	15,0	49	50
50	2174	M6	5	M14	25,0	8,0	17,0	56	50

4 bolt fixing lugs

Conductor Size sqmm	Type	Clamping Bolt		Ø A Bolt	Dimensions mm				Quantity
		Ø	Torque Ratio Nm		B	C	D	L	
50	2158	M6	5	M12	23,5	8	16,0	57	50
75	2160	M6	5	M12	28,0	10	20,0	65	25
75	2176	M6	5	M16	28,0	10	20,0	65	25
100	2161	M6	5	M12	31,0	13	17,0	66	25
125	2162	M7	10	M15	33,0	14	18,0	71	25
150	2163	M7	10	M14	34,0	16	19,5	75	25
175	2164	M7	10	M15	36,0	16	21,0	78	25

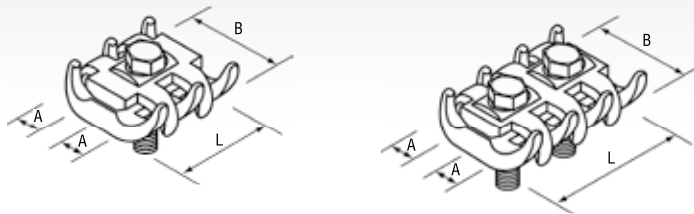

Single bolt fixing

Conductor Size sqmm	Type	Clamping Bolt		A for Cable mm	Dimensions mm		Quantity
		∅	Torque Ratio Nm		B	L	
6÷16	2323	M6	8	3÷ 5	24	20	50
16÷50	2326	M8	15	5÷ 8	30	25	50
35÷70	2329	M8	15	7÷12	40	30	25

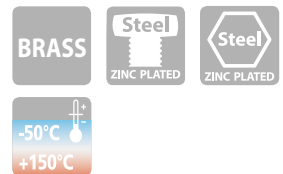

2 bolt fixing

Conductor Size sqmm	Type	Clamping Bolt		A for Cable mm	Dimensions mm		Quantity
		∅	Torque Ratio Nm		B	L	
6÷16	2333	M6	8	3÷ 5	24,5	30	50
16÷50	2336	M8	15	5÷ 8	32,0	40	50
35÷70	2339	M8	15	7÷12	40,0	44	25
50÷95	2342	M10	35	8÷14	48,0	48	10
70÷150	2344	M10	35	12÷16	51,0	53	10
150÷300	2346*	M12	60	16÷22	66,0	66	5

*Stainless Steel bolts

Material:
Brass CB754S EN 1982 Zinc plated
Steel bolts.
Zinc plated Steel nut.

CA-M 2A-M

HIGH VOLTAGE COPPER TERMINALS

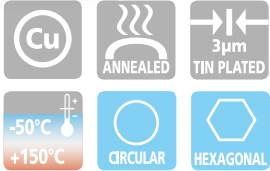
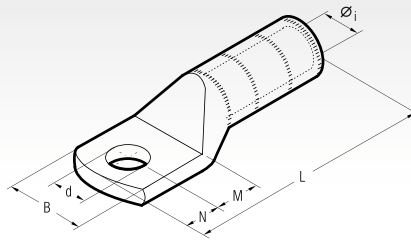

Series CA-M and 2A-M terminals are designed for high voltage applications up to 33 kV.

They are manufactured from Copper tube with a purity greater than 99.9%, annealed and Tin plated.

The extended barrel enhances both electrical and mechanical performance. The absence of an inspection hole prevents moisture entry into the crimped joint and makes these terminals suitable for outdoor applications.

Details of the appropriate crimping tools and dies are shown on page 252.

Conductor Size sqmm	Ø Stud mm	Type	Dimensions mm						Quantity Box/Bag	Hydraulic Tools	
			Øi	B	M	N	L	d			
25 R	8	CA25-M8	6,8	14,0	9,0	8,0	65,0	8,4	300/50	HT51 RH50 RH61 RH81-U RHU81 ECW-H3D RHU520	HT120 and tools and heads with 130 kN crimping force
	10	CA25-M10	6,8	18,0	13,0	11,0	72,0	10,5	200/50		
	12	CA25-M12	6,8	21,0	16,0	14,0	78,0	13,2	150/50		
30 RC/S ÷ 40 S	12	CA40S-M12	8,2	21,0	16,0	14,0	79,0	13,2	100/50		
	16	CA40S-M16	8,2	26,0	19,0	17,0	85,0	17,0	100/50		
50 RC	12	CA50R-M12	8,7	20,5	16,0	14,0	79,0	13,2	100/50		
50 S	12	CA50S-M12	9,5	21,0	16,0	14,0	79,0	13,2	100/50		
	16	CA50S-M16	9,5	26,0	19,0	17,0	85,0	17,0	100/50		
63 S ÷ 70 S	12	CA70S-M12	11,0	28,0	16,0	14,0	81,2	13,2	50/25		
	16	CA70S-M16	11,0	30,0	19,0	17,0	87,2	17,0	50/25		
80 S ÷ 95 RC	12	CA95R-M12	12,0	28,0	16,0	14,0	91,0	13,2	30/15		
	14	CA95R-M14	12,0	28,0	18,0	16,0	95,0	15,0	50/25		
95 S ÷ 100 S	12	CA95S-M12	13,5	28,0	16,0	14,0	91,0	13,2	30/15		
	14	CA95S-M14	13,5	29,0	18,0	16,0	94,5	15,0	50/25		
	16	CA95S-M16	13,5	30,0	20,0	17,0	97,0	17,0	50/25		
120 RC/S ÷ 150 RC	12	CA150R-M12	15,0	31,0	16,0	14,0	97,0	13,2	30/15		
	14	CA150R-M14	15,0	31,0	18,0	16,0	101,0	15,0	30/15		
150 S ÷ 160 RC	12	CA150S-M12	16,5	32,0	16,0	14,0	97,0	13,2	30/15		
	14	CA150S-M14	16,5	32,0	18,0	16,0	101,0	15,0	30/15		
160 S ÷ 200 RC	14	CA200R-M14	17,0	32,5	18,0	16,0	101,0	15,0	30/15		
200 S ÷ 240 RC	14	CA240R-M14	19,2	43,0	18,0	16,0	107,0	15,0	15/5		
240 S ÷ 315 RC	14	CA315R-M14	21,5	43,0	18,0	16,0	105,0	15,0	15/5		
315 S	14	CA315S-M14	23,7	44,0	18,0	16,0	105,0	15,0	15/5		
	14	2A80-M14*	27,0	51,0	22,0	19,0	140,0	15,0	15/5		
400 R	16	2A80-M16*	27,0	51,0	22,0	19,0	140,0	17,0	15/5		
	20	2A80-M20*	27,0	51,0	24,0	23,0	146,0	21,0	15/5		
	16	2A100-M16	30,3	56,5	22,0	19,0	147,0	17,0	10/1		
500 R	20	2A100-M20	30,3	56,5	24,0	23,0	153,0	21,0	10/1		
	16	2A120-M16	33,4	61,5	22,0	19,0	159,0	17,0	20/1		
600 R ÷ 630 R	16	2A120-M20	33,4	61,5	24,0	23,0	165,0	21,0	20/1		
	20	2A120-M20	33,4	61,5	24,0	23,0	165,0	21,0	20/1		

*UL marking

R = Round conductors RC = Round Compact conductors S = Sector shaped conductors

HIGH VOLTAGE TERMINALS

two hole fixing

CA-2M 2A-2M

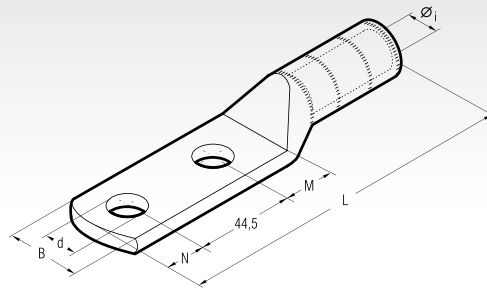

Conductor Size sqmm	Ø Stud mm	Type	Dimensions mm					Quantity Box/Bag	Hydraulic Tools	
			Øi	B	M	N	L		d	
25 R	8	CA25-2M8	6,8	14,0	10,0	11,0	113,5	8,4	200/50	HT120 and tools and heads with 130 kN crimping force ECW-H3D RHU520
	12	CA25-2M12	6,8	21,0	16,0	14,0	122,5	13,2	100/50	
30 RC/S ÷ 40 S	12	CA40S-2M12	8,2	21,5	16,0	14,0	123,5	13,2	100/50	
50 RC	12	CA50R-2M12	8,7	20,5	16,0	14,0	123,5	13,2	100/50	
50 S	12	CA50S-2M12	9,5	21,0	16,0	14,0	123,5	13,2	100/50	
63 S ÷ 70 S	12	CA70S-2M12	11,0	27,0	16,0	14,0	127,7	13,2	50/25	
80 S ÷ 95 RC	14	CA95R-2M14	12,0	28,0	18,0	16,0	139,5	15,0	30/15	
95 S ÷ 100 S	14	CA95S-2M14	13,5	29,0	18,0	16,0	139,5	15,0	30/15	
120 RC/S ÷ 150 RC	14	CA150R-2M14	15,0	31,0	18,0	16,0	145,5	15,0	30/15	
150 S ÷ 160 RC	14	CA150S-2M14	16,5	32,0	18,0	16,0	145,5	15,0	30/15	
160 S ÷ 200 RC	14	CA200R-2M14	17,0	32,5	18,0	16,0	145,0	15,0	30/15	
200 S ÷ 240 RC	14	CA240R-2M14	19,2	43,0	18,0	16,0	151,5	15,0	15/5	
240 S ÷ 315 RC	14	CA315R-2M14	21,5	43,0	18,0	16,0	149,5	15,0	20/5	
315 S	14	CA315S-2M14	23,7	44,0	18,0	16,0	149,5	15,0	20/5	
400 R	12	2A80-2M12*	27,0	51,0	20,0	14,0	177,5	13,2	15/5	
	14	2A80-2M14*	27,0	51,0	22,0	16,0	181,5	15,0	15/5	
	16	2A80-2M16*	27,0	51,0	22,0	19,0	184,5	17,0	15/5	
500 R	14	2A100-2M14	30,3	56,5	22,0	16,0	182,5	15,0	10/5	
	16	2A100-2M16	30,3	56,5	22,0	19,0	185,5	17,0	10/5	
600 R ÷ 630 R	14	2A120-2M14	33,4	61,5	22,0	16,0	200,5	15,0	15/5	
	16	2A120-2M16	33,4	61,5	22,0	19,0	202,5	17,0	15/5	

*UL marking

R = Round conductors RC = Round Compact conductors S = Sector shaped conductors

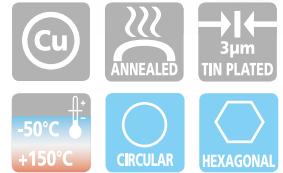

CA-2M and 2A-2M Copper Tube Terminal Lugs are designed for high voltage applications up to 33kV. Manufactured from Copper tube with a purity greater than 99.9%, annealed and Tin plated. The extended barrel enhances electrical and mechanical performance.

The absence of an inspection hole prevents moisture entry into the crimped joint. Featuring an extended palm with two fixing holes at 44.5 mm centres.

Details of the appropriate crimping tools and dies are shown on page 252.

HIGH VOLTAGE TERMINALS

palm bent at 55° - two hole fixing

2A-2M/55°

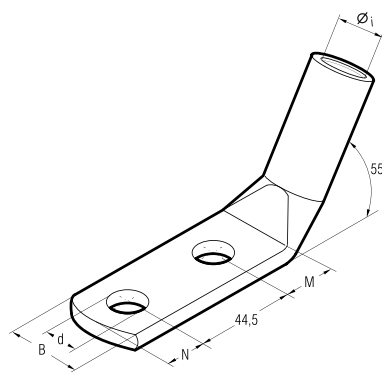

Conductor Size sqmm	Ø Stud mm	Type	Dimensions mm					Quantity Box/Bag	Hydraulic Tools	
			Øi	B	M	N	d			
400 R	14	2A80-2M14/55°	27,0	51,0	22	16	15	10/5	HT120 and tools and heads with 130 kN crimping force ECW-H3D RHU520	
600 R ÷ 630 R	14	2A120-2M14/55°	33,4	61,5	22	16	15	15/3		

R = Round conductors



The 2A-2M/55° Copper Tube Terminal Lugs have the same characteristics as the CA-2M and 2A-2M ranges, with the additional feature of the palm bent at 55°.

Details of the appropriate crimping tools and dies are shown on page 252.

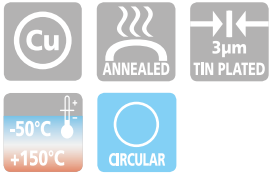
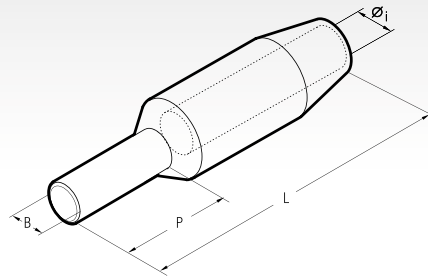

MT-C series connectors are designed for high voltage applications up to 33 kV.

They are manufactured from Copper with a purity greater than 99.9%, annealed and Tin plated.

The extended barrel enhances both electrical and mechanical performance.

The stalk or pin makes these connectors ideal for terminating conductors into contact blocks.

Details of the appropriate crimping tools and dies are shown on page 252.

Conductor Size sqmm	Type	Dimensions mm				Quantity Box/Bag	Hydraulic Tools				
		Øi	B	P	L		HT51	RH50	B500	B500ND	
25 R	MT25-C8	6,8	8,0	35,0	80,0	90/3					
	MT40S-C8	8,2	8,0	35,0	80,0	90/3					
30 RC/S ÷ 40 S	MT40S-C10	8,2	10,0	35,0	80,0	90/3					
	MT40S-C14-80	8,2	14,0	80,0	123,0	30/3					
50 RC	MT50R-C8	8,8	8,0	35,0	80,0	90/3					
	MT50R-C10	8,8	10,0	35,0	80,0	90/3					
50 S	MT50S-C8	9,5	8,0	35,0	80,0	90/3					
	MT50S-C10	9,5	10,0	35,0	80,0	90/3					
	MT50S-C14-80	9,5	14,0	80,0	123,0	30/3					
63 S ÷ 70 S	MT70S-C10	11,2	10,0	35,0	90,0	30/3					
80 S ÷ 95 RC	MT95R-C10	12,0	10,0	45,0	110,0	60/3					
	MT95R-C12	12,0	12,0	45,0	110,0	60/3					
95 S ÷ 100 S	MT95S-C10	13,5	10,0	45,0	110,0	60/3					
	MT95S-C12	13,5	12,0	45,0	110,0	60/3					
	MT95S-C14-80	13,5	14,0	80,0	145,0	60/3					
120 RC/S ÷ 150 RC	MT150R-C12	15,0	12,0	45,0	110,0	60/3					
	MT150R-C16	15,0	16,0	45,0	110,0	30/3					
150 S ÷ 160 RC	MT150S-C12	16,5	12,0	45,0	110,0	60/3					
	MT150S-C14-80	16,5	14,0	80,0	145,0	45/3					
160 S ÷ 200 RC	MT150S-C16	16,5	16,0	45,0	110,0	60/3					
	MT200R-C10	17,0	10,0	45,0	110,0	30/3					
200 S ÷ 240 RC	MT200R-C16	17,0	16,0	45,0	110,0	30/3					
	MT240R-C12	19,5	12,0	50,0	115,0	30/3					
240 S ÷ 315 RC	MT240R-C16	19,5	16,0	50,0	115,0	30/3					
	MT315R-C16	21,5	16,0	50,0	115,0	30/3					
315 S	MT315S-C16	24,0	16,0	60,0	130,0	30/3					

R = Round conductors RC = Round Compact conductors S = Sector shaped conductors

HIGH VOLTAGE COPPER THROUGH CONNECTORS

MT-TD MT-GC

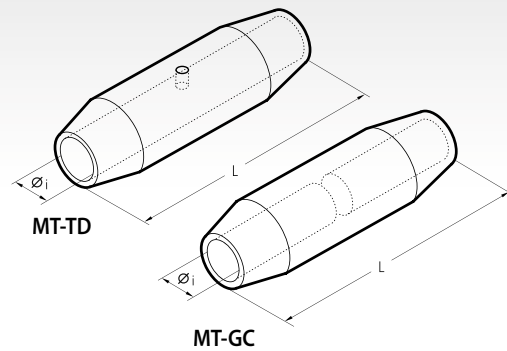

Conductor Size sqmm	Type	Type	Dimensions mm		Quantity Box/Bag	Hydraulic Tools				
			\varnothing_i	L						
25 R	MT25-TD	MT25-GC	6,8	60,0	90/3	HT51 RH50 B500 B500ND	HT61 RH61 B600	HT81-U RHU81	HT120 and tools and heads with 130 kN crimping force	ECW-H3D RHU520
30 RC/S ÷ 40 S	MT40S-TD	MT40S-GC	8,2	60,0	90/3					
50 RC	MT50R-TD	MT50R-GC	8,7	60,0	90/3					
50 S	MT50S-TD	MT50S-GC	9,5	60,0	90/3					
63 S ÷ 70 S	MT70S-TD	MT70S-GC	11,0	70,0	30/3					
80 S ÷ 95 RC	MT95R-TD	MT95R-GC	12,0	80,0	30/3					
95 S ÷ 100 S	MT95S-TD	MT95S-GC	13,5	80,0	30/3					
120 RC/S ÷ 150 RC	MT150R-TD	MT150R-GC	15,0	80,0	30/3					
150 S ÷ 160 RC	MT150S-TD	MT150S-GC	16,5	80,0	30/3					
160 S ÷ 200 RC	MT200R-TD	MT200R-GC	17,0	100,0	30/3					
200 S ÷ 240 RC	MT240R-TD	MT240R-GC	19,2	100,0	30/3					
240 S ÷ 315 RC	MT315R-TD	MT315R-GC	21,5	100,0	30/3					
315 S	MT315S-TD	MT315S-GC	23,7	100,0	30/3					
400 R	MT400-TD		27,0	120,0	15/3					
500 R	MT500-TD		30,3	118,0	15/3					
600 R ÷ 630 R	MT630-TD		33,4	130,0	9/3					

R = Round conductors RC = Round Compact conductors S = Sector shaped conductors



MT-TD and MT-GC series connectors are designed to join conductors in high voltage applications up to 33 kV.

They are manufactured from Copper with a purity greater than 99.9%, annealed and Tin plated.

MT-GC series feature a solid stop which forms a barrier between the two conductors being joined, this prevents the migration of oils or greases, which may be present, in one cable contaminating the other cable.

MT-TD connectors are unblocked and are suitable for joining cables of the same type.

Details of the appropriate crimping tools and dies are shown on page 252.

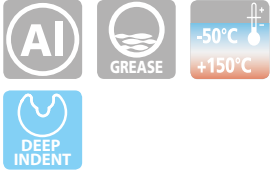
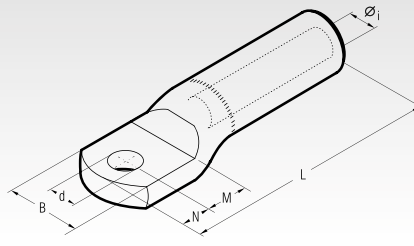

AA-M series terminals are made from Aluminium of a purity equal to or greater than 99,5%. They are designed to accept a variety of conductor forms especially low stranded compacted conductors. Non circular conductors may require pre-rounding prior to introduction to the terminal. Barrels are capped and filled with grease so as to avoid oxidation of the Aluminium. Details of the appropriate crimping tools and dies are shown on page 253.

Conductor Size sqmm	Ø Stud mm	Type	Dimensions mm						Quantity Box/Bag	Hydraulic Tools		
			Øi	B	M	N	L	d				
16	8	AA16-M8	5,5	21	13	11	77,0	8,4	60/3	HT131-UC	RHU131-C	B1300-UC
25	8	AA25-M8	6,5	21	13	11	77,0	8,4	60/3			
35	8	AA35-M8	8,0	23	13	11	77,5	8,4	60/3			
	10	AA35-M10	8,0	23	13	11	77,5	10,5	60/3			
50	12	AA50-M12	9,0	26	16	14	91,0	13,2	60/3			
	14	AA50-M14	9,0	26	18	16	95,0	15,0	60/3			
70	12	AA70-M12	11,0	27	16	14	91,0	13,2	45/3			
	14	AA70-M14	11,0	27	18	16	95,0	15,0	45/3			
95	12	AA95-M12	12,5	27	16	14	91,0	13,2	45/3			
	14	AA95-M14	12,5	27	18	16	95,0	15,0	45/3			
120	12	AA120-M12	13,7	35	16	14	115,0	13,2	30/3			
	14	AA120-M14	13,7	35	18	16	119,0	15,0	30/3			
150	12	AA150-M12	15,5	34	16	14	115,0	13,2	30/3			
	14	AA150-M14	15,5	34	18	16	119,0	15,0	30/3			
185	12	AA185-M12	17,0	42	20	14	122,0	13,2	18/3			
	14	AA185-M14	17,0	42	22	16	126,0	15,0	18/3			
240	12	AA240-M12	19,5	44	20	14	122,0	13,2	15/3			
	14	AA240-M14	19,5	44	22	16	126,0	15,0	15/3			
300	12	AA300-34M12	22,5	47	22	14	130,0	13,2	15/3	HT120	HT131-C	RHC131
	14	AA300-34M14	22,5	47	22	16	132,0	15,0	15/3			
	16	AA300-34M16	22,5	47	22	17	133,0	17,0	15/3			
400	16	AA300-M16	23,3	54	22	19	177,0	17,0	12/3	ECW-H3D	RHU 230-630	
400	16	AA400-M16	26,0	56	19	17	172,0	17,0	15/3			
500	16	AA500-40M16	29,1	57	22	19	177,0	17,0	12/3			
630	16	AA630-M16	32,5	70	22	19	177,0	17,0	9/3			



THROUGH CONNECTORS

for Aluminium conductors

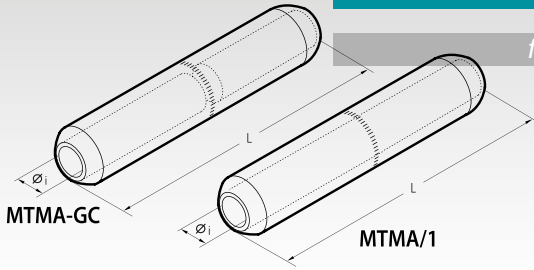

MTMA-GC MTMA/1



Conductor Size sqmm	Type	Type	Dimensions mm		Quantity Box/Bag	Hydraulic Tools	
			øi	L			
10	MTMA10-GC		4,3	90,5	60/3	B1300-UC	
16	MTMA16-GC	MTMA16/1	5,5	90,5	60/3		
25	MTMA25-GC	MTMA25/1	6,5	90,5	60/3		
35	MTMA35-GC	MTMA35/1	8,0	90,5	60/3		
	MTMA35-20-GC		8,0	106,5	30/3		
50	MTMA50-GC	MTMA50/1	9,0	106,5	30/3		
70	MTMA70-GC	MTMA70/1	11,0	106,5	30/3		
95	MTMA95-GC		12,5	110,0	30/3		
		MTMA95/1	12,5	106,5	30/3		
120	MTMA120-GC	MTMA120/1	13,7	133,0	30/3		
150	MTMA150-GC		15,5	135,0	30/3		
185		MTMA150/1	15,5	133,5	30/3		
	MTMA185-GC	MTMA185/1	17,0	143,5	15/3		
240	MTMA240-GC	MTMA240/1	19,5	143,5	15/3	HT120 HT131-C RHC131	
300	MTMAD300-GC		22,5	144,5	15/3		
		MTMAD300/1	22,5	135,0	15/3		
	MTMA300-GC		23,3	218,0	15/3	ECW-H3D	RHU230-630
400		MTMA400/1	26,0	218,0	15/3		
500	MTMA500-GC		29,1	218,5	12/3		
630		MTMA500-40/1	29,1	218,0	15/3		
		MTMA630/1	32,5	218,5	12/3		

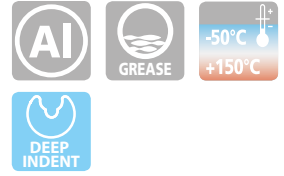

MTMA-GC series through connectors are made from Aluminium of a purity equal to or greater than 99,5%. They feature a solid stop which creates a barrier between the two sides of conductors to be joined. Barrels are capped and filled with grease so as to avoid oxidation of the connector. MTMA/1 series through connectors are unblocked and are suitable for joining cables of the same type. Details of the appropriate crimping tools and dies are shown on pages 254-255.

REDUCER THROUGH CONNECTORS

for Aluminium or Copper conductors

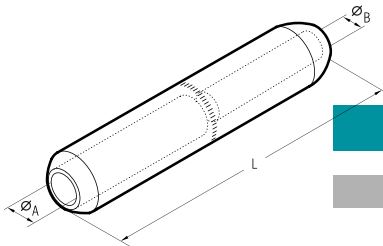

MTMA-GC



Conductor Size sqmm		Type	Dimensions mm			Quantity Box/Bag	Hydraulic Tools	
Side A Al	Side B Al/Cu		øA	øB	L			
16	10	MTMA 16-10-GC	5,5	4,3	90,5	60/3	B1300-UC	
25	10	MTMA 25-10-GC	6,5	4,3	90,5	60/3		
	16	MTMA 25-16-GC	6,5	5,5	90,5	60/3		
50	25	MTMA 50-25-GC	9,0	6,5	106,5	30/3		
	35	MTMA 50-35-GC	9,0	8,0	106,5	30/3		
70	35	MTMA 70-35-GC	11,0	8,0	106,5	30/3		
	50	MTMA 70-50-GC	11,0	9,0	106,5	30/3		
95	50	MTMA 95-50-GC	12,5	9,0	109,4	30/3		
	70	MTMA 95-70-GC	12,5	11,0	106,5	30/3		
120	70	MTMA 120-70-GC	13,7	11,0	133,0	30/3		
	95	MTMA 120-95-GC	13,7	12,5	133,0	30/3		
150	70	MTMA 150-70-GC	15,5	11,0	133,0	30/3		
	95	MTMA 150-95-GC	15,5	12,5	134,4	30/3		
185	120	MTMA 150-120-GC	15,5	13,7	133,0	30/3		
	120	MTMA 185-120-GC	17,0	13,7	143,5	15/3		
240	150	MTMA 185-150-GC	17,0	15,5	143,5	15/3		
	150	MTMA 240-150-GC	19,5	15,5	143,5	15/3		
300	185	MTMA 240-185-GC	19,5	17,0	143,5	15/3		
	95	MTMAD 300-95-GC	22,5	12,5	144,5	15/3		
400	150	MTMAD 300-150-GC	22,5	15,5	144,5	15/3		
	185	MTMAD 300-185-GC	22,5	17,0	144,5	15/3		
500	240	MTMAD 300-240-GC	22,5	19,5	144,5	15/3		
	240	MTMA 400-240-GC	26,0	19,5	218,0	15/3		
500	300	MTMA 400-300-GC	26,0	23,3	218,0	15/3		
	300	MTMA 500-300-GC	29,1	23,3	218,5	12/3		
	400	MTMA 500-400-GC	29,1	26,0	218,5	12/3		

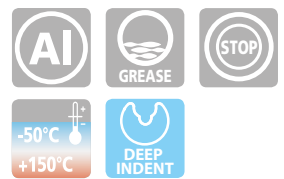

MTMA-GC series reducer through connectors are manufactured to the same specification as MTMA-GC series through connectors. Details of the appropriate crimping tools and dies are shown on pages 254-255.

CAA-M

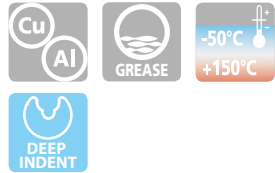

The barrels of series CAA-M connectors are made from Aluminium of a purity equal to or greater than 99,5%. The barrel is friction welded to the palm thus achieving the best possible transition between the Copper palm and Aluminium barrel. Barrels are capped and filled with grease so as to avoid oxidation of the Aluminium. Details of the appropriate crimping tools and dies are shown on pages 253, 255.

BIMETALLIC CONNECTORS

Copper palm fixing - Aluminium barrels

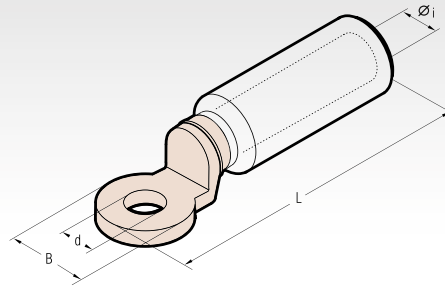

Conductor Size sqmm	Ø Stud mm	Type	Dimensions mm				Quantity Box/Bag	Hydraulic Tools	
			Øi	B	L	d			
10	12	CAA10-M12	4,3	24,0	87,0	13,0	90/3	HT131-UC RHU131-C BT300-UC	
16	12	CAA16-M12	5,5	24,0	87,0	13,0	90/3		
25	12	CAA25-M12	6,5	24,0	87,0	13,0	90/3		
35	12	CAA35-M12	8,0	24,0	87,0	13,0	90/3		
	12	CAA35-20-M12	8,0	24,0	87,0	13,0	60/3		
50	12	CAA50-M12	9,0	24,0	87,0	13,0	60/3		
70	12	CAA70-M12	11,0	24,0	87,0	13,0	60/3		
95	12	CAA95-M12	12,5	24,0	87,0	13,0	60/3		
120	12	CAA120-M12	13,7	31,0	111,0	13,0	30/3		
150	12	CAA150-M12	15,5	31,0	111,0	13,0	30/3		
185	12	CAA185-M12	17,0	35,0	116,0	13,0	18/3		
240	12	CAA240-M12	19,5	35,0	116,0	13,0	18/3		
	12	CAA300-34-M12	22,5	35,0	120,0	13,0	15/3		
300	16	CAA300-34-M16	22,5	35,0	120,0	17,0	15/3		
	16	CAA300-M16	23,3	35,0	152,5	16,5	12/3		
400	16	CAA400-M16	26,0	35,0	152,5	16,5	12/3		
500	16	CAA500-M16TNBD	29,1	35,0	152,5	16,5	12/3		
630	8	CAA630-4M8	32,5	60,0	200,0	4 x 9,0*	9/3		

* 4 holes with 30 mm between axes

MTA-C

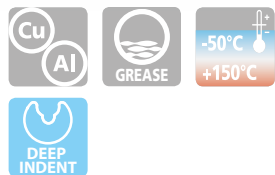

The barrels of series MTA-C connectors are made from Aluminium of a purity equal to or greater than 99,5%. The barrel is friction welded to the pin thus achieving the best possible transition between the Copper pin and Aluminium barrel. Barrels are capped and filled with grease so as to avoid oxidation of the Aluminium. Details of the appropriate crimping tools and dies are shown on pages 253, 255.

BIMETALLIC CONNECTORS

Copper pin - Aluminium barrels

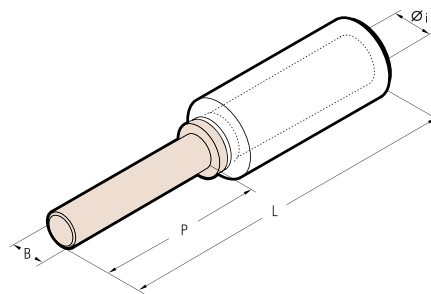

Conductor Size sqmm	Type	Dimensions mm				Quantity Box/Bag	Hydraulic Tools
		Øi	B	P	L		
16	MTA16-C	5,5	8	30	82	90/3	HT131-UC RHU131-C BT300-UC
25	MTA25-C	6,5	8	30	82	90/3	
35	MTA35-C	8,0	8	30	82	90/3	
50	MTA50-C	9,0	12	45	97	60/3	
70	MTA70-C	11,0	12	45	97	60/3	
95	MTA95-C	12,5	12	45	97	60/3	
120	MTA120-C	13,7	14	55	125	30/3	
150	MTA150-C	15,5	14	55	125	30/3	
185	MTA185-C	17,0	14	55	125	24/3	
240	MTA240-C	19,5	14	55	125	24/3	

MECHANICAL LUGS

MLA-C

For Low and Medium voltage Al/Cu conductors

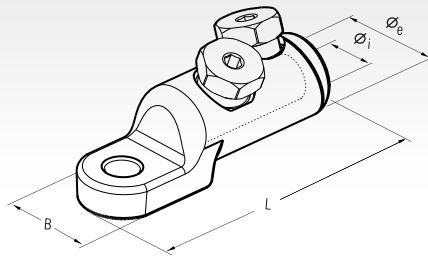

Conductor Size sqmm	Type	Ø Stud mm	Dimensions mm				N° of Bolts	Number of centring devices	Quantity Box/Bag
			Øe	Øi	B	L			
50-240	MLA50-240-12C	12	33	20,5	33	106,5*	2	3 ● ● ●	1/10

*without centring devices



Cembre range-taking mechanical connectors are intended for use with Copper and Aluminium conductors, for low and medium voltage (up to 52kV) installations, in indoor, outdoor and underground applications. Mechanical connector bodies (pic.1) are made from Aluminium EN-AW 2011 T6 with cross sectional area and barrel length designed to optimise

electrical connectivity. Internal surfaces are protected against oxidation by grease with a very high dropping point, while the Tin plating on external surfaces has a minimum thickness of 12 µm for improved surface protection. Shear bolts (pic.2) are made from the same material and designed to ensure a reliable electrical connection

simply by tightening the bolts with a standard socket until shearing occurs inside the threaded hole without external protrusion. To minimise voltage stresses, connectors are provided with centring devices (pic.3) to improve the alignment of the different conductor sizes.

Key features:

- Wide range of conductor cross sections
- Suitable for Copper and Aluminium conductors
- Tested according to IEC 61238
- Torque controlled to guarantee a good electrical contact
- Reduces inventory levels
- Easy installation - only requires a standard socket
- Reduced installation time

Pic. 1



Conductor Size sqmm	Centring device	
	Color	Type
50 - 70 - 95	Red	
120 - 150	Blue	
185	Yellow	
240	Not required	

Pic. 3

ML-C



MECHANICAL LUGS WITH SYMMETRICAL PALM

For Medium voltage Al/Cu conductors

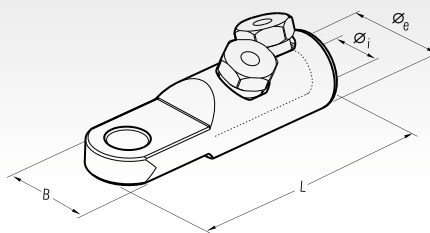

Conductor Size sqmm	Type	Ø Stud mm	Dimensions mm				N° of Bolts	Number of centring devices	Quantity Box/Bag
			Øe	Øi	B	L			
95-240	ML95-240-12C	12	35	20,5	35	124*	2	3 ● ● ●	1/10
95-240	ML95-240-16C	16	35	20,5	35	124*	2	3 ● ● ●	1/10
150-240	ML150-240-12C	12	35	20,5	35	124*	2	2 ● ●	1/10
150-240	ML150-240-16C	16	35	20,5	35	124*	2	2 ● ●	1/10

* without centring devices

MBS-C

MECHANICAL SPLICES

For Low and Medium voltage Al/Cu conductors

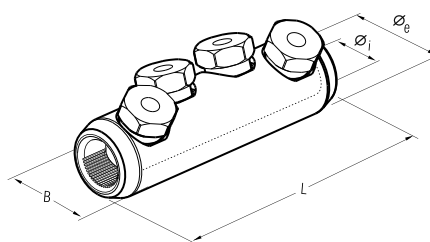

Conductor Size sqmm	Type	Dimensions mm				N° of Bolts	Number of centring devices	Quantity Box/Bag
		Øe	Øi	B	L			
50-240	MBS50-240-C	35	20,5	35	124*	4	3 ● ● ●	1/20
95-240	MBS95-240-C	35	20,5	35	124*	4	3 ● ● ●	1/20

* without centring devices



TERMINAL BLOCKS, FLEXIBLE BUSBAR AND BRAIDS

symbol description

terminal blocks



Polycarbonate body



Zinc plated Steel screws



Polyamide PA6.6 body



Chrome plated Steel screws



Polypropylene body



Brass clamp



Steatite body



Operating temperature range



Polyvinylchloride insulating sheath



Italian Institute of the Quality Mark type approval



Electrolytically Tin plated Copper interconnections



Lloyd's Register of Shipping type approval



Electrolytically Tin plated to avoid oxidation



Italian Naval Register type approval



Nominal voltage V



Marking CE



Degree of Protection IP20



Self-extinguishing class V0 UL94



example applications

terminal blocks

type
ZETApiù®

Z35T-11 uninterrupted,
main earth loop, terminal block.
Used for equipotential bonding

UNINTERRUPTED
MAIN EARTH
LOOP

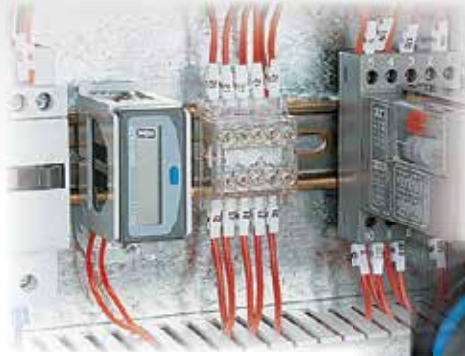
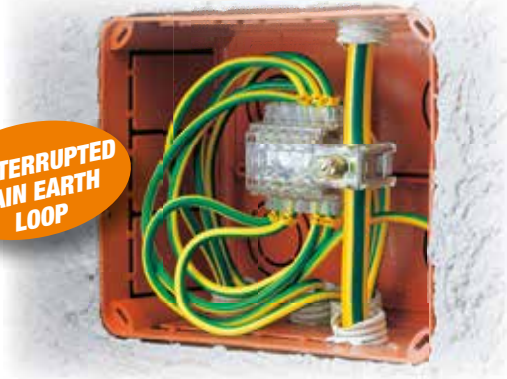

Z6-10D terminal blocks
used in a control panel.

SUITABLE
FOR DIN RAIL
MOUNTING



Z16-8D and Z6-6D
mounted on DIN rails.
Used in control panels

type
ZETAmini®

ZETAmini terminal blocks
used for domestic/commercial
applications.



type
ZETAblock®

A typical application of the
Z50-DP12-160 and Z35-DP14B-125
installed in a distribution panel



Z6

SINGLE POLE TERMINAL BLOCKS

indirect clamping - nominal section 6 sqmm

type
ZETApiù®



The "Z...D" version has been designed for mounting on DIN rails



Connecting Capacity sqmm	Type	No. of Ways	Nominal Voltage V	Maximum Operating Temperature °C	Insulation Specification	Self Extinguishing Specification	Dimensions mm	Weight g	Quantity
(3 way) 1÷6	Z6-3	3	450	85	IP20	V-0 (UL 94)	23x23xh27,5	15,0	30
	Z6-3D						23x40xh36,5	18,5	10
(5 way) 1÷6	Z6-5	5	450	85	IP20	V-0 (UL 94)	35x23xh27,5	23,0	20
	Z6-5D						35x40xh36,5	26,5	10
(6 way) 1÷6	Z6-6	6	450	85	IP20	V-0 (UL 94)	23x43xh28,5	26,0	15
	Z6-6D						23x53xh33	31,0	10
(10 way) 1÷6	Z6-10	10	450	85	IP20	V-0 (UL 94)	35x43xh28,5	41,0	10
	Z6-10D						35x53xh33	46,0	15

D= Version with clamp for DIN rail

3, 5, 6 and 10 way, single pole terminal blocks for conductor section 1 to 6 sqmm.

Self contained and robust, they are quick and easy to install for both industrial and domestic use.

The indirect clamping of the "ZETApiù" terminal blocks guarantees a low and stable contact resistance. Indirect clamping eliminates damage to the conductor strands.

The easy-entry receptacles also grant a fast and reliable insertion of the cable.

Technical features:

- Self-extinguishing Polycarbonate body
- Tempered Steel clamps
- Electrolytically Tin plated Copper interconnections

Z16

SINGLE POLE TERMINAL BLOCKS

indirect clamping - nominal section 16 sqmm

type
ZETApiù®

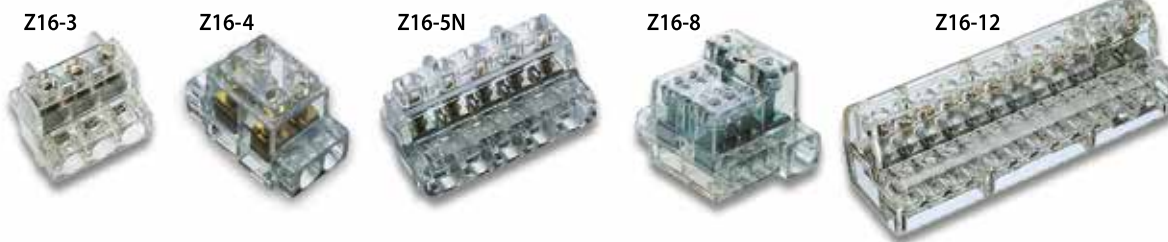

Connecting Capacity sqmm	Type	No. of Ways	Nominal Voltage V	Maximum Operating Temperature °C	Insulation Specification	Self Extinguishing Specification	Dimensions mm	Weight g	Quantity
16	Z16-3	3	450	85	IP20	V-0 (UL 94)	38x31,3xh38	52,0	20
	Z16-3D						38x50xh44	55,5	15
16	Z16-4	4	450	85	IP20	V-0 (UL 94)	27x54xh37	50,0	15
	Z16-4D						27x58xh43	54,0	10
16	Z16-5N	5	450	85	IP20	V-0 (UL 94)	61x31,5xh38	64,5	10
	Z16-5ND						61x50xh44	68,0	4
(2 way) 16 + (6 way) 6	Z16-8	8 (2÷6)	450	85	IP20	V-0 (UL 94)	35,5x50xh36,5	50,0	15
	Z16-8D						35,5x57xh42	56,0	10
(2 way) 16 + (10 way) 6	Z16-12	12 (2÷10)	450	85	IP20	V-0 (UL 94)	104,5x32,5xh36,5	115,0	8
	Z16-12D						104,5x50xh42	125,0	5

D= Version with clamp for DIN rail

3, 4, 5, 8 and 12 way, single pole terminal blocks.

Ideal for use as an equipotential bonding connector for both industrial and domestic use.

SINGLE POLE TERMINAL BLOCKS

indirect clamping - nominal section 35 sqmm

type
ZETApiù®

Z35-3



Z35-4



Z35-6



Connecting Capacity sqmm	Type	No. of Ways	Nominal Voltage V	Maximum Operating Temperature °C	Insulation Specification	Self Extinguishing Specification	Dimensions mm	Weight g	Quantity
35	Z35-3	3	450	85	IP20	V-0 (UL 94)	53x48,5xh42	110	10
	Z35-3D						53x50xh48	114	5
35	Z35-4	4	450	85	IP20	V-0 (UL 94)	37x85xh42	129	5
	Z35-4D						37x85xh48	133	5
(2 way) 35 + (4 way) 16	Z35-6	6 (2÷4)	450	85	IP20	V-0 (UL 94)	83x41xh43	130	8
	Z35-6D						83x49xh52	140	5

D= Version with clamp for DIN rail



3, 4 and 6 way, single pole terminal blocks. Ideal for use as an equipotential bonding connector for both industrial and domestic use.

SINGLE POLE TERMINAL BLOCKS

indirect clamping - for earthing applications ⊕

type
ZETApiù®

Z50-10D



Z35T-11
Z35T-11D



Z35-26D



Connecting Capacity sqmm	Type	No. of Ways	Maximum Operating Temperature °C	Self Extinguishing Specification	Dimensions mm	Weight g	Quantity
(1 way) 35 + (10 way) 6	Z35T-11	11	85	V-0 (UL 94)	58x43xh42	70	10
	Z35T-11D	(1+10)			58x53xh47	75	10
(2 way) 35 + (24 way) 10	Z35-26D	26 (2+24)	85	V-0 (UL 94)	151x52xh48	379	4
(2 way) 50 + (8 way) 25	Z50-10D	10 (2+8)	85	V-0 (UL 94)	77,5x55xh49	320	6

D= Version with clamp for DIN rail



























10, 11 and 26 way, single pole terminal blocks. Ideal for use as an equipotential bonding connector for both industrial and domestic use.

CONNECTING CAPACITY OF TERMINAL BLOCKS

indirect clamping

type
ZETApiù®

Type	Nominal Section	No. of Ways x Nominal Section	Connecting Capacity of Each Way* No. of Conductors x Section	Markings
Z6-3 Z6-3D	6 [□]	3 x 6 [□]		  6 sqmm 450 V T 85°C  
Z6-5 Z6-5D	6 [□]	5 x 6 [□]	1 x 6 [□] R/F 1 x 4 [□] R/F	
Z6-6 Z6-6D	6 [□]	6 x 6 [□]	1÷2 x 2,5 [□] R/F 1÷2 x 1,5 [□] R/F 1÷4 x 1 [□] R/F	  6 sqmm 450 V T 85°C  
Z6-10 Z6-10D	6 [□]	10 x 6 [□]		
Z16-3 Z16-3D	16 [□]	3 x 16 [□]	1 x 16 [□] R/F 1 x 10 [□] R/F 1÷2 x 6 [□] R/F 1÷3 x 4 [□] R/F 1÷4 x 2,5 [□] R/F 1÷8 x 1,5 [□] R/F	  16 sqmm 450 V T 85°C  
Z16-4 Z16-4D	16 [□]	4 x 16 [□]	1 x 16 [□] F 1 x 10 [□] F 1÷2 x 6 [□] F 1÷3 x 4 [□] F 1÷4 x 2,5 [□] F 1÷8 x 1,5 [□] F	
Z16-5N Z16-5ND	16 [□]	5 x 16 [□]	1 x 16 [□] R/F 1 x 10 [□] R/F 1÷2 x 6 [□] R/F 1÷3 x 4 [□] R/F 1÷4 x 2,5 [□] R/F 1÷8 x 1,5 [□] R/F	  16 sqmm 450 V T 85°C  
Z16-8 Z16-8D	16 [□] / 6 [□]	2 x 16 [□]	1 x 16 [□] R/F 1 x 10 [□] R/F 1÷2 x 6 [□] R/F 1÷3 x 4 [□] R/F 1÷4 x 2,5 [□] R/F 1÷8 x 1,5 [□] R/F	
		6 x 6 [□]	1 x 6 [□] R/F 1 x 4 [□] R/F 1÷2 x 2,5 [□] R/F 1÷2 x 1,5 [□] R/F 1÷4 x 1 [□] R/F	  16~6 sqmm 450 V T 85°C  
Z16-12	16 [□] / 6 [□]	2 x 16 [□]	1 x 16 [□] F 1 x 10 [□] F 1÷2 x 6 [□] F 1÷3 x 4 [□] F 1÷4 x 2,5 [□] F	
Z16-12D		10 x 6 [□]	1 x 6 [□] F 1 x 4 [□] F 1÷2 x 2,5 [□] F 1÷2 x 1,5 [□] F 1÷4 x 1 [□] F	  16~6 sqmm 450 V T 85°C  

* A mixture of conductor sizes may be connected to the terminal block provided that the sum of their sections is less than the nominal section.
R = Rigid conductor F = Flexible conductor

CONNECTING CAPACITY OF TERMINAL BLOCKS

indirect clamping

type
ZETApiù®

Type	Nominal Section	No. of Ways x Nominal Section	Connecting Capacity of Each Way* No. of Conductors x Section	Markings
Z35-3 Z35-3D	35 [□]	3 x 35 [□]	1 x 35 [□] R/F 1 x 25 [□] R/F 1÷2 x 16 [□] R/F 1÷3 x 10 [□] R/F 1÷5 x 6 [□] R/F	CE, Italian Institute of the Quality Mark, 35 sqmm 450 V T 85°C
Z35-4 Z35-4D	35 [□]	4 x 35 [□]	1 x 35 [□] F 1 x 25 [□] F 1÷2 x 16 [□] F 1÷3 x 10 [□] F 1÷6 x 6 [□] F	CE, Italian Institute of the Quality Mark, 35 sqmm 450 V T 85°C
Z35-6 Z35-6D	35 [□] / 16 [□]	2 x 35 [□]	1 x 35 [□] R/F 1 x 25 [□] R/F 1÷2 x 16 [□] R/F 1÷3 x 10 [□] R/F 1÷6 x 6 [□] F	CE, Italian Institute of the Quality Mark, 35~16 sqmm 450 V T 85°C, Lloyd's Register, Italian Naval Register
		4 x 16 [□]	1 x 16 [□] R/F 1 x 10 [□] R/F 1÷2 x 6 [□] R/F 1÷3 x 4 [□] R/F 1÷5 x 2,5 [□] F	
Z35T-11 Z35T-11D	35 [□] / 6 [□]	1 x 35 [□]	1 x 35 [□] R/F 1 x 25 [□] R/F 1 x 16 [□] R/F 1 x 10 [□] R/F	CE, Italian Institute of the Quality Mark, 35~6 sqmm T 85°C
		10 x 6 [□]	1 x 6 [□] R/F 1 x 4 [□] R/F 1÷2 x 2,5 [□] R/F 1÷2 x 1,5 [□] R/F 1÷4 x 1 [□] R/F	
Z35-26D	35 [□] / 10 [□]	2 x 35 [□]	1 x 35 [□] R/F 1 x 25 [□] R/F 1÷2 x 16 [□] R/F 1÷3 x 10 [□] R/F 1÷6 x 6 [□] R/F	CE, Italian Institute of the Quality Mark, 35~10 sqmm T 85°C, Lloyd's Register, Italian Naval Register
		24 x 10 [□]	1 x 10 [□] R/F 1 x 6 [□] R/F 1÷2 x 4 [□] R/F 1÷4 x 2,5 [□] R/F	
Z50-10D	50 [□] / 25 [□]	2 x 50 [□]	1 x 50 [□] R/F 1 x 35 [□] R/F 1÷2 x 25 [□] R/F 1÷4 x 16 [□] R/F	CE, Italian Institute of the Quality Mark, ** 50~25 sqmm T 85°C
		8 x 25 [□]	1 x 25 [□] R/F 1÷2 x 16 [□] R/F 1÷3 x 10 [□] R/F 1÷6 x 6 [□] R/F 1÷9 x 4 [□] R/F	

* A mixture of conductor sizes may be connected to the terminal block provided that the sum of their sections is less than the nominal section.
R = Rigid conductor F = Flexible conductor

MARKINGS



Italian Institute of the Quality Mark
type approval



Lloyd's Register of Shipping
type approval



Italian Naval Register
type approval



**
EN60947-1: 2007+A1: 2011: 2014
and EN 60947-7-1: 2002 Norms

Conforms to:

Directives 2014/35/UE

EN 60998-1: 2004 and
EN 60998-2-1: 2004 Norms

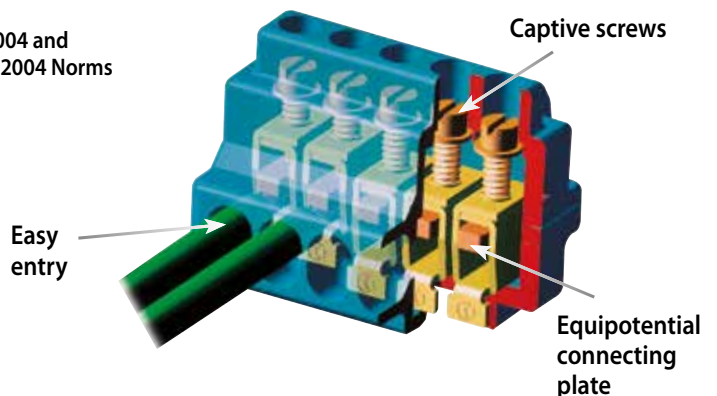

indirect clamping

type
ZETAblock®



Type	No. of poles	No. of Ways per pole	Nominal CSA for each pole sqmm	Maximum operating voltage (U _i)	Impulse voltage (U _{imp})	Maximum operating current (I _n)	Allowable short duration fault current (I _{cw})	Maximum allowed peak fault current (I _{pk})	Self Extinguishing Specification	Dimensions mm	Weight g	Qty
Z25-DP7-100	4	7 (2+5)	(2 way) 25 + (5 way) 6	800 V	8 kV	100 A	3 kA	18 kA	V-0 (UL 94)	70x84xh45	290	2
Z35-DP14-125	4	14 (2+2+10)	(2 way) 35 + (2 way) 16 + (10 way) 6	800 V	8 kV	125 A	4,2 kA	18 kA	V-0 (UL 94)	137x83xh46	700	1
Z35-DP14B-125	2	14 (2+2+10)	(2 way) 35 + (2 way) 16 + (10 way) 6	800 V	8 kV	125 A	4,2 kA	18 kA	V-0 (UL 94)	137x44xh46	360	2
Z50-DP12-160	4	12 (2+4+6)	(2 way) 50 + (4 way) 25 + (6 way) 16	800 V	8 kV	160 A	6 kA	18 kA	V-0 (UL 94)	150x84xh48	780	1

100, 125 and 160A, 2–4 pole distribution blocks with 7, 14 and 12 ways per pole respectively.

Accepting a wide cable CSA range (1 - 50 sqmm) and of compact size, Zeta-blocks are ideal for control cabinets and distribution panels.

The lateral arrangement of terminals on upper and lower faces (Z35-DP14B one face only), simplifies connection and promotes tidy, homogeneous cable routing to assist subsequent wiring operations.

Easy entry apertures provide quick, effective cable insertion while the indirect clamping feature eliminates damage to cable strands and assures a low, stable contact resistance.

Technical features:

- Self extinguishing antishock Polycarbonate body
- Tempered Steel captive clamping screws and plates
- Electrolytically Tin plated Copper interconnectors

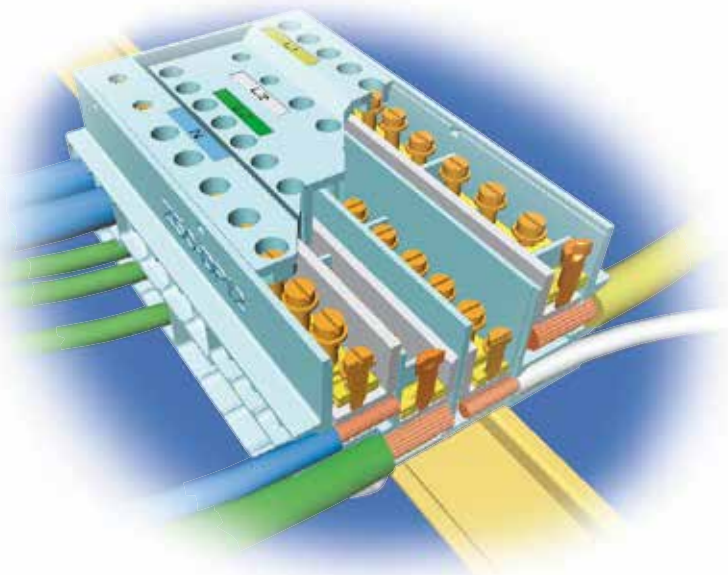

POWER DISTRIBUTION BLOCK

Z-DP





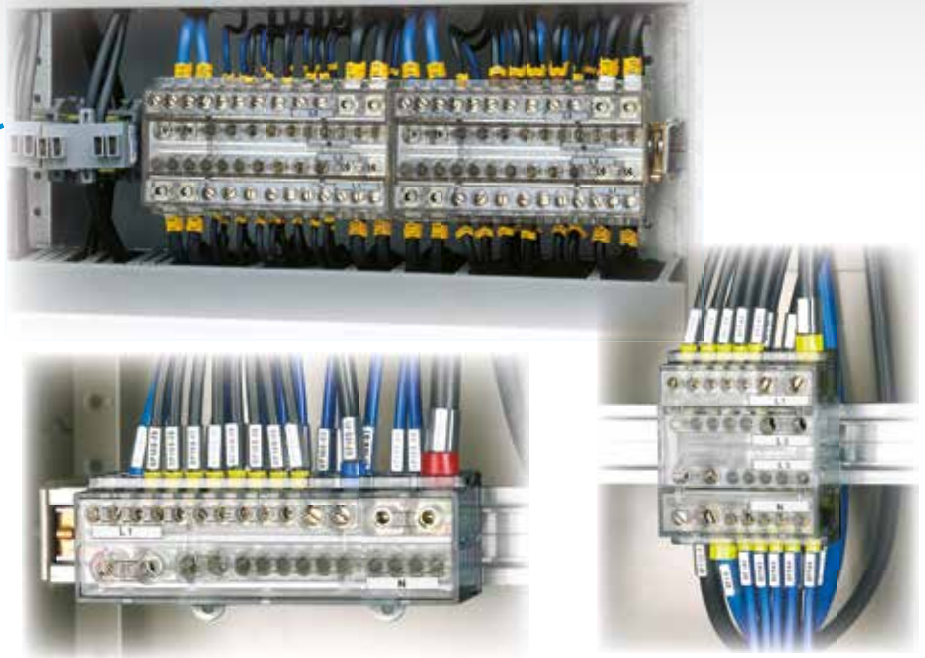

indirect clamping

type
ZETAblock®



CONNECTING CAPACITY OF POWER DISTRIBUTION BLOCK

indirect clamping

Type	Nominal Section	No. of Ways x Nominal Section	Connecting Capacity of Each Way No. of Conductors x Section	Markings
Z25-DP7-100	25□/6□	2 x 25□	1 x 25□ F 1 x 16□ F 1÷2 x 10□ F	  25÷6 sqmm
		5 x 6□	1 x 6□ F 1 x 4□ F 1÷2 x 2,5□ F 1÷2 x 1,5□ F 1÷4 x 1□ F	
Z35-DP14-125 Z35-DP14B-125	35□/16□/6□	2 x 35□	1 x 35□ F 1 x 25□ F 1÷2 x 16□ F 1÷3 x 10□ F	  35÷16÷6 sqmm
		2 x 16□	1 x 16□ F 1 x 10□ F 1÷2 x 6□ F 1÷3 x 4□ F 1÷4 x 2,5□ F	
		10 x 6□	1 x 6□ F 1 x 4□ F 1÷2 x 2,5□ F 1÷2 x 1,5□ F 1÷4 x 1□ F	
Z50-DP12-160	50□/25□/16□	2 x 50□	1 x 50□ F 1 x 35□ F 1÷2 x 25□ F	  50÷25÷16 sqmm
		4 x 25□	1 x 25□ F 1 x 16□ F 1÷2 x 10□ F	
		6 x 16□	1 x 16□ F 1 x 10□ F 1÷2 x 6□ F	

F = Flexible conductor

MARKINGS



Italian Institute of the Quality Mark
type approval

Conforms to:

Directives 2014/35/UE

EN 60947-7-1: 2009 Norms

indirect clamping



type
ZETAmini®



Connecting Capacity sqmm	Type	Nominal Voltage V	Maximum Operating Temperature °C	Insulation Specification	Self Extinguishing Specification	Dimensions mm	Weight g	Quantity
2,5	Z2.5-1	450	85	IP20	V-0 (UL 94)	7,6x20xh23,5	3	500/25
6	Z6-1	450	85	IP20	V-0 (UL 94)	11,5x28xh29	6	250/25
10	Z10-1	450	85	IP20	V-0 (UL 94)	15,6x32xh32,5	11	100/10
16	Z16-1	450	85	IP20	V-0 (UL 94)	18x34xh38	15	100/10
25	Z25-1	450	85	IP20	V-0 (UL 94)	20,8x42,5xh43,5	29	50/10
35	Z35-1	450	85	IP20	V-0 (UL 94)	25x45xh51,5	37	40/10

One way, single pole terminal blocks for conductors sections from 0.5 to 35 sqmm.

Self contained and robust, they are ideal for the fast and safe installation for industrial and domestic applications.

The indirect clamping of the "ZETAmini" terminal blocks guarantees a low and stable contact resistance.

The easy-entry receptacle also grants a fast and reliable insertion of the cable.

Technical features:

- Self-extinguishing Polycarbonate body
- Electrolytically Zinc plated, tempered Steel clamp and screw
- Electrolytically Tin plated Steel connection plate

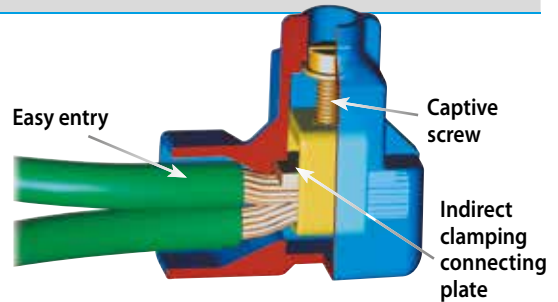

Type	Nominal Section	Connecting Capacity of Each Way* No. of Conductors x Section	Markings
Z2.5-1	2,5 [□]	2 x 2,5 [□] R/F 2 ÷ 3 x 1,5 [□] R/F 2 ÷ 5 x 1,0 [□] R/F 2 ÷ 6 x 0,75 [□] R/F 2 ÷ 10 x 0,5 [□] R/F 2 ÷ 18 x Ø 0,4 ÷ 0,6 mm communication type wire	CE, TÜV, 2,5 sqmm, 450V, T 85°C, IP 20, UL, CSA
Z6-1	6 [□]	2 x 6 [□] R/F 2 ÷ 3 x 4 [□] R/F 2 ÷ 4 x 2,5 [□] R/F 2 ÷ 6 x 1,5 [□] R/F 2 ÷ 6 x 1 [□] R/F 2 ÷ 10 x 0,75 [□] R/F 2 ÷ 12 x 0,5 [□] R/F (1 x 6 [□] F) + (4 x 1,5 [□] F) (1 x 6 [□] F) + (2 x 2,5 [□] F)	CE, TÜV, 6 sqmm, 450V, T 85°C, IP 20, UL, CSA
Z10-1	10 [□]	2 x 10 [□] R/F 2 ÷ 3 x 6 [□] R/F 2 ÷ 5 x 4 [□] R/F 2 ÷ 8 x 2,5 [□] R/F 2 ÷ 12 x 1,5 [□] R/F 2 ÷ 20 x 1 [□] R/F 2 ÷ 25 x 0,75 [□] R/F (1 x 6 [□] F) + (1 x 4 [□] F) + (2 x 2,5 [□] F) + (3 x 1,5 [□] F)	CE, TÜV, 10 sqmm, 450V, T 85°C, IP 20, UL, CSA
Z16-1	16 [□]	2 x 16 [□] R/F 2 ÷ 3 x 10 [□] R/F 2 ÷ 5 x 6 [□] R/F 2 ÷ 8 x 4 [□] R/F 2 ÷ 12 x 2,5 [□] R/F 2 ÷ 18 x 1,5 [□] R/F	CE, TÜV, 16 sqmm, 450V, T 85°C, IP 20, UL, CSA
Z25-1	25 [□]	2 x 25 [□] R/F 2 ÷ 3 x 16 [□] R/F 2 ÷ 4 x 10 [□] R/F 2 ÷ 8 x 6 [□] R/F 2 ÷ 11 x 4 [□] R/F 4 ÷ 16 x 2,5 [□] R/F	CE, TÜV, 25 sqmm, 450V, T 85°C, IP 20, UL, CSA
Z35-1	35 [□]	2 x 35 [□] R/F 2 ÷ 3 x 25 [□] R/F 2 ÷ 4 x 16 [□] R/F 2 ÷ 7 x 10 [□] R/F 2 ÷ 11 x 6 [□] R/F 4 ÷ 17 x 4 [□] R/F 5 ÷ 28 x 2,5 [□] R/F	CE, TÜV, 35 sqmm, 450V, T 85°C, IP 20, UL, CSA

*A mixture of conductor sizes may be connected to the terminal block provided that the sum of their sections is less than twice the nominal section.

R = Rigid conductor F = Flexible conductor

Conforms to:

Directives 2014/35/UE

EN 60998-1: 2004 and
EN 60998-2-1: 2004 Norms

TERMINAL BLOCK TYPE EKL

EKL

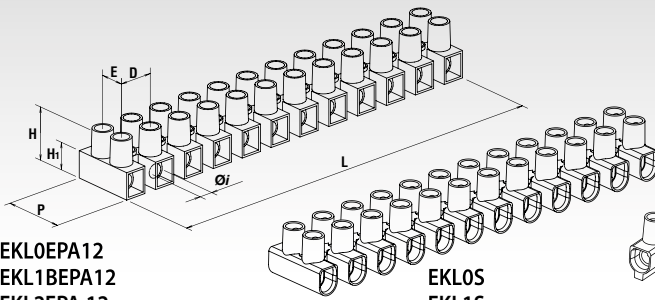

EKLOEPA12
EKL1BEPA12
EKL2EPA 12
EKL3EM4PA12

EKLOS
EKL1S
EKL2S
EKL3S

EKL4BEPA12
EKL4BESVCE

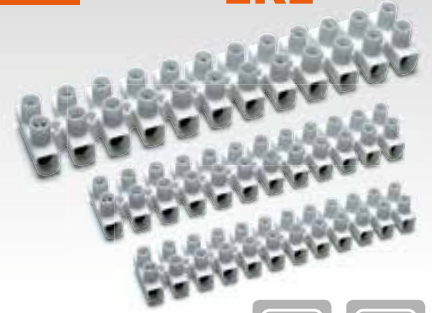

Type 12 Poles of Polyamide (PA6)

Type	Nominal section sqmm	Dimensions mm								Screw	Quantity
		Øi	L 12 poles	H	H1	P	E	D			
△ EKLOEPA12	2,5	2,8	94,0	13,4	7,6	16,2	6,4	8,0	M2,6	50	
△ EKL1BEPA12	4	3,5	117,0	15,0	7,7	18,6	7,3	10,0	M3	30	
△ EKL2EPA12	6	4,2	133,7	17,3	8,8	22,2	10,0	11,5	M3,5	15	
□ EKL3EM4PA12	16	5,8	175,0	20,8	11,4	25,2	11,0	15,0	M4	25	
○ EKL4BEPA12	25	7,0	187,3	28,0	15,5	30,0	11,0	16,0	M5	25	

Type 12 Poles of Polypropylene (PP)

Type	Nominal section sqmm	Dimensions mm								Screw	Quantity
		Øi	L 12 poles	H	H1	P	E	D			
● EKLOS	4	3,2	94,9	13,0	-	16,6	6,4	8,1	M2,6	50	
● EKL1S	6	3,5	116,5	14,9	-	18,9	7,3	10,0	M3	30	
● EKL2S	10	4,3	133,8	17,3	-	23,4	10,0	11,5	M3,5	15	
● EKL3S	16	5,5	174,5	25,0	-	20,7	11,0	15,0	M4	25	
○ EKL4BESVCE	25	7,0	187,3	28,0	-	30,0	11,0	16,0	M5	25	

- △ Nominal voltage : 450 V
Ambient temperature : max 85°C
Test temperature EN 60998: 115°C
- Nominal voltage : 450 V
Ambient temperature: max 110°C
Test temperature EN 60998: 140°C

- Nominal voltage: 750 V
Ambient temperature: max 80°C
Test temperature: EN 60998: 140°C
- Nominal voltage: 450 V
Ambient temperature: max 80°C

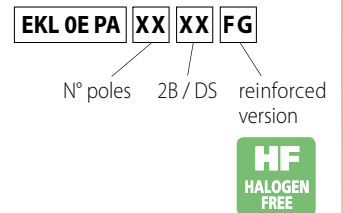

TERMINAL BLOCK TYPE ZS

ZS

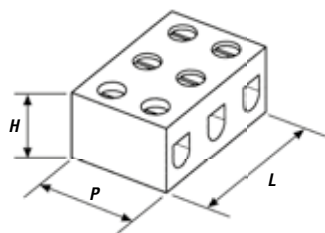

Type	Nominal section sqmm		No. of poles	Dimensions mm				Quantity
	Low Str.	Flex		Øi	L	H	P	
ZS-U6	4/6	4	1	3	9	18	19	200
ZS-B6	4/6	4	2	3	22	18	19	80
ZS-T6	4/6	4	3	3	36	18	19	60
ZS-U10	10	6	1	4	13	20	21	200
ZS-B10	10	6	2	4	24	20	21	80
ZS-T10	10	6	3	4	36	20	21	70
ZS-U16	16	10	1	6	15	22	27	100
ZS-B16	16	10	2	6	31	22	27	50
ZS-T16	16	10	3	6	48	22	27	30



- Material:**
- insulating body in STEATITE
 - screw in GALVANIZED STEEL
 - BRASS clamp

Nominal voltage: 450 V
Operating temperature: 300°C



Designation

SFI	8	x 24	x 1
Insulated flexible busbar	Number of strips	Strip width mm	Strip thickness mm

Advantages

Insulated flexible busbar is a self-contained system combining convenient layout and connection with assured insulation and self-supporting construction, resulting in reduced cost installations with extreme ease of use.

Compared to plain busbar:

- Higher current capacity size for size
- Space saving as individual insulated busbars may be positioned in closer proximity
- Layout easier and quicker due to flexibility
- Insulated support not required.

Compared to cables:

- Simple and rapid installation
- Space saving due to tighter bend radius
- Insulated support not required.

Principle of selection

The following charts allow selection of the appropriate configuration based on:

- ambient temperature of 35°C
- required current carrying capacity in Amps
- maximum permitted temperature increase

Example of selection

Required current carrying capacity per phase is 630A.

Maximum permitted temperature in the equipment enclosure is 85°C:

- ambient temperature is 35°C
- maximum permitted temperature rise is 85°C - 35°C = 50°C

The possible selections are where the red vertical line (630A) intersects the green temperature band (50°C):

SFI8X24X1
SFI6X32X1
SFI4X40X1

The final selection will depend on limitations relating to connection palm width.

Technical features

PVC Insulation (for width 9 - 50mm):

- Density: 1,31 g/cm³
- Hardness Shore: 85A
- Breaking resistance: 19,6 MPa
- Breaking elongation: 365%
- Thermal conductivity: 3÷4 10⁻⁴ cal/s/cm²°C
- Dielectric strength: 20 kV/mm
- Self-extinguishing class: Vo (UL 94)

Strip:

- Copper designation: Cu-ETP
- Copper purity min: 99,9%
- Max electrical resistivity at 20°C: 1,7241 μΩ/cm (100% IACS)
- Breaking resistance min: 200MPa
- Breaking elongation min: 30%
- Hardness: <55 HV

Insulated flexible busbar:

- max working voltage: 1000 V
- Working temperature: -40°C ÷ +105°C
- Average thickness of extruded PVC: 2mm
- Average dielectric strength: 20kV/mm

Total conductor c.s.a. sqmm	Type
21,6	SFI3X9X0.8
43,2	SFI6X9X0.8
13,0	SFI2X13X0.5
19,5	SFI3X13X0.5
26	SFI4X13X0.5
39	SFI6X13X0.5
37,2	SFI3X15.5X0.8
49,6	SFI4X15.5X0.8
74,4	SFI6X15.5X0.8
124	SFI10X15.5X0.8
40	SFI2X20X1
60	SFI3X20X1
80	SFI4X20X1
100	SFI5X20X1
120	SFI6X20X1
160	SFI8X20X1
48	SFI2X24X1
72	SFI3X24X1
96	SFI4X24X1
120	SFI5X24X1
144	SFI6X24X1
192	SFI8X24X1
240	SFI10X24X1
64	SFI2X32X1
96	SFI3X32X1
128	SFI4X32X1
160	SFI5X32X1
192	SFI6X32X1
256	SFI8X32X1
320	SFI10X32X1
160	SFI4X40X1
200	SFI5X40X1
240	SFI6X40X1
320	SFI8X40X1
400	SFI10X40X1
200	SFI4X50X1
250	SFI5X50X1
300	SFI6X50X1
400	SFI8X50X1
500	SFI10X50X1
315	SFI5X63X1
378	SFI6X63X1
504	SFI8X63X1
630	SFI10X63X1
320	SFI4X80X1
400	SFI5X80X1
480	SFI6X80X1
640	SFI8X80X1
800	SFI10X80X1
500	SFI5X100X1
600	SFI6X100X1
800	SFI8X100X1
1000	SFI10X100X1
1200	SFI12X100X1



Concept and design

Cembre SFI series insulated flexible busbar comprises a set of Cu strips within an insulated sleeve - for widths 9-50mm this is extruded PVC, for widths 63-100mm it is heat shrunk material.

The dielectric strength of the insulation is guaranteed independent of the eventual formation of the busbar and its working conditions (humidity, temperature and environmental aggressors).

Dimensions

Standard length:
2000 mm (consult us for other lengths)

Strip thickness:
0,5 - 1 mm

Number of strips:
2 - 12.

Applications

- Power distribution, substituting cable with extruded insulation and rigid busbar
- Electrical equipment (racks, circuit breakers, rectifiers)
- Transformers

Current carrying capacity (A)

Temperature increase for each configuration based on an ambient temperature of 35°C

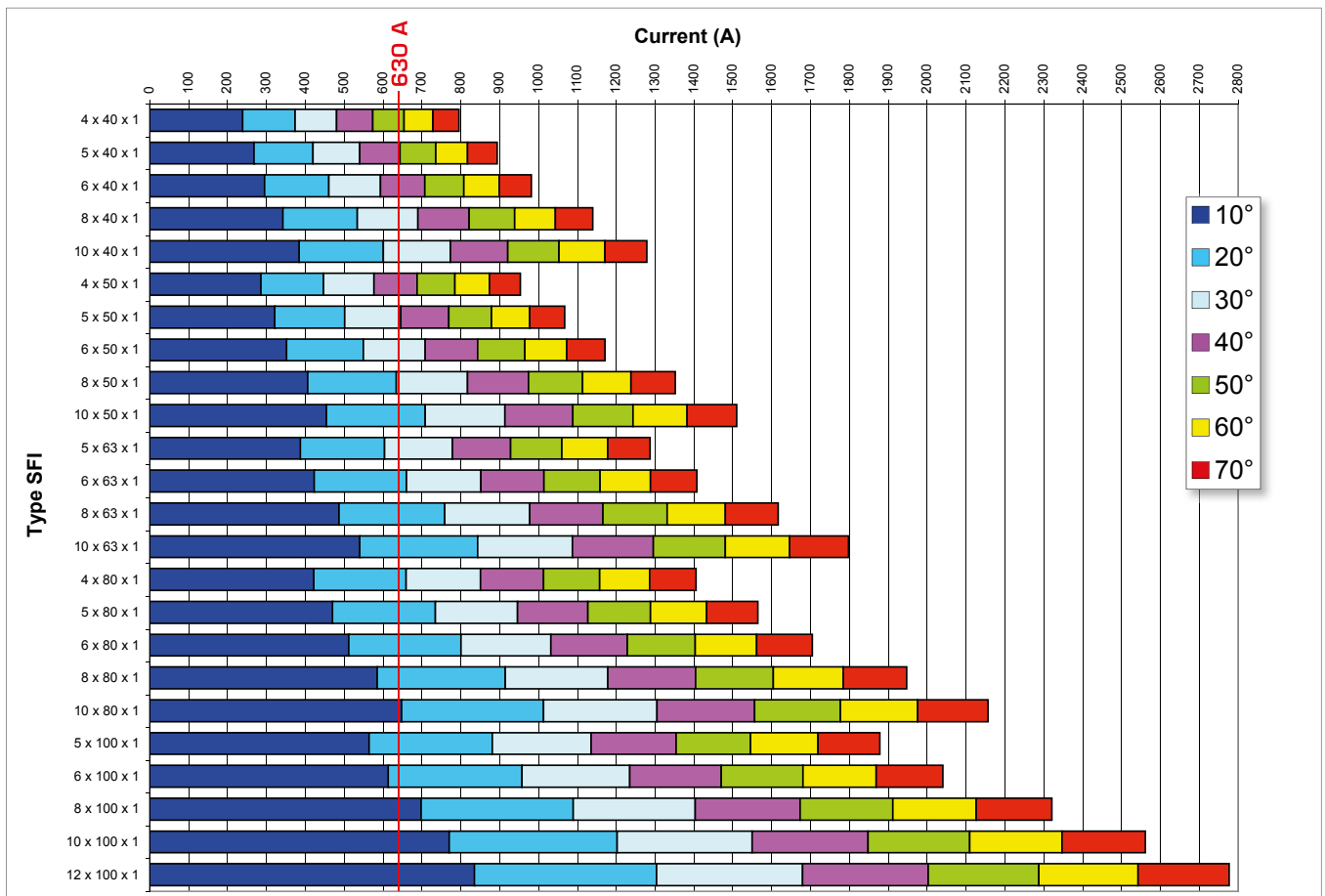
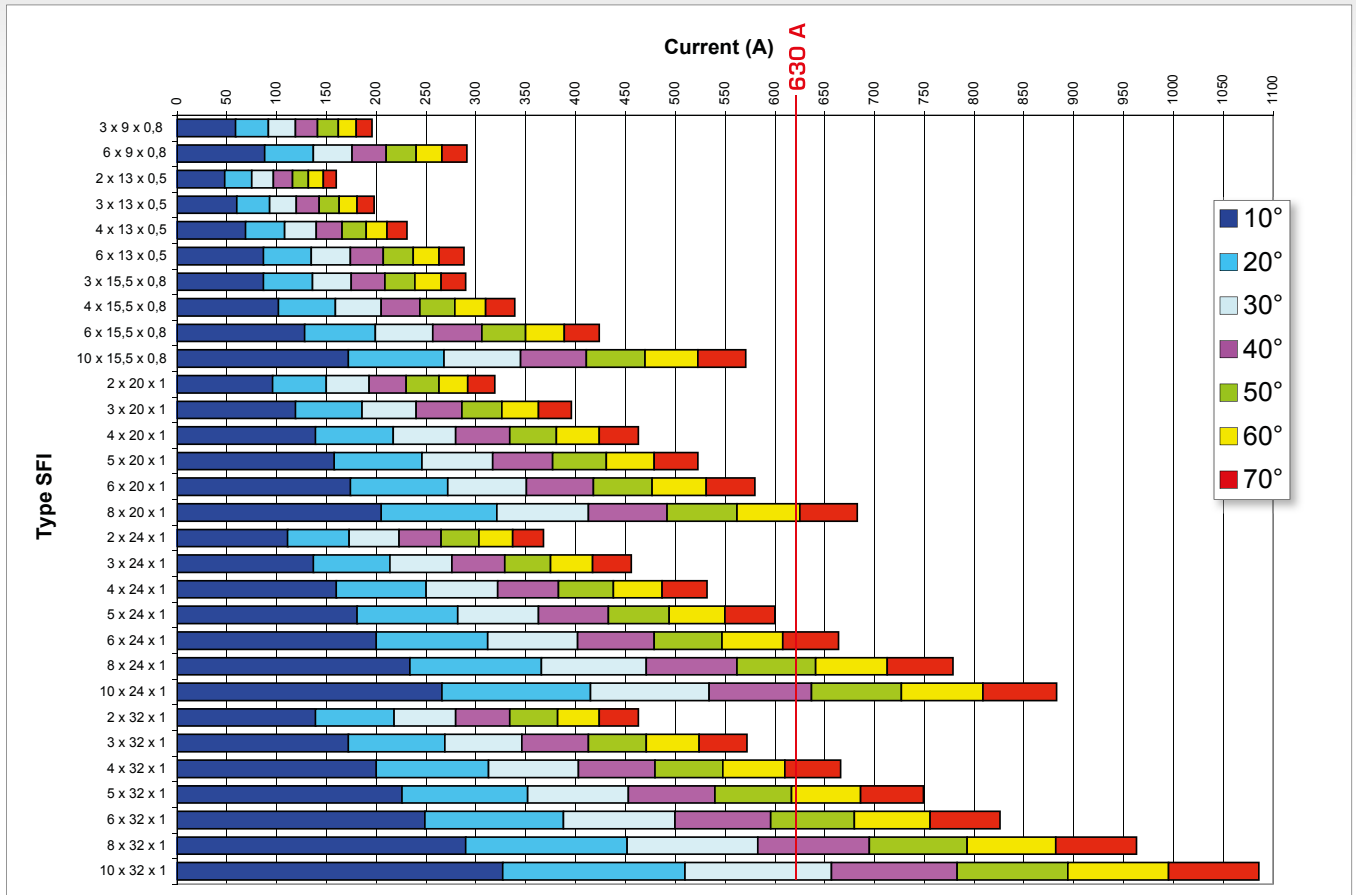

Mechanical bending and torsion testing

Test temperatures: -10°C and +80°C.

Bending 180°

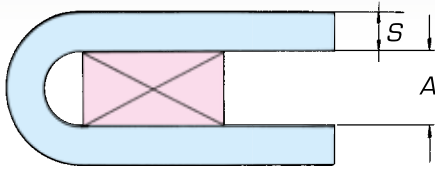

S = Bar thickness (conductor + insulation)
A = 2 x S

Torsion 90°

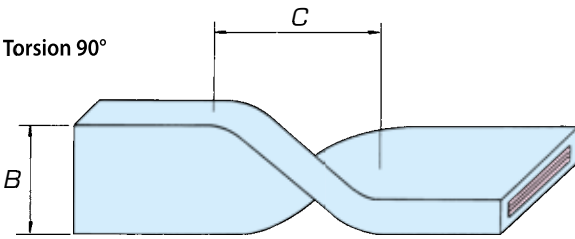

B = Bar width (conductor + insulation)
C = 1,5 x B

In both cases the tests do not show damage to the insulation



Insulated flexible busbar installation

Bending:

Small section configurations may be bent manually. When tooling is used, protect the insulated sleeve of the busbar from damage. As the Cu strips move relative to each other during bending, this operation

Drilling:

Drilling templates type **MFB 13-40** and type **MFB 50-63** (available as optional extras) are designed to facilitate accurate location of fixing holes in the busbar of Ø 8, 10, 12 mm. It is recommended that the insulation of the busbar is not removed before drilling is completed, as it assists the operation.

Template type	includes drilling inserts	for bar width mm
MFB 13-40	SFB13-16	for bar width 13÷15,5 mm
	SFB20-24	for bar width 20÷24 mm
	SFB32-40	for bar width 32÷40 mm
MFB 50-63	SFB50-63	for bar width 50÷63 mm



Flexible braids are manufactured from electrolytic Copper wire. Braids of different conductor sizes or lengths are available on request. Standard finish - bright Copper. Flexible braids can be supplied Tin plated, in this case add the suffix "ST" to reference.

E.g.:
- FL 10-150 (Bright Copper)
- FL 10-150-ST (Tin plated)

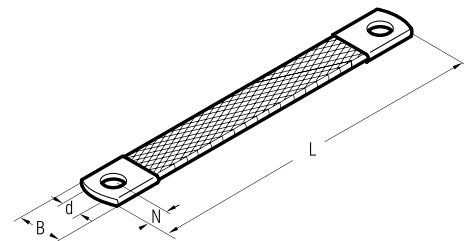

Size sqmm	Ø Stud mm	Type	Dimensions mm				Quantity
			B	N	L	d	
10	8	FL10-150	17	10	150	8,5	50
	8	FL10-200	17	10	200	8,5	50
	8	FL10-250	17	10	250	8,5	50
16	8	FL16-150	17	10	150	8,5	50
	8	FL16-200	17	10	200	8,5	50
	8	FL16-250	17	10	250	8,5	50
	8	FL16-320	17	10	320	8,5	50
	8	FL16-350	17	10	350	8,5	50
	8	FL16-420	17	10	420	8,5	25
25	8	FL16-570	17	10	570	8,5	25
	8	FL16-660	17	10	660	8,5	25
	8	FL25-150	21	10	150	8,5	50
	8	FL25-200	21	10	200	8,5	50
	8	FL25-250	21	10	250	8,5	50
	8	FL25-300	21	10	300	8,5	50



CABLE GLANDS AND ACCESSORIES

symbol description

cable glands and accessories

PA 6.6

Polyamide PA6.6 body



Operating temperature range

PA 6

Polyamide PA6 body



Degree of protection

NEOPRENE

Neoprene material



V2 UL94 self-extinguishing class

PS

Polystyrene body



VDE marking

BRASS

Brass body



ATEX marking



Protected by Nickel plated to avoid oxidation



USL-CNL Marking valid in USA & CANADA

STAINLESS STEEL

Stainless steel body



USR-CNR Marking valid in USA & CANADA

STEEL
ZINC PLATED

Galvanized Steel body



CE Marking

NBR

Nitrile-butadiene material



Halogen Free

PVC

Polyvinylchloride material

EPDM

EPDM rubber material

ABS

ABS material



MAXIblock®



POLYAMIDE CABLE GLANDS
WITH PROTECTION IP 68

*spiral*block®



POLYAMIDE CABLE GLANDS
WITH PROTECTION IP 68

MAXIbrass®



NICKEL PLATED BRASS CABLE GLANDS
WITH PROTECTION IP 68

MAXIinox



STAINLESS STEEL CABLE GLANDS
WITH PROTECTION IP 68

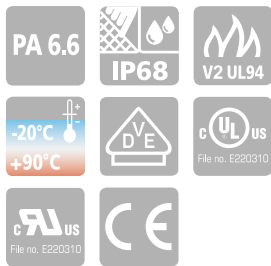

Material: POLYAMIDE PA6.6
 self-extinguishing class V2 (UL 94)
 Temperature range:
 -20°C to +90°C (continuous)
 Sealing ring: NEOPRENE® 50 sh A
 Protection: IP 68
 Colour: RAL 7035 light grey,
 RAL 9005 black, RAL 7001 dark grey

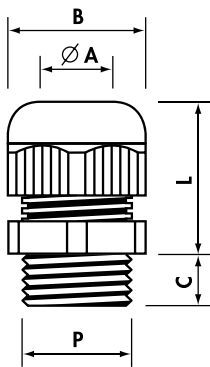

standard

Metric thread M 1.5 pitch CEI EN 60423 CEI EN 62444

Type Light Grey	P	Fixing Hole Ø (mm)	Ø A min-max (mm)	B Spanner (mm)	C (mm)	L min-max (mm)	Quantity
1900.M12	M12x1,5	12,2	3,5- 7	15	8	18-22	100
1900.M16	M16x1,5	16,2	5 -10	19	8	22-27	100
1900.M20	M20x1,5	20,5	7 -13	25	9	24-30	100
1900.M25	M25x1,5	25,4	10 -17	30	10	28-39	50
1900.M32	M32x1,5	32,5	13 -21	36	10	33-44	25
1900.M40	M40x1,5	40,5	19 -28	46	10	36-45	15
1900.M50	M50x1,5	50,5	27 -35	55	12	43-52	10
1900.M63	M63x1,5	64,0	34 -45	66	12	45-55	5

Add to Ref: N for Black, G for Dark Grey

reduced cable entry

Metric thread M 1.5 pitch CEI EN 60423 CEI EN 62444

Type Light Grey	P	Fixing Hole Ø (mm)	Ø A min-max (mm)	B Spanner (mm)	C (mm)	L min-max (mm)	Quantity
1910.M12	M12x1,5	12,2	2- 5	15	8	18-22	100
1910.M16	M16x1,5	16,2	3- 7	19	8	22-27	100
1910.M20	M20x1,5	20,5	5-10	25	9	24-30	100
1910.M25	M25x1,5	25,4	7-13	30	10	28-39	50
1910.M32	M32x1,5	32,5	8-14	36	10	33-44	25
1910.M40	M40x1,5	40,5	15-23	46	10	36-45	15
1910.M50	M50x1,5	50,5	20-29	55	12	43-52	10
1910.M63	M63x1,5	64,0	27-39	66	12	45-55	5

Add to Ref: N for Black, G for Dark Grey

extended thread

Metric thread M 1.5 pitch CEI EN 60423 CEI EN 62444

Type Light Grey	P	Fixing Hole Ø (mm)	Ø A min-max (mm)	B Spanner (mm)	C (mm)	L min-max (mm)	Quantity
1901.M12	M12x1,5	12,2	3,5- 7	15	15	18-22	100
1901.M16	M16x1,5	16,2	5 -10	19	15	22-27	100
1901.M20	M20x1,5	20,5	7 -13	25	15	24-30	50
1901.M25	M25x1,5	25,4	10 -17	30	15	30-41	50
1901.M32	M32x1,5	32,5	13 -21	36	15	33-44	25
1901.M40	M40x1,5	40,5	19 -28	46	18	36-45	15
1901.M50	M50x1,5	50,5	27 -35	55	18	43-52	10
1901.M63	M63x1,5	64,0	34 -45	66	18	45-55	5

Add to Ref: N for Black, G for Dark Grey

MAXIBLOCK CABLE GLANDS

1900

Polyamide PA6.6

MAXIblock[®]

standard

Pg thread DIN 40 430

Type Light Grey	P	Fixing Hole Ø (mm)	Ø A min-max (mm)	B Spanner (mm)	C (mm)	L min-max (mm)	Quantity
1900.07	Pg 7	12,7	3,5- 7	15	8	18-22	100
1900.09	Pg 9	15,5	5 - 8	19	8	22-26	100
1900.11	Pg11	18,8	5 -10	22	8	23-28	100
1900.13	Pg13,5	20,5	7 -12	24	9	24-29	100
1900.16	Pg16	22,6	10 -14	27	10	26-31	50
1900.21	Pg21	28,5	13 -18	33	12	30-35	50
1900.29	Pg29	37,2	18 -25	42	12	33-39	25
1900.36	Pg36	47,2	20 -32	53	14	42-49	10
1900.42	Pg42	54,2	28 -38	60	14	42-50	5
1900.48	Pg48	60,0	37 -45	66	15	45-55	5

Add to Ref: N for Black, G for Dark Grey

reduced cable entry

Pg thread DIN 40 430

Type Light Grey	P	Fixing Hole Ø (mm)	Ø A min-max (mm)	B Spanner (mm)	C (mm)	L min-max (mm)	Quantity
1910.07	Pg 7	12,7	2- 5	15	8	18-22	100
1910.09*	Pg 9	15,5	2- 6	19	8	22-26	100
1910.11	Pg11	18,8	4- 7	22	8	23-28	100
1910.13	Pg13,5	20,5	5-10	24	9	24-29	100
1910.16*	Pg16	22,6	6-12	27	10	26-31	50
1910.21	Pg21	28,5	9-15	33	12	30-35	50
1910.29*	Pg29	37,2	12-20	42	12	33-39	25
1910.36	Pg36	47,2	18-26	53	14	42-49	10
1910.42	Pg42	54,2	25-31	60	14	42-50	5
1910.48*	Pg48	60,0	27-39	66	15	45-55	5

Add to Ref: N for Black

extended thread

Pg thread DIN 40 430

Type Light Grey	P	Fixing Hole Ø (mm)	Ø A min-max (mm)	B Spanner (mm)	C (mm)	L min-max (mm)	Quantity
1901.07	Pg 7	12,7	3,5- 7	15	15	18-22	100
1901.09	Pg 9	15,5	5 - 8	19	15	22-26	100
1901.11	Pg11	18,8	5 -10	22	15	23-28	100
1901.13	Pg13,5	20,5	7 -12	24	15	24-29	100
1901.16	Pg16	22,6	10 -14	27	15	26-31	50
1901.21	Pg21	28,5	13 -18	33	15	30-35	50
1901.29	Pg29	37,2	18 -25	42	15	33-39	25
1901.36	Pg36	47,2	20 -32	53	18	42-49	10
1901.42	Pg42	54,2	28 -38	60	18	42-50	5
1901.48	Pg48	60,0	37 -45	66	18	45-55	5

Add to Ref: N for Black

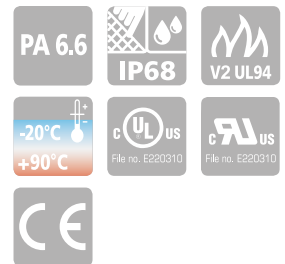

Material: POLYAMIDE PA6.6
self-extinguishing class V2 (UL 94)
Temperature range:
-20°C to +90°C (continuous)
Sealing ring: NEOPRENE® 50 sh A
Protection: IP 68
Colour: RAL 7035 light grey,
RAL 9005 black, RAL 7001 dark grey

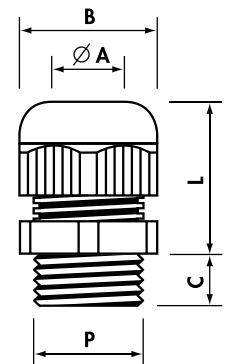

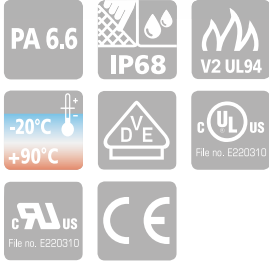

Material: POLYAMIDE PA6.6
 self-extinguishing class V2 (UL 94)
 Temperature range:
 -20°C to +90°C (continuous)
 Sealing ring: NEOPRENE® 50 sh A
 Protection: IP 68
 Colour: RAL 7035 light grey

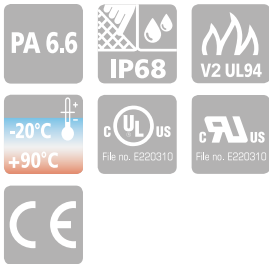

standard, factory fitted with locknuts with collar

Metric thread M 1.5 pitch CEI EN 60423 CEI EN 62444

Type	P	Fixing Hole Ø (mm)	Ø A min-max (mm)	B Spanner (mm)	C (mm)	L min-max (mm)	Quantity Box/Bag
1900.M12/X	M12x1,5	12,2	3,5- 7	15	8	18-22	100/10
1900.M16/X	M16x1,5	16,2	5 -10	19	8	22-27	100/10
1900.M20/X	M20x1,5	20,5	7 -13	25	9	24-30	50/10
1900.M25/X	M25x1,5	25,4	10 -17	30	10	28-39	30/10
1900.M32/X	M32x1,5	32,5	13 -21	36	10	33-44	20/10
1900.M40/X	M40x1,5	40,5	19 -28	46	10	36-45	10/5
1900.M50/X	M50x1,5	50,5	27 -35	55	12	43-52	5/5
1900.M63/X	M63x1,5	64,0	34 -45	66	12	45-55	5/5

standard, factory fitted with locknuts with collar

Pg thread DIN 40 430

Type	P	Fixing Hole Ø (mm)	Ø A min-max (mm)	B Spanner (mm)	C (mm)	L min-max (mm)	Quantity Box/Bag
1900.07/X	Pg 7	12,7	3,5- 7	15	8	18-22	100/10
1900.09/X	Pg 9	15,5	5 - 8	19	8	22-26	100/10
1900.11/X	Pg11	18,8	5 -10	22	8	23-28	50/10
1900.13/X	Pg13,5	20,5	7 -12	24	9	24-29	50/10
1900.16/X	Pg16	22,6	10 -14	27	10	26-31	30/10
1900.21/X	Pg21	28,5	13 -18	33	12	30-35	20/10
1900.29/X	Pg29	37,2	18 -25	42	12	33-39	20/10
1900.36/X	Pg36	47,2	20 -32	53	14	42-49	10/5
1900.42/X	Pg42	54,2	28 -38	60	14	42-50	5/5
1900.48/X	Pg48	60,0	37 -45	66	15	45-55	5/5

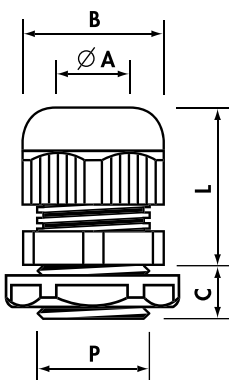

MAXIBLOCK CABLE GLANDS

Polyamide PA6.6

MAXIblock®

standard, factory fitted with Polyethylene foam discs

Metric thread M 1.5 pitch CEI EN 60423 CEI EN 62444

Type	P	Fixing Hole Ø (mm)	Ø A min-max (mm)	B Spanner (mm)	C (mm)	L min-max (mm)	Quantity
1900DP.M12	M12x1,5	12,2	3,5- 7	15	8	18-22	100
1900DP.M16	M16x1,5	16,2	5 -10	19	8	22-27	100
1900DP.M20	M20x1,5	20,5	7 -13	25	9	24-30	100
1900DP.M25	M25x1,5	25,4	10 -17	30	10	28-39	50
1900DP.M32	M32x1,5	32,5	13 -21	36	10	33-44	25
1900DP.M40	M40x1,5	40,5	19 -28	46	10	36-45	15
1900DP.M50	M50x1,5	50,5	27 -35	55	12	43-52	10
1900DP.M63	M63x1,5	64,0	34 -45	66	12	45-55	5

Pg thread DIN 40 430

Type	P	Fixing Hole Ø (mm)	Ø A min-max (mm)	B Spanner (mm)	C (mm)	L min-max (mm)	Quantity
1900DP.07	Pg 7	12,7	3,5- 7	15	8	18-22	100
1900DP.09	Pg 9	15,5	5 - 8	19	8	22-26	100
1900DP.11	Pg11	18,8	5 -10	22	8	23-28	100
1900DP.13	Pg13,5	20,5	7 -12	24	9	24-29	100
1900DP.16	Pg16	22,6	10 -14	27	10	26-31	50
1900DP.21	Pg21	28,5	13 -18	33	12	30-35	50
1900DP.29	Pg29	37,2	18 -25	42	12	33-39	25
1900DP.36	Pg36	47,2	20 -32	53	14	42-49	10
1900DP.42	Pg42	54,2	28 -38	60	14	42-50	5
1900DP.48	Pg48	60,0	37 -45	66	15	45-55	5

MAXIBLOCK CABLE GLANDS

Polyamide PA6.6

BSP thread ISO 228/1

Type Light Grey	P	Fixing Hole Ø (mm)	Ø A min-max (mm)	B Spanner (mm)	C (mm)	L min-max (mm)	Quantity
1900.14	G1/4"	13,5	3- 6,5	15	8	18-22	100
1900.38	G3/8"	17,0	4- 8	19	8	22-26	100
1900.12	G1/2"	21,5	7-12	24	10	24-29	100
1900.34	G3/4"	27,0	13-18	33	12	30-35	50

Add to Ref: N for Black

Material: POLYAMIDE PA6.6
self-extinguishing class V2 (UL 94)
Temperature range:
-20°C to +90°C (continuous)
Sealing ring: NEOPRENE® 50 sh A
Protection: IP 68
Colour: RAL 7035 light grey,
RAL 9005 black

1900DP



Material: POLYAMIDE PA6.6
self-extinguishing class V2 (UL 94)
Temperature range:
-20°C to +90°C (continuous)
Sealing ring: NEOPRENE® 50 sh A
Protection: IP 68
Colour: RAL 7035 light grey
Discs: 2 mm thick Polyethylene foam

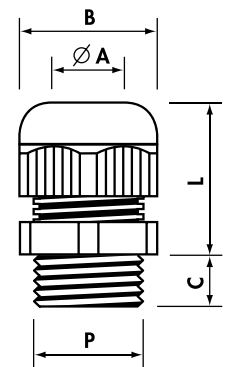

1900

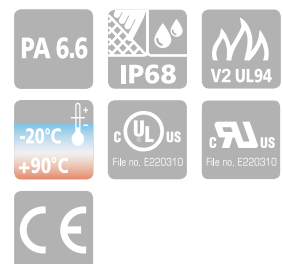

1500

SPIRALBLOCK CABLE GLANDS

Polyamide PA6.6

spiralblock®



Metric thread M 1.5 pitch CEI EN 60423 CEI EN 62444



Type Light Grey	P	Fixing Hole Ø (mm)	Ø A min-max (mm)	B Spanner (mm)	C (mm)	L max (mm)	Quantity
1500.M12	M12x1,5	12,2	3,5- 7	15	8	57	100
1500.M16	M16x1,5	16,2	5 -10	19	8	79	50
1500.M20	M20x1,5	20,5	7 -13	25	9	90	25
1500.M25	M25x1,5	25,4	10 -17	30	10	120	20
1500.M32	M32x1,5	32,5	13 -21	36	10	140	10

Add to Ref: N for Black

Pg thread DIN 40 430

Type Light Grey	P	Fixing Hole Ø (mm)	Ø A min-max (mm)	B Spanner (mm)	C (mm)	L max (mm)	Quantity
1500.07	Pg 7	12,7	3,5- 7	15	8	57	100
1500.09	Pg 9	15,5	5 - 8	19	8	68	100
1500.11	Pg11	18,8	5 -10	22	8	80	50
1500.13	Pg13,5	20,5	7 -12	24	10	90	50
1500.16	Pg16	22,6	10 -14	27	10	100	25
1500.21	Pg21	28,5	13 -18	33	12	112	20

Add to Ref: N for Black

BSP thread ISO 228/1

Type Light Grey	P	Fixing Hole Ø (mm)	Ø A min-max (mm)	B Spanner (mm)	C (mm)	L max (mm)	Quantity
1500.14	G1/4"	13,5	3- 6,5	15	8	57	100
1500.38	G3/8"	17,0	4- 8	19	9	68	100
1500.12	G1/2"	21,5	7-12	24	10	90	50
1500.34	G3/4"	27,0	13-18	33	12	112	20

Add to Ref: N for Black

Material: POLYAMIDE PA6.6
self-extinguishing class V2 (UL 94)
Temperature range:
-20°C to +90°C (continuous)
Sealing ring: NEOPRENE® 50 sh A
Protection: IP 68
Colour: RAL 7035 light grey,
RAL 9005 black

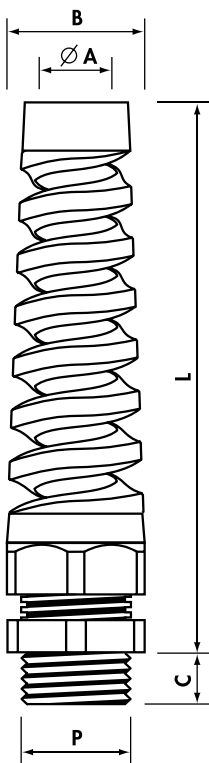

MAXIBLOCK ATEX CABLE GLANDS

4900

Polyamide PA6.6

MAXIblock[®]

Metric thread M 1.5 pitch CEI EN 60423 CEI EN 62444



Type Light Grey	P	Fixing Hole Ø (mm)	Ø A min-max (mm)	B Spanner (mm)	C (mm)	L min-max (mm)	Quantity
4900.M12	M12x1,5	12,2	3,5- 6,5	15	8	18-22	100
4900.M16	M16x1,5	16,2	6,5-10	19	8	22-27	100
4900.M20	M20x1,5	20,5	9 -13	25	9	24-30	100
4900.M25	M25x1,5	25,4	11 -17	30	10	28-39	50
4900.M32	M32x1,5	32,5	16 -21	36	10	33-44	25
4900.M40	M40x1,5	40,5	21 -28	46	10	36-45	15
4900.M50	M50x1,5	50,5	27 -35	55	12	43-52	10
4900.M63	M63x1,5	64,0	35 -42	66	12	45-55	5

extended thread

Type Light Grey	P	Fixing Hole Ø (mm)	Ø A min-max (mm)	B Spanner (mm)	C (mm)	L min-max (mm)	Quantity
4901.M12	M12x1,5	12,2	3,5- 6,5	15	15	18-22	100
4901.M16	M16x1,5	16,2	6,5-10	19	15	22-27	100
4901.M20	M20x1,5	20,5	9 -13	25	15	24-30	50
4901.M25	M25x1,5	25,4	11 -17	30	15	30-41	50
4901.M32	M32x1,5	32,5	16 -21	36	15	33-44	25
4901.M40	M40x1,5	40,5	21 -28	46	18	36-45	15
4901.M50	M50x1,5	50,5	27 -35	55	18	43-52	10
4901.M63	M63x1,5	64,0	35 -42	66	18	45-55	5

Pg thread DIN 40 430

Type Light Grey	P	Fixing Hole Ø (mm)	Ø A min-max (mm)	B Spanner (mm)	C (mm)	L min-max (mm)	Quantity
4900.07	Pg 7	12,7	3,5- 6,5	15	8	18-22	100
4900.09	Pg 9	15,5	6,5- 8	19	8	22-26	100
4900.11	Pg11	18,8	8 -10	22	8	23-28	100
4900.13	Pg13,5	20,5	9 -12	24	9	24-29	100
4900.16	Pg16	22,6	10 -14	27	10	26-31	50
4900.21	Pg21	28,5	14 -18	33	12	30-35	50
4900.29	Pg29	37,2	18 -22	42	12	33-39	25
4900.36	Pg36	47,2	22 -32	53	14	42-49	10
4900.42	Pg42	54,2	28 -38	60	14	42-50	5
4900.48	Pg48	60,0	38 -45	66	15	45-55	5

extended thread

Type Light Grey	P	Fixing Hole Ø (mm)	Ø A min-max (mm)	B Spanner (mm)	C (mm)	L min-max (mm)	Quantity
4901.07	Pg 7	12,7	3,5- 6,5	15	15	18-22	100
4901.09	Pg 9	15,5	6,5- 8	19	15	22-26	100
4901.11	Pg11	18,8	8 -10	22	15	23-28	100
4901.13	Pg13,5	20,5	9 -12	24	15	24-29	100
4901.16	Pg16	22,6	10 -14	27	15	26-31	50
4901.21	Pg21	28,5	14 -18	33	15	30-35	50
4901.29	Pg29	37,2	18 -22	42	15	33-39	25
4901.36	Pg36	47,2	22 -32	53	18	42-49	10
4901.42	Pg42	54,2	28 -38	60	18	42-50	5
4901.48	Pg48	60,0	38 -45	66	18	45-55	5

CE 0051 **Ex** II 2 GD
Certificate No IMG 10 ATEX 028X



Material: POLYAMIDE PA6.6
self-extinguishing class V2 (UL 94)
Safety level: Ex e IIC/Ex tb IIIC
according to
EN 60079-0 : 2012
EN 60079-7 : 2007
EN 60079-31 : 2014
Areas of utilisation: 1 & 2, 21 & 22
Temperature range:
-20°C to +75°C (continuous)
Sealing ring: NEOPRENE®
Protection: IP 65
Colour: RAL 7035 light grey

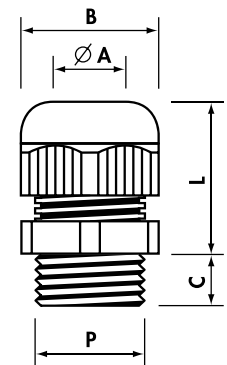

1700

1400

COMPRESSION CABLE GLANDS

Polyamide PA6



Pg thread DIN 40 430 - Dimensions DIN 46 320



Material: POLYAMIDE PA6
self-extinguishing class V0 (UL 94)
Temperature range:
-20°C to +90°C (continuous)
Sealing ring: PVC 50 sh A
Protection: IP 54
Colour: RAL 7035 light grey,
RAL 9005 black

Type Light Grey	P	Fixing Hole Ø (mm)	Ø A min-max (mm)	B1 Spanner Head (mm)	B2 Spanner Body (mm)	C (mm)	L min-max (mm)	Quantity Box/Bag
1709	Pg 7	12,7	5,5- 7	15	16	8	16-20	300/100
*1700	Pg 9	15,5	6,5- 8,5	17	20	8	19-22	200/100
*1701	Pg11	18,8	8 -10	19	22	8	21-25	100/100
*1702	Pg13,5	20,5	8 -11	21	24	9	22-26	100/100
1703	Pg16	22,6	11 -14	23	27	10	24-33	50/50
1704	Pg21	28,5	14,5-18	30	33	11	25-32	50/25
1705	Pg29	37,2	19 -26	40	42	11	27-32	20/10
1706	Pg36	47,2	30 -34	50	53	14	33-42	10/10
1707	Pg42	54,2	30 -38	55	60	13	37-48	5/5
1708	Pg48	60,0	38 -44	60	65	14,5	37-48	5/5

*Add to Ref: N for Black

BSP thread ISO 228/1

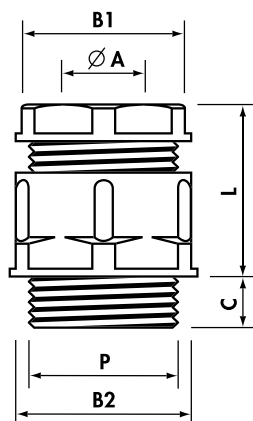

Type Light Grey	P	Fixing Hole Ø (mm)	Ø A min-max (mm)	B1 Spanner Head (mm)	B2 Spanner Body (mm)	C (mm)	L min-max (mm)	Quantity Box/Bag
1400	G1/4"	13,5	5,5- 7	15	16	8	16-20	300/100
*1401	G3/8"	17,0	6,5- 8,5	17	20	8	19-22	200/100
*1401B	G3/8"	17,0	8 -10	19	22	8	18-24	100/100
*1402	G1/2"	21,5	8 -11	21	24	9	22-26	100/100
1403	G5/8"	23,5	11 -14	23	27	10	24-33	50/50
1404	G3/4"	27,0	14,5-18	30	33	11	25-32	50/25
1405	G1"	34,0	17 -22	34	38	11,5	27-35	20/10
1407	G1*1/2	48,0	30 -34	50	53	14	33-42	10/10
1408	G2"	60,0	38 -44	60	65	14,5	37-48	5/5

*Add to Ref: N for Black

Metric thread M 1.5 pitch CEI EN 60423

Type Light Grey	P	Fixing Hole Ø (mm)	Ø A min-max (mm)	B1 Spanner Head (mm)	B2 Spanner Body (mm)	C (mm)	L min-max (mm)	Quantity
1730M20	M20x1,5	20,5	8-11	21	24	9	22-26	100

Add to Ref: N for Black

COMPRESSION CABLE GLANDS

Polyamide PA6

special Internal blanking disc: PVC 50 sh

Pg thread DIN 40 430 - Dimensions DIN 46 320

Type Light Grey	P	Fixing Hole Ø (mm)	Ø A min-max (mm)	B1 Spanner Head (mm)	B2 Spanner Body (mm)	C (mm)	L min-max (mm)	Quantity Box/Bag
*1700T	Pg 9	15,5	6,5- 8,5	17	20	8	19-22	200/100
*1701T	Pg11	18,8	8 -10	19	22	8	21-25	100/100
*1702T	Pg13,5	20,5	8 -11	21	24	9	22-26	100/100

*Add to Ref: N for Black

reduced cable entry

Sealing ring: CHLOROPRENE, concentric, multi-sector

Pg thread DIN 40 430 - Dimensions DIN 46 320

Type Light Grey	P	Fixing Hole Ø (mm)	Ø A min-max (mm)	B1 Spanner Head (mm)	B2 Spanner Body (mm)	C (mm)	L min-max (mm)	Quantity
1702CONC	Pg13,5	20,5	5,5-13	21	24	9	22-26	100

Add to Ref: N for Black

1700T



Material: POLYAMIDE PA6
self-extinguishing class V0 (UL 94)
Temperature range:
-20°C to +90°C (continuous)
Protection: IP 54
Colour: RAL 7035 light grey,
RAL 9005 black

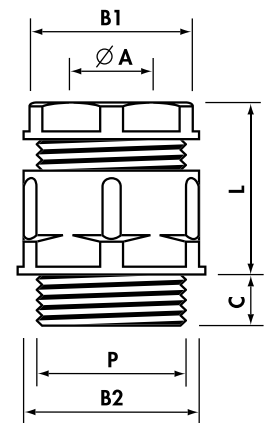

POLYSTYRENE CABLE GLANDS

Polystyrene PS

Sealing ring: PVC 50 sh A - Protection: IP 54

Pg thread DIN 40 430 - Dimensions DIN 46 320

Type Light Grey	P	Fixing Hole Ø (mm)	Ø A min-max (mm)	B1 Spanner Head (mm)	B2 Spanner Body (mm)	C (mm)	L min-max (mm)	Quantity Box/Bag
1700P	Pg9	15,5	7- 8,5	17	20	8	19-22	200/100
*1701P	Pg11	18,8	8 -10	19	22	8	21-25	100/100
*1702P	Pg13,5	20,5	8 -11	21	24	9	22-26	100/100
1703P	Pg16	22,6	11 -14	23	27	10	24-33	50/50
1704P	Pg21	28,5	14,5-18	30	33	11	25-32	50/25

*Add to Ref: N for Black

1700P



Material: POLYSTYRENE PS
Temperature range:
-20°C to +60°C (continuous)
Colour: RAL 7035 light grey,
RAL 9005 black



Material: NICKEL PLATED BRASS
(CuZn 40 Pb 3)
Sealing-ring: NEOPRENE®
Cable grip insert: POLYAMIDE PA6.6
O-Ring: NITRILE 70 sh A (factory fitted)
Protection: IP 68
Temperature range:
-25°C to +100°C (continuous)

standard

Metric thread M 1.5 pitch CEI EN 60423 CEI EN 62444

Type Nickel Plated Brass	P	Fixing Hole Ø (mm)	Ø A min-max (mm)	B Spanner (mm)	E (mm)	C (mm)	L min-max (mm)	Quantity
2900.M12N	M12x1,5	12,2	3 - 7	16	18	6,5	16-20	100
2900.M16N	M16x1,5	16,2	4,5-10	20	23	7,0	20-25	100
2900.M20N	M20x1,5	20,5	7 -13	24	27	8,0	20-27	50
2900.M25N	M25x1,5	25,4	10 -17	29	32	8,0	24-30	50
2900.M32N	M32x1,5	32,5	11 -21	36	40	9,0	27-34	25
2900.M40N	M40x1,5	40,5	19 -28	45	50	9,0	34-42	10
2900.M50N	M50x1,5	50,5	26 -35	54	60	10,0	35-43	8
2900.M63N	M63x1,5	64,0	34 -45	67	74	15,0	40-52	5

reduced cable entry

Metric thread M 1.5 pitch CEI EN 60423 CEI EN 62444

Type Nickel Plated Brass	P	Fixing Hole Ø (mm)	Ø A min-max (mm)	B Spanner (mm)	E (mm)	C (mm)	L min-max (mm)	Quantity
2910.M12N	M12x1,5	12,2	1 - 5	16	18	6,5	16-20	100
2910.M16N	M16x1,5	16,2	2,5- 7	20	23	7,0	20-25	100
2910.M20N	M20x1,5	20,5	5 -10	24	27	8,0	20-27	50
2910.M25N	M25x1,5	25,4	6 -13	29	32	8,0	24-30	50
2910.M32N	M32x1,5	32,5	7 -14	36	40	9,0	27-34	25
2910.M40N	M40x1,5	40,5	13 -23	45	50	9,0	34-42	10
2910.M50N	M50x1,5	50,5	20 -29	54	60	10,0	35-43	8
2910.M63N	M63x1,5	64,0	27 -39	67	74	15,0	40-52	5

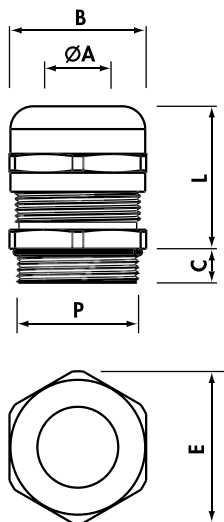

MAXIBRASS CABLE GLANDS

2900

Nickel Plated Brass

MAXIbrass®



extended thread

Metric thread M 1.5 pitch CEI EN 60423 CEI EN 62444

Type Nickel Plated Brass	P	Fixing Hole Ø (mm)	Ø A min-max (mm)	B Spanner (mm)	E (mm)	C (mm)	L min-max (mm)	Quantity
2901.M12N	M12x1,5	12,2	3 - 7	16	18	12	16-20	100
2901.M16N	M16x1,5	16,2	4,5-10	20	23	12	20-25	100
2901.M20N	M20x1,5	20,5	7 -13	24	27	12	20-27	50
2901.M25N	M25x1,5	25,4	10 -17	29	32	12	24-30	50
2901.M32N	M32x1,5	32,5	11 -21	36	40	15	27-34	25
2901.M40N	M40x1,5	40,5	19 -28	45	50	15	34-42	10
2901.M50N	M50x1,5	50,5	26 -35	54	60	15	35-43	8



Material: NICKEL PLATED BRASS (CuZn 40 Pb 3)
 Sealing-ring: NEOPRENE®
 Cable grip insert: POLYAMIDE PA6.6
 O-Ring: NITRILE 70 sh A (factory fitted)
 Protection: IP 68
 Temperature range: -25°C to +100°C (continuous)

extended thread and reduced cable entry

Metric thread M 1.5 pitch CEI EN 60423 CEI EN 62444

Type Nickel Plated Brass	P	Fixing Hole Ø (mm)	Ø A min-max (mm)	B Spanner (mm)	E (mm)	C (mm)	L min-max (mm)	Quantity
2911.M12N	M12x1,5	12,2	1 - 5	16	18	12	16-20	100
2911.M16N	M16x1,5	16,2	2,5- 7	20	23	12	20-25	100
2911.M20N	M20x1,5	20,5	5 -10	24	27	12	20-27	50
2911.M25N	M25x1,5	25,4	6 -13	29	32	12	24-30	50
2911.M32N	M32x1,5	32,5	7 -14	36	40	15	27-34	25
2911.M40N	M40x1,5	40,5	13 -23	45	50	15	34-42	10
2911.M50N	M50x1,5	50,5	20 -29	54	60	15	35-43	8

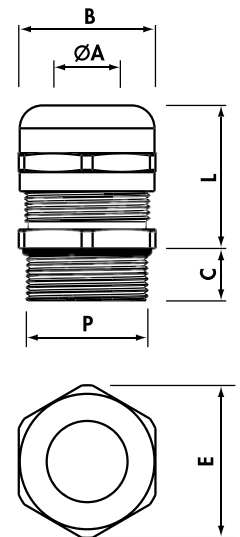



Material: NICKEL PLATED BRASS
(CuZn 40 Pb 3)
Sealing-ring: NEOPRENE®
Cable grip insert: POLYAMIDE PA6.6
O-Ring: NITRILE 70 sh A (factory fitted)
Protection: IP 68
Temperature range:
-25°C to +100°C (continuous)

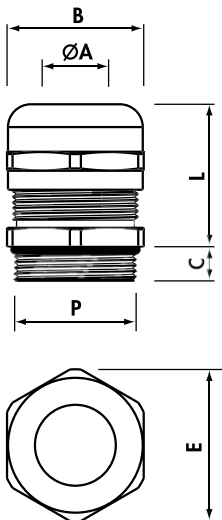

standard

Pg thread DIN 40 430

Type Nickel Plated Brass	P	Fixing Hole Ø (mm)	Ø A min-max (mm)	B Spanner (mm)	E (mm)	C (mm)	L min-max (mm)	Quantity
2900.07N	Pg 7	12,7	3 - 7	16	18	5,0	16-20	100
2900.09N	Pg 9	15,5	4 - 8	17	19	6,0	17-23	100
2900.11N	Pg11	18,8	4,5-10	20	23	6,0	20-25	100
2900.13N	Pg13,5	20,5	5 -12	22	25	6,5	20-26	50
2900.16N	Pg16	22,6	7 -13	24	27	6,5	20-27	50
2900.21N	Pg21	28,5	10 -17	30	33	7,0	24-30	50
2900.29N	Pg29	37,2	17 -25	40	45	8,0	30-37	25
2900.36N	Pg36	47,2	20 -32	50	55	8,0	38-48	10
2900.42N	Pg42	54,2	28 -38	57	63	10,0	39-48	5
2900.48N	Pg48	60,0	34 -45	67	74	15,0	40-52	5

reduced cable entry

Pg thread DIN 40 430

Type Nickel Plated Brass	P	Fixing Hole Ø (mm)	Ø A min-max (mm)	B Spanner (mm)	E (mm)	C (mm)	L min-max (mm)	Quantity
2910.07N	Pg 7	12,7	1 - 5	16	18	5,0	16-20	100
2910.09N	Pg 9	15,5	2 - 6	17	19	6,0	17-23	100
2910.11N	Pg11	18,8	2,5- 7	20	23	6,0	20-25	100
2910.13N	Pg13,5	20,5	4 -10	22	25	6,5	20-26	50
2910.16N	Pg16	22,6	5 -10	24	27	6,5	20-27	50
2910.21N	Pg21	28,5	6 -13	30	33	7,0	24-30	50
2910.29N	Pg29	37,2	11 -20	40	45	8,0	30-37	25
2910.36N	Pg36	47,2	18 -26	50	55	8,0	38-48	10
2910.42N	Pg42	54,2	24 -31	57	63	10,0	39-48	5
2910.48N	Pg48	60,0	27 -39	67	74	15,0	40-52	5

extended thread

Pg thread DIN 40 430

Type Nickel Plated Brass	P	Fixing Hole Ø (mm)	Ø A min-max (mm)	B Spanner (mm)	E (mm)	C (mm)	L min-max (mm)	Quantity
2901.07N	Pg 7	12,7	3 - 7	16	18	12	16-20	100
2901.09N	Pg 9	15,5	4 - 8	17	19	12	17-23	100
2901.11N	Pg11	18,8	4,5-10	20	23	12	20-25	100
2901.13N	Pg13,5	20,5	5 -12	22	25	12	20-26	50
2901.16N	Pg16	22,6	7 -13	24	27	12	20-27	50
2901.21N	Pg21	28,5	10 -17	30	33	12	24-30	50
2901.29N	Pg29	37,2	17 -25	40	45	15	30-37	25
2901.36N	Pg36	47,2	20 -32	50	55	15	38-48	10
2901.42N	Pg42	54,2	28 -38	57	63	15	39-48	5

MAXIBRASS CABLE GLANDS

Nickel Plated Brass

MAXIbrass®

extended thread and reduced cable entry

Pg thread DIN 40 430

Type Nickel Plated Brass	P	Fixing Hole Ø (mm)	Ø A min-max (mm)	B Spanner (mm)	E (mm)	C (mm)	L min-max (mm)	Quantity
2911.07N	Pg 7	12,7	1 - 5	16	18	12	16-20	100
2911.09N	Pg 9	15,5	2 - 6	17	19	12	17-23	100
2911.11N	Pg11	18,8	2,5- 7	20	23	12	20-25	100
2911.13N	Pg13,5	20,5	4 -10	22	25	12	20-26	50
2911.16N	Pg16	22,6	5 -10	24	27	12	20-27	100
2911.21N	Pg21	28,5	6 -13	30	33	12	24-30	50
2911.29N	Pg29	37,2	11 -20	40	45	15	30-37	25
2911.36N	Pg36	47,2	18 -26	50	55	15	38-48	10
2911.42N	Pg42	54,2	24 -31	57	63	15	39-48	5



MAXIBRASS CABLE GLANDS

Nickel Plated Brass

standard, factory fitted with Polyethylene foam discs

Metric thread M 1.5 pitch CEI EN 60423 CEI EN 62444

Type Nickel Plated Brass	P	Fixing Hole Ø (mm)	Ø A min-max (mm)	B Spanner (mm)	E (mm)	C (mm)	L min-max (mm)	Quantity
2900DP.M12N	M12x1,5	12,2	3 - 7	16	18	6,5	16-20	100
2900DP.M16N	M16x1,5	16,2	4,5-10	20	23	7,0	20-25	100
2900DP.M20N	M20x1,5	20,5	7 -13	24	27	8,0	20-27	50
2900DP.M25N	M25x1,5	25,4	10 -17	29	32	8,0	24-30	50
2900DP.M32N	M32x1,5	32,5	11 -21	36	40	9,0	27-34	25
2900DP.M40N	M40x1,5	40,5	19 -28	45	50	9,0	34-42	10
2900DP.M50N	M50x1,5	50,5	26 -35	54	60	10,0	35-43	8
2900DP.M63N	M63x1,5	64,0	34 -45	67	74	15,0	40-52	5

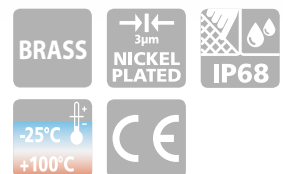

Pg thread DIN 40 430

Type Nickel Plated Brass	P	Fixing Hole Ø (mm)	Ø A min-max (mm)	B Spanner (mm)	E (mm)	C (mm)	L min-max (mm)	Quantity
2900DP.07N	Pg 7	12,7	3 - 7	16	18	5,0	16-20	100
2900DP.09N	Pg 9	15,5	4 - 8	17	19	6,0	17-23	100
2900DP.11N	Pg11	18,8	4,5-10	20	23	6,0	20-25	100
2900DP.13N	Pg13,5	20,5	5 -12	22	25	6,5	20-26	50
2900DP.16N	Pg16	22,6	7 -13	24	27	6,5	20-27	50
2900DP.21N	Pg21	28,5	10 -17	30	33	7,0	24-30	50
2900DP.29N	Pg29	37,2	17 -25	40	45	8,0	30-37	25
2900DP.36N	Pg36	47,2	20 -32	50	55	8,0	38-48	10
2900DP.42N	Pg42	54,2	28 -38	57	63	10,0	39-48	5
2900DP.48N	Pg48	60,0	34 -45	67	74	15,0	40-52	5

Material: NICKEL PLATED BRASS (CuZn 40 Pb 3)
 Sealing-ring: NEOPRENE®
 Cable grip insert: POLYAMIDE PA6.6
 O-Ring: NITRILE 70 sh A (factory fitted)
 Protection: IP 68
 Discs: 2 mm thick Polyethylene foam
 Temperature range:
 -25°C to +100°C (continuous)

5900

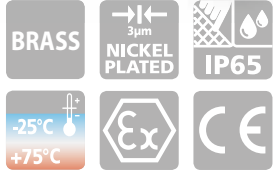

Material: NICKEL PLATED BRASS
 Sealing-ring: NEOPRENE®
 Cable grip insert: POLYAMIDE PA6.6
 O-Ring: NITRILE 70 sh A (factory fitted)
 Temperature range:
 -25°C to +75°C (continuous)
 Protection: IP 65

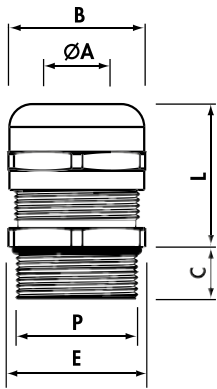

20M3

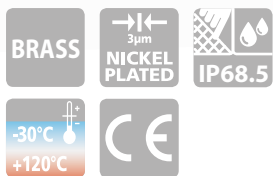

Material: NICKEL PLATED BRASS
 (CuZn 40 Pb 3)
 Sealing-ring: Chloroprene (CR)
 Cable grip insert: PA6.6
 O-Ring: (NBR) (factory fitted)
 Protection: IP 68,5
 Temperature range:
 -30°C to +120°C (continuous)

MAXIBRASS ATEX CABLE GLANDS

Nickel Plated Brass



Certificate No IMG 10 ATEX 028X

Safety level: Ex e IIC/Ex tb IIIC
 according to: EN 60079-0 : 2012
 EN 60079-7 : 2007
 EN 60079-31 : 2014
 Areas of utilisation: 1 & 2, 21 & 22

MAXIbrass®

Metric thread M 1.5 pitch CEI EN 60423 CEI EN 62444

Type Nickel Plated Brass	P	Fixing Hole Ø (mm)	Ø A min-max (mm)	B Spanner (mm)	E (mm)	C (mm)	L min-max (mm)	Quantity
5900.M12N	M12x1,5	12,2	3 - 6,5	16	18	6,5	16-20	100
5900.M16N	M16x1,5	16,2	6,5 - 10	20	23	7,0	20-25	100
5900.M20N	M20x1,5	20,5	10 - 13	24	27	8,0	20-27	50
5900.M25N	M25x1,5	25,4	11 - 17	29	32	8,0	24-30	50
5900.M32N	M32x1,5	32,5	14 - 21	36	40	9,0	27-34	25
5900.M40N	M40x1,5	40,5	21 - 27	45	50	9,0	34-42	10
5900.M50N	M50x1,5	50,5	26 - 35	54	60	10,0	35-43	8
5900.M63N	M63x1,5	64,0	35 - 42	67	74	15,0	40-52	5

extended thread

Type Nickel Plated Brass	P	Fixing Hole Ø (mm)	Ø A min-max (mm)	B Spanner (mm)	E (mm)	C (mm)	L min-max (mm)	Quantity
5901.M12N	M12x1,5	12,2	3 - 6,5	16	18	12	16-20	100
5901.M16N	M16x1,5	16,2	6,5 - 10	20	23	12	20-25	100
5901.M20N	M20x1,5	20,5	10 - 13	24	27	12	20-27	50
5901.M25N	M25x1,5	25,4	11 - 17	29	32	12	24-30	50
5901.M32N	M32x1,5	32,5	14 - 21	36	40	12	27-34	25
5901.M40N	M40x1,5	40,5	21 - 27	45	50	12	34-42	10
5901.M50N	M50x1,5	50,5	26 - 35	54	60	12	35-43	8

EMC CABLE GLANDS

Nickel Plated Brass

Metric thread M 1.5 pitch CEI EN 60423 CEI EN 62444

Type Nickel Plated Brass	P	Fixing Hole Ø (mm)	Ø A min-max (mm)	B Spanner (mm)	C (mm)	L max (mm)	Quantity Box/Bag
20M3M1261N	M12x1,5	12,2	3 - 6,5	14	5,0	22,0	300/100
20M3M1661N	M16x1,5	16,2	5,5 - 10	17	5,5	24,5	200/100
20M3M2061N	M20x1,5	20,5	8 - 13	22	6,0	27,0	100/50
20M3M2561N	M25x1,5	25,4	11 - 18	30	7,0	31,0	50/25
20M3M3261N	M32x1,5	32,5	15 - 21	34	8,0	33,0	30/10
20M3M4061N	M40x1,5	40,5	19 - 27	44	8,0	40,0	20/10
20M3M5061N	M50x1,5	50,5	26 - 35	55	9,0	48,0	10/5
20M3M6361N	M63x1,5	64,0	39 - 48	66	10,0	50,0	5/5

EMC Cable glands and locknuts are designed to work together in electrical or electronic applications where a metallic cable shielding must be equipotential with a metallic enclosure, in accordance with the EMC directive.

Offering IP68 ingress protection at 5 bar pressure, EMC Cable glands will maintain shielding from electromagnetic disturbance in underground applications.

EMC locknuts have serrated teeth to maintain electrical contact through paint or surface coatings, a feature which also enhances vibration resistance.

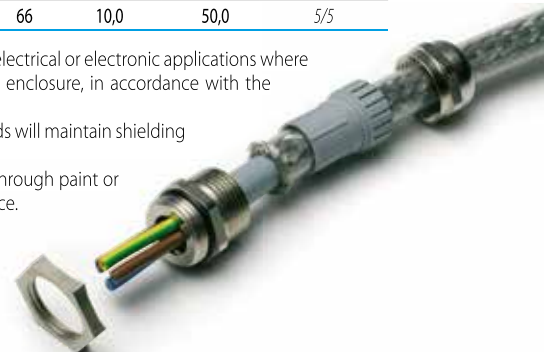

COMPRESSION CABLE GLANDS

Nickel Plated Brass

2003
2002
2001

Sealing ring: RUBBER 55sh A

Metric thread M 1.5 pitch CEI EN 60423 CEI EN 62444

Type Nickel Plated Brass	P	Fixing Hole Ø (mm)	Ø A min-max (mm)	B1 Spanner Head (mm)	B2 Spanner Body (mm)	C (mm)	L min-max (mm)	Quantity Box/Bag
2003M1221N	M12x1,5	12,2	4 - 6	13	14	5	13-16	500/100
2003M1621N	M16x1,5	16,2	8 -10	15	18	5	14-17	200/100
2003M2021N	M20x1,5	20,5	10 -12	20	22	6	16-19	150/50
2003M2521N	M25x1,5	25,4	17 -19	28	30	7	19-23	50/50
2003M3221N	M32x1,5	32,5	26 -28	37	39	8	21-25	100/50
2003M4021N	M40x1,5	40,5	33 -35	47	50	8	24-30	20/20
2003M5021N	M50x1,5	50,5	39 -41	54	57	9	28-34	10/5
2003M6321N	M63x1,5	64,0	43 -45	60	66/68	10	30-36	10/5

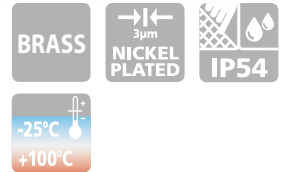

Sealing ring: RUBBER 55sh A

Pg thread DIN 40 430 - Dimensions DIN 46 320

Type Nickel Plated Brass	P	Fixing Hole Ø (mm)	Ø A min-max (mm)	B1 Spanner Head (mm)	B2 Spanner Body (mm)	C (mm)	L min-max (mm)	Quantity Box/Bag
200200721N	Pg 7	12,7	5 - 7	13	14	5	13-16	400/100
200200921N	Pg 9	15,5	8 -10	15	17	6	14-17	300/100
200201121N	Pg11	18,8	8 -10	18	20	6	14-18	200/50
200201321N	Pg13,5	20,5	10 -12	20	22	6,5	16-19	100/50
200201621N	Pg16	22,6	12 -14	22	24	6,5	17-20	50/50
200202121N	Pg21	28,5	17 -19	28	30	7	19-23	50/50
200202921N	Pg29	37,2	26 -28	37	40	8	21-25	15/15
200203621N*	Pg36	47,2	33 -35	47	50	9	24-30	10/10
200204221N	Pg42	54,2	39 -41	54	57	10	28-34	10/10
200204821N*	Pg48	60,0	43 -45	60	64	10	36-45	10/10

* Double sealing ring

Material: NICKEL PLATED BRASS
(CuZn 40 Pb 3)
Protection: IP 54

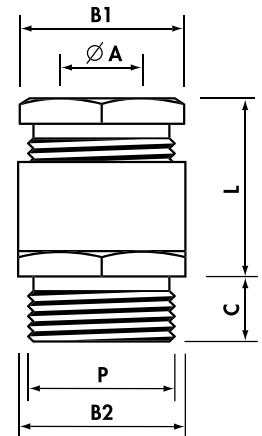

Sealing ring: PVC 50 sh A

BSP thread ISO 228/1

Type Nickel Plated Brass	P	Fixing Hole Ø (mm)	Ø A min-max (mm)	B1 Spanner Head (mm)	B2 Spanner Body (mm)	C (mm)	L min-max (mm)	Quantity Box/Bag
200101441N	G1/4"	13,5	5,5 - 7	13	15	6,5	14-17	400/100
207101441N	G1/4"	13,5	5,5 - 7	13	Ø 15	6,5	14-17	400/100
200103841N	G3/8"	17,0	6,5 - 8,5	17	19	7,5	15-19	200/100
200101241N	G1/2"	21,5	8 -11	21	23	8	17-23	100/100
200105841N	G5/8"	23,5	11 -14	23	25	8,5	20-24	100/50
200103441N	G3/4"	27,0	14,5-17,5	27	29	9	20-26	50/50
200110041N	G1"	34,0	18 -22	34	36	10	23-28	25/25
200111841N	G1"1/8	38,0	21 -26	38	40	10,5	23-28	25/25
200111441N	G1"1/4	42,0	28 -32	42	45	11,5	25-31	20/20
200111241N	G1"1/2	48,0	32 -36	48	50	11,5	28-35	10/10
200120041N	G2"	60,0	38 -42	60	64	13,5	31-37	10/10
• 200121221N*	G2"1/2	76,0	44 -57	80	80	20	32-37	5/5
• 200130021N	G3"	89,0	67 -69	95	95	20	42-52	5/5

• Sealing ring: Chloroprene

* Concentric sealing ring

7900 7900A

MAXIINOX CABLE GLANDS

Stainless Steel AISI 303 (X8 CrNiS 18-9)

Stainless Steel AISI 316L (X2 CrNiMo 17-12-2)

MAXIinox



Material:
STAINLESS STEEL AISI 303/316L
Sealing-ring: NEOPRENE®
Cable grip insert: POLYAMIDE PA6.6
O-Ring: NITRILE 70 sh A
(factory fitted)
Protection: IP 68
Temperature range:
-25°C to +100°C (continuous)

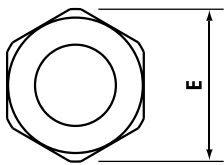
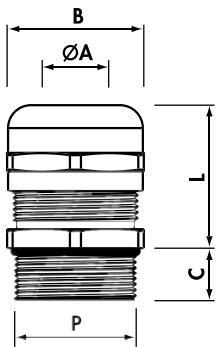

Stainless Steel AISI 303

Metric thread M 1.5 pitch CEI EN 60423 CEI EN 62444

Stainless Steel AISI 303	P	Fixing Hole Ø (mm)	Ø A min-max (mm)	B Spanner (mm)	E (mm)	C (mm)	L min-max (mm)	Quantity Box/Bag
7900.M12	M12x1,5	12,2	3 - 7	16	18	6,5	16-20	90/30
7900.M16	M16x1,5	16,2	4,5-10	20	23	7,0	20-25	120/30
7900.M20	M20x1,5	20,5	7 -13	24	27	8,0	20-27	75/25
7900.M25	M25x1,5	25,4	10 -17	29	32	8,0	24-30	40/20
7900.M32	M32x1,5	32,5	11 -21	36	40	9,0	27-34	15
7900.M40	M40x1,5	40,5	19 -28	45	50	9,0	34-42	15
7900.M50	M50x1,5	50,5	26 -35	54	60	10,0	35-43	10
7900.M63	M63x1,5	64,0	34 -45	67	74	15,0	40-52	5

Stainless Steel AISI 316L

Metric thread M 1.5 pitch CEI EN 60423 CEI EN 62444

Stainless Steel AISI 316L	P	Fixing Hole Ø (mm)	Ø A min-max (mm)	B Spanner (mm)	E (mm)	C (mm)	L min-max (mm)	Quantity Box/Bag
7900A.M12	M12x1,5	12,2	3 - 7	16	18	6,5	16-20	60/20
7900A.M16	M16x1,5	16,2	4,5-10	20	23	7,0	20-25	80/20
7900A.M20	M20x1,5	20,5	7 -13	24	27	8,0	20-27	60/20
7900A.M25	M25x1,5	25,4	10 -17	29	32	8,0	24-30	30/15
7900A.M32	M32x1,5	32,5	11 -21	36	40	9,0	27-34	12
7900A.M40	M40x1,5	40,5	19 -28	45	50	9,0	34-42	10
7900A.M50	M50x1,5	50,5	26 -35	54	60	10,0	35-43	7
7900A.M63	M63x1,5	64,0	34 -45	67	74	15,0	40-52	5

MAXIINOX CABLE GLANDS

Stainless Steel AISI 303 (X8 CrNiS 18-9)

Stainless Steel AISI 316L (X2 CrNiMo 17-12-2)

MAXIinox

7900 7900A



Stainless Steel AISI 303

Pg thread DIN 40 430

Stainless Steel AISI 303	P	Fixing Hole Ø (mm)	Ø A min-max (mm)	B Spanner (mm)	E (mm)	C (mm)	L min-max (mm)	Quantity Box/Bag
7900.07	Pg 7	12,7	3 - 7	16	18	5,0	16-20	90/30
7900.09	Pg 9	15,5	4 - 8	17	19	6,0	17-23	90/30
7900.11	Pg11	18,8	4,5-10	20	23	6,0	20-25	60/30
7900.13	Pg13,5	20,5	5 - 12	22	25	6,5	20-26	90/30
7900.16	Pg16	22,6	7 - 13	24	27	6,5	20-27	60/30
7900.21	Pg21	28,5	10 - 17	30	33	7,0	24-30	40/20
7900.29	Pg29	37,2	17 - 25	40	45	8,0	30-37	30/15
7900.36	Pg36	47,2	20 - 32	50	55	8,0	38-48	10
7900.42	Pg42	54,2	28 - 38	57	63	10,0	36-46	5
7900.48	Pg48	60,0	34 - 45	67	74	15,0	40-52	5

Material:
STAINLESS STEEL AISI 303/316L
Sealing-ring: NEOPRENE®
Cable grip insert: POLYAMIDE PA6.6
O-Ring: NITRILE 70 sh A
(factory fitted)
Protection: IP 68
Temperature range:
-25°C to +100°C (continuous)

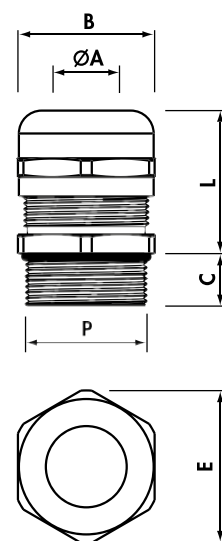

Stainless Steel AISI 316L

Pg thread DIN 40 430

Stainless Steel AISI 316L	P	Fixing Hole Ø (mm)	Ø A min-max (mm)	B Spanner (mm)	E (mm)	C (mm)	L min-max (mm)	Quantity Box/Bag
7900A.07	Pg 7	12,7	3 - 7	16	18	5,0	16-20	60/20
7900A.09	Pg 9	15,5	4 - 8	17	19	6,0	17-23	60/20
7900A.11	Pg11	18,8	4,5-10	20	23	6,0	20-25	100/20
7900A.13	Pg13,5	20,5	5 - 12	22	25	6,5	20-26	100/20
7900A.16	Pg16	22,6	7 - 13	24	27	6,5	20-27	40/20
7900A.21	Pg21	28,5	10 - 17	30	33	7,0	24-30	60/15
7900A.29	Pg29	37,2	17 - 25	40	45	8,0	30-37	20/10
7900A.36	Pg36	47,2	20 - 32	50	55	8,0	38-48	7
7900A.42	Pg42	54,2	28 - 38	57	63	10,0	36-46	5
7900A.48	Pg48	60,0	34 - 45	67	74	15,0	40-52	5

1143
1142
1141

LOCKNUTS WITH COLLAR

Polyamide PA6.6



PA 6.6



Material: POLYAMIDE PA6.6
self-extinguishing class V2 (UL 94)
Temperature range:
-20°C to +90°C (continuous)
Colour: RAL 7035 light grey,
RAL 9005 black,
RAL 7001 dark grey

Metric thread M 1.5 pitch CEI EN 60423

Type Light Grey	P	Ø A (mm)	B Spanner (mm)	H (mm)	Quantity Box/Bag
1143M12	M12x1,5	18,5	17	5	1.000/100
1143M16	M16x1,5	24,0	22	5	600/100
1143M20	M20x1,5	29,0	27	6	400/100
1143M25	M25x1,5	35,5	32	6	100
1143M32	M32x1,5	45,0	41	7	50
1143M40	M40x1,5	55,0	50	7	30
1143M50	M50x1,5	65,0	60	8	30
1143M63	M63x1,5	82,0	75	8	15

Add to Ref: N for Black, G for Dark Grey

Pg thread DIN 40 430 - Dimensions DIN 46 320

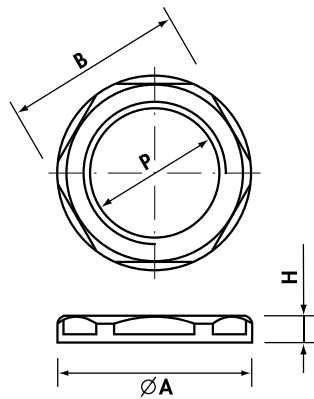

Type Light Grey	P	Ø A (mm)	B Spanner (mm)	H (mm)	Quantity Box/Bag
1142007	Pg 7	21	19	5	100
1142009	Pg 9	24	22	5	700/100
1142011	Pg11	26	24	5	500/100
1142013	Pg13,5	29	27	6	400/100
1142016	Pg16	33	30	6	100
1142021	Pg21	39	36	7	200/50
1142029	Pg29	50	46	7	50
1142036	Pg36	66	60	8	30
1142042	Pg42	73	65	8	25
1142048	Pg48	78	70	8	20

Add to Ref: N for Black, G for Dark Grey

BSP thread ISO 228/1

Type Light Grey	P	Ø A (mm)	B Spanner (mm)	H (mm)	Quantity Box/Bag
1141012	G1/2"	29	27	6	400/100
1141112	G1"1/2	66	60	8	30
1141200	G2"	78	70	8	20

Add to Ref: N for Black

LOCKNUTS WITHOUT COLLAR

Polyamide PA6.6

1112
1710
1410



Metric thread M 1.5 pitch CEI EN 60423

Type Light Grey	P	B Spanner (mm)	H (mm)	Quantity Box/Bag
1112	M12x1,5	17	5	1.000/100
1116	M16x1,5	22	5	700/100
1120	M20x1,5	27	6	400/100
1125	M25x1,5	32	6	100
1132	M32x1,5	41	7	50
1140	M40x1,5	50	7	30
1150	M50x1,5	60	8	30
1163	M63x1,5	75	8	15

Add to Ref: N for Black



Material: POLYAMIDE PA6.6
self-extinguishing class V2 (UL 94)
Temperature range:
-20°C to +90°C (continuous)
Colour: RAL 7035 light grey,
RAL 9005 black

Pg thread DIN 40 430 - Dimensions DIN 46 320

Type Light Grey	P	B Spanner (mm)	H (mm)	Quantity Box/Bag
1719E17*	Pg 7	17	5	1.000/100
1719	Pg 7	19	5	100
1710	Pg 9	22	5	700/100
1711	Pg11	24	5	500/100
1712	Pg13,5	27	6	400/100
1713	Pg16	30	6	100
Δ1714E34*	Pg21	34	7	200/100
1714	Pg21	36	7	200/100
1715	Pg29	46	7,5	100/50

Add to Ref: N for Black

Δ Light Grey only

* Not DIN 46 320

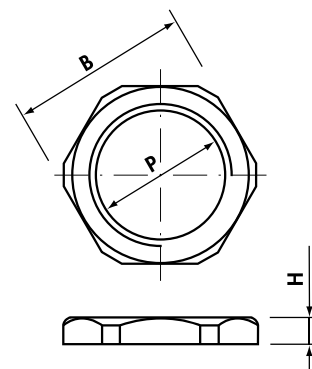

BSP thread ISO 228/1

Type Light Grey	P	B Spanner (mm)	H (mm)	Quantity Box/Bag
1410	G1/4"	19	5	800/100
1411	G3/8"	23	6	600/100
1412	G1/2"	27	6	400/100
1414	G3/4"	34	7	200/100
1415	G1"	40	7	50

Add to Ref: N for Black

2033
2032
2031



LOCKNUTS

Nickel Plated Brass

Metric thread M 1.5 pitch CEI EN 60423

Type Nickel Plated Brass	P	B Spanner (mm)	H (mm)	Quantity Box/Bag
2033M12N	M12x1,5	16	2,8	2.000/100
2033M16N	M16x1,5	19	2,8	1.000/100
2033M20N	M20x1,5	24	3,0	600/100
2033M25N	M25x1,5	30	4,0	300/50
2033M32N	M32x1,5	36	4,0	250/25
2033M40N	M40x1,5	45	5,0	100/10
2033M50N	M50x1,5	60	5,0	100/10
2033M63N	M63x1,5	70	5,5	50/5

Pg thread DIN 40 430 - Dimensions DIN 46 320

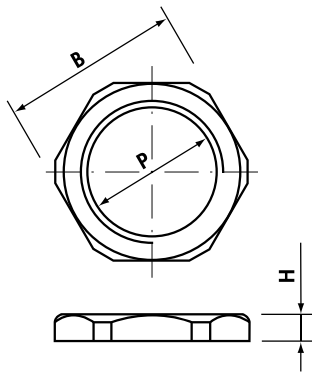

Type Nickel Plated Brass	P	B Spanner (mm)	H (mm)	Quantity Box/Bag
2032007N	Pg 7	16*	2,8	1.500/100
2032009N	Pg 9	18	2,8	1.500/100
2032011N	Pg11	21	3,0	1.000/100
2032013N	Pg13,5	23	3,0	1.000/100
2032016N	Pg16	26	3,0	600/100
2032021N	Pg21	32	3,5	500/100
2032029N	Pg29	41	4,0	200/50
2032036N	Pg36	51	5,0	100/10
2032042N	Pg42	60	5,0	50/10
2032048N	Pg48	64	5,5	50/10

*Different dimension to DIN 46320

BSP thread ISO 228/1

Type Nickel Plated Brass	P	B Spanner (mm)	H (mm)	Quantity Box/Bag
2031014N	G1/4"	16	3,0	2.400/100
2031038N	G3/8"	19	3,0	1.000/100
2031012N	G1/2"	24	3,5	1.000/100
2031058N	G5/8"	26	4,0	500/50
2031034N	G3/4"	30	4,0	500/50
2031100N	G1"	37	4,0	250/25
2031118N	G1"1/8	41	4,5	100/25
2031114N	G1"1/4	45	4,5	200/20
2031112N	G1"1/2	52	5,5	100/20
2031200N	G2"	64	7,0	50/10
2031212N	G2"1/2	80	7,0	20/5
2031300N	G3"	95	8,0	20/5

EMC LOCKNUTS

Nickel Plated Brass

20N3



With serrated teeth to maintain electrical contact

Metric thread M 1.5 pitch CEI EN 60423

Type Nickel Plated Brass	P	B Spanner (mm)	H (mm)	Quantity Box/Bag
20N3M12N	M12x1,5	15	3,5	1000/100
20N3M16N	M16x1,5	19	3,5	1000/100
20N3M20N	M20x1,5	24	3,5	500/100
20N3M25N	M25x1,5	30	4,0	400/100
20N3M32N	M32x1,5	36	4,0	200/100
20N3M40N	M40x1,5	46	4,7	100/50
20N3M50N	M50x1,5	60	5,7	50/50
20N3M63N	M63x1,5	70	6,7	50/25

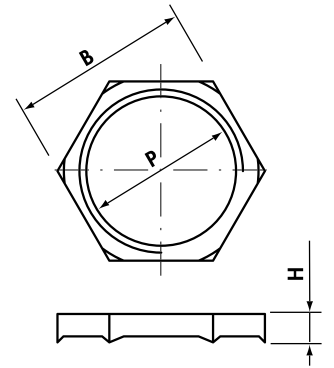

MAXIINOX LOCKNUTS

Stainless Steel AISI 303 (X8 CrNiS 18-9)

Stainless Steel AISI 316L (X2 CrNiMo 17-12-2)

7032 7033



Metric thread M 1.5 pitch CEI EN 60423

Stainless Steel AISI 303	Stainless Steel AISI 316L	P	B Spanner (mm)	H (mm)	AISI 303 Quantity Box/Bag	AISI 316L Quantity Box/Bag
7033M12	7033AM12	M12x1,5	16	2,8	450/30	300/20
7033M16	7033AM16	M16x1,5	20	2,8	450/30	300/20
7033M20	7033AM20	M20x1,5	24	3,5	250/25	200/20
7033M25	7033AM25	M25x1,5	29	4,0	160/20	120/15
7033M32	7033AM32	M32x1,5	36	4,0	105/15	84/12
7033M40	7033AM40	M40x1,5	45	5,0	60/15	40/10
7033M50	7033AM50	M50x1,5	57	5,0	40/10	28/7
7033M63	7033AM63	M63x1,5	70	5,5	32/8	20/5

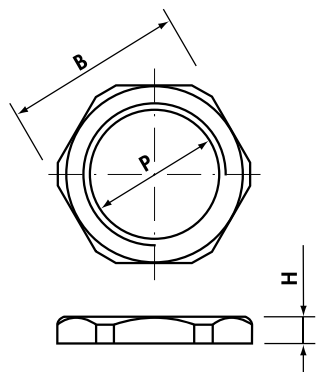

Pg thread DIN 40 430

Stainless Steel AISI 303	Stainless Steel AISI 316L	P	B Spanner (mm)	H (mm)	AISI 303 Quantity Box/Bag	AISI 316L Quantity Box/Bag
7032007	7032A007	Pg 7	16	2,8	450/30	300/20
7032009	7032A009	Pg 9	20	2,8	450/30	300/20
7032011	7032A011	Pg11	22	3,0	300/30	200/20
7032013	7032A013	Pg13,5	22	3,0	300/30	200/20
7032016	7032A016	Pg16	27	3,0	240/30	160/20
7032021	7032A021	Pg21	32	3,5	160/20	150/15
7032029	7032A029	Pg29	41	4,0	60/15	40/10
7032036	7032A036	Pg36	50	5,0	40/10	28/7
7032042	7032A042	Pg42	60	5,0	40/10	20/5
7032048	7032A048	Pg48	64	5,5	32/8	20/5



For cable glands type:

MAXIblock[®]
MAXIbrass[®]
MAXIinox



Material: POLYAMIDE PA6.6
 self-extinguishing class V2 (UL 94)
 Temperature range:
 -20°C to +90°C (continuous)
 Colour: RAL 9005 black

Application:
 Blanking the cable entry of cable glands and maintaining IP 68.

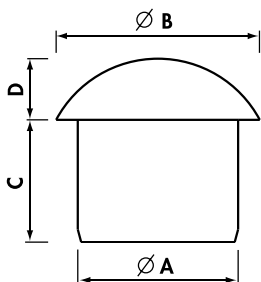

Plugs

Type	Suitable for		Ø A (mm)	Ø B (mm)	C (mm)	D (mm)	Quantity Box/Bag
	MAXIblock [®]	MAXIbrass [®] MAXIinox					
TCP5	M12R + Pg7R	M12R	4,5	8,5	10,8	4,5	3.000/100
TCP10	Pg9R	Pg9R	6,0	12,0	12,0	4,5	2.000/100
TCP12	M12 + Pg7	M12 + Pg7	6,8	12,0	12,0	4,5	1.000/100
	M16R + Pg11R	M16R + Pg11R					
TCP15	Pg9	Pg9	8,0	11,0	11,5	5,0	1.500/100
TCP18	M16 + Pg11	M16 + Pg11	9,5	12,5	13,0	5,0	800/100
TCP20	M20R	M20R	10,0	15,0	14,0	6,0	800/100
	Pg13,5 + Pg13,5R	Pg13 + Pg13,5R					
	Pg16R	Pg16R					
TCP25	M20 + Pg16	M20 + Pg16	12,5	17,0	15,0	8,0	400/100
TCP30	M25R + M32R	M25R + M32R	12,5	22,5	18,0	9,0	300/100
	Pg21R	Pg21R					
TCP35	M25 + Pg21	M25 + Pg21	16,0	19,5	18,0	8,0	300/100
TCP40	M32	M32	19,0	22,5	19,0	9,0	150/50
TCP45	M40R + Pg29 + Pg36R	M40R + Pg29	22,0	30,0	20,0	10,0	100/50
TCP50	M40 + M50R + Pg42R	M40 + M50R	27,5	38,0	25,0	12,0	50/25
TCP55	Pg36	Pg36	31,5	36,5	23,5	12,0	50/25
TCP60	M50	M50	34,5	40,0	23,5	12,0	50/25
TCP65	M63R + Pg42 + Pg48R	M63R + Pg42	37,5	48,0	26,5	12,0	30/15
TCP70	M63 + Pg48	M63 + Pg48	43,0	48,0	26,5	12,0	30/15

R: reduced cable entry

MULTI-ENTRY SEALS FOR CABLE GLANDS

Neoprene® 70 sh A

For cable glands type:

MAXIblock®
MAXIbrass®
MAXIinox®

Material: NEOPRENE® 70 sh A
Temperature range:
-40°C to +130°C
Protection: IP 68
Colour: RAL 9005 black

Application:
IP68 sealing of multiple cables
entering cable glands.



36A
36C

Multi-entry seals

Type	Suitable for		No. entries	Ø entries (mm)	Quantity Box/Bag
	MAXIblock®	MAXIbrass® MAXIinox®			
36A3M1623	M16 + Pg11	M16 + Pg11	2	3,0	500/100
36A3M1624	M16 + Pg11	M16 + Pg11	2	4,0	1.000/100
36A3M16322	M16 + Pg11	M16 + Pg11	3	2,2	1.000/100
36A3M2025	M20 + Pg13,5	M20 + Pg13,5 + Pg16	2	5,0	500/100
36A3M2026	M20 + Pg13,5	M20 + Pg13,5 + Pg16	2	6,0	500/100
36A3M2034	M20 + Pg13,5	M20 + Pg13,5 + Pg16	3	4,0	500/100
36A3M2035	M20 + Pg13,5	M20 + Pg13,5 + Pg16	3	5,0	500/100
36A3M20356	M20 + Pg13,5	M20 + Pg13,5 + Pg16	3	5,6	500/100
36A3M2526	M25	M25 + Pg21	2	6,0	300/50
36A3M2536	M25	M25 + Pg21	3	6,0	300/50
36A3M2537	M25	M25 + Pg21	3	7,0	300/50
36A3M2545	M25	M25 + Pg21	4	5,0	300/50
36A3M2546	M25	M25 + Pg21	4	6,0	300/50
36A3M2554	M25	M25 + Pg21	5	4,0	300/50
36C3M252105	M25	M25 + Pg21	2	5+10,5	300/50
36A3M3228	M32	M32	2	8,0	150/50
36A3M3239	M32	M32	3	9,0	150/50
36A3M32465	M32	M32	4	6,5	150/50
36A3M3248	M32	M32	4	8,0	150/50
36A3M4078	M40	M40	7	8,0	100/100
36A3M40106	M40	M40	10	6,0	100/100
36A3M5088	M50 + Pg 36	M50 + Pg 36	8	8,0	50/50
36C201629	Pg16	-	2	3+9	400/50

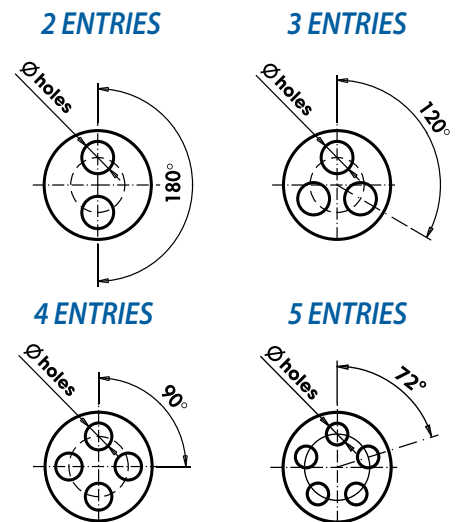

MULTI-ENTRY SEAL PLUGS FOR CABLE GLANDS

Polyamide PA6.6

Material: POLYAMIDE PA6.6
Temperature range:
-20°C to +90°C (continuous)
Colour: RAL 7035 light grey

Application:
Plugging unused entries in multi-entry seals and maintaining IP68.



TGM

Multi-entry seal plugs

Type	Suitable for Seal	Ø A (mm)	L (mm)	Quantity Box/Bag
TGM38	36A3M1623	3	10	5.000/100
TGM48	36A3M1624 + 36A3M2034 + 36A3M2554	4	8	5.000/100
TGM58	36A3M2025	5	8	5.000/100
TGM513	36A3M2545	5	13	2.500/50
TGM613	36A3M2526 + 36A3M2536 + 36A3M40106	6	13	2.000/50
TGM713	36A3M2537	7	13	2.000/50
TGM817	36A3M3248 + 36A3M5088 + 36A3M4078	8	17	100

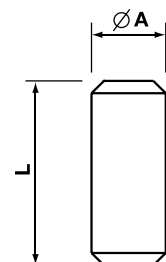

2093
2043
20A4

ENTRY THREAD ADAPTERS

Nickel Plated Brass

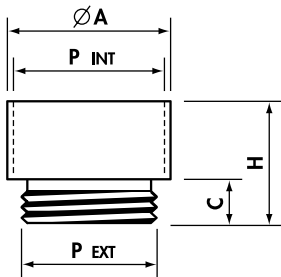

Fig. 1

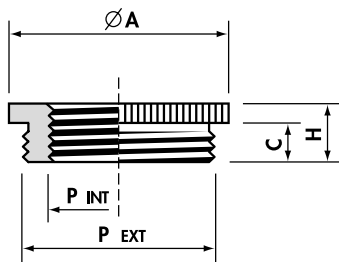

Fig. 2

Entry thread enlargers

Metric thread M 1.5 pitch CEI EN 60423

Type	P EXT	P INT	Ø A (mm)	C (mm)	H (mm)	Quantity Box/Bag
20931216N	M12x1,5	M16x1,5	18	5	15,5	500/100
20931620N	M16x1,5	M20x1,5	22	5	17,5	300/100
20932025N	M20x1,5	M25x1,5	27	6	20,0	150/50
20932532N	M25x1,5	M32x1,5	34	7	22,5	100/50
20932540N	M25x1,5	M40x1,5	42	7	23,5	50/50
20933240N	M32x1,5	M40x1,5	42	8	24,5	50/50
20933250N	M32x1,5	M50x1,5	52	8	27,5	25/25
20934050N	M40x1,5	M50x1,5	52	8	27,5	25/25
20935063N	M50x1,5	M63x1,5	66	9	31,0	20/10

Entry thread reducers

Metric thread M 1.5 pitch CEI EN 60423

Type	P EXT	P INT	Ø A (mm)	C (mm)	H (mm)	Quantity Box/Bag
20431612N	M16x1,5	M12x1,5	18	5	7,5	1.000/100
20432012N	M20x1,5	M12x1,5	22	6	9,0	600/100
20432016N	M20x1,5	M16x1,5	22	6	9,0	500/100
20432512N	M25x1,5	M12x1,5	27	7	10,0	300/50
20432516N	M25x1,5	M16x1,5	27	7	10,0	300/50
20432520N	M25x1,5	M20x1,5	27	7	10,0	300/100
20433220N	M32x1,5	M20x1,5	34	8	11,0	100/25
20433225N	M32x1,5	M25x1,5	34	8	11,0	200/50
20434025N	M40x1,5	M25x1,5	43	8	11,5	100/25
20434032N	M40x1,5	M32x1,5	43	8	11,5	100/25
20435032N	M50x1,5	M32x1,5	53	9	12,5	50/10
20435040N	M50x1,5	M40x1,5	53	9	12,5	50/25
20436340N	M63x1,5	M40x1,5	66	10	14,0	30/10
20436350N	M63x1,5	M50x1,5	66	10	14,0	30/10

Entry thread converters - Metric to Pg

Type	P EXT	P INT	Fig.	Ø A (mm)	C (mm)	H (mm)	Quantity Box/Bag
20A42011N	M20x1,5	Pg11	1	22	6,5	17,5	300/100
20A42016N	M20x1,5	Pg16	1	24	6,5	20,0	200/50
20A42513N	M25x1,5	Pg13,5	2	27	7,0	10,0	300/50
20A42516N	M25x1,5	Pg16	2	27	7,0	10,0	300/50
20A43216N	M32x1,5	Pg16	2	36	8,0	11,5	100/25
20A43221N	M32x1,5	Pg21	2	36	8,0	11,5	100/25

Entry thread converters - Pg to Metric

20A40916N	Pg 9	M16x1,5	1	20	6,0	15,0	400/100
20A41120N	Pg11	M20x1,5	1	22	6,0	16,0	300/100
20A41320N	Pg13,5	M20x1,5	1	24	6,5	16,5	200/50
20A41620N	Pg16	M20x1,5	2	24	6,5	9,5	50/50
20A42120N	Pg21	M20x1,5	2	30	7,0	10,0	100/100
20A42125N	Pg21	M25x1,5	2	30	7,0	10,0	100/100
20A42925N	Pg29	M25x1,5	2	39	8,0	11,5	50/50

ENTRY THREAD ADAPTERS

Nickel Plated Brass

1800
2042

Entry thread enlargers

Pg thread DIN 40 430 - Dimensions DIN 46 320-K

Type	P EXT	P INT	Ø A (mm)	C (mm)	H (mm)	Quantity Box/Bag
180709	Pg 7	Pg 9	17	5,0	15,0	600/100
180911	Pg 9	Pg11	20	6,0	16,5	500/100
180913	Pg 9	Pg13,5	22	6,0	17,5	300/100
181113	Pg11	Pg13,5	22	6,0	17,5	300/100
181116	Pg11	Pg16	24	6,0	18,5	100/50
181316	Pg13,5	Pg16	24	6,5	19,0	200/50
181321	Pg13,5	Pg21	30	6,5	21,0	150/50
181621	Pg16	Pg21	30	6,5	21,0	100/25
182129	Pg21	Pg29	39	7,0	23,0	75/25
182936	Pg29	Pg36	50	8,0	27,5	30/10
183642	Pg36	Pg42	57	9,0	31,0	20/10
184248	pg42	pg48	64	10,0	33,0	20/10

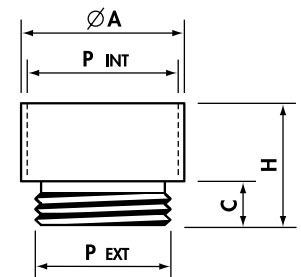

Entry thread reducers

Pg thread DIN 40 430 - Dimensions DIN 46 320-H

Type	P EXT	P INT	Ø A (mm)	C (mm)	H (mm)	Quantity Box/Bag
20420907N	Pg 9	Pg 7	17	6,0	8,5	800/100
20421107N	Pg11	Pg 7	20	6,0	8,5	600/100
20421109N	Pg11	Pg 9	20	6,0	8,5	600/100
20421307N	Pg13,5	Pg 7	22	6,5	9,0	600/100
20421309N	Pg13,5	Pg 9	22	6,5	9,0	600/100
20421311N	Pg13,5	Pg11	22	6,5	9,0	600/100
20421607N	Pg16	Pg 7	24	6,5	9,5	300/50
20421609N	Pg16	Pg 9	24	6,5	9,5	400/100
20421611N	Pg16	Pg11	24	6,5	9,5	400/100
20421613N	Pg16	Pg13,5	24	6,5	9,5	400/100
20422111N	Pg21	Pg11	30	7,0	10,0	200/50
20422113N	Pg21	Pg13,5	30	7,0	10,0	200/50
20422116N	Pg21	Pg16	30	7,0	10,0	200/50
20422916N	Pg29	Pg16	39	8,0	11,5	100/25
20422921N	Pg29	Pg21	39	8,0	11,5	100/25
20423621N	Pg36	Pg21	50	9,0	12,5	50/25
20423629N	Pg36	Pg29	50	9,0	12,5	50/25
20424236N	Pg42	Pg36	57	10,0	14,0	50/25
20424836N	Pg48	Pg36	64	10,0	14,0	25/25
20424842N	Pg48	Pg42	64	10,0	14,0	50/25

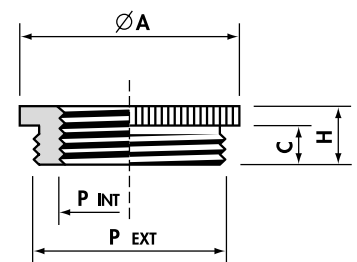



Material:
Zinc plated STEEL UNI 5961/84

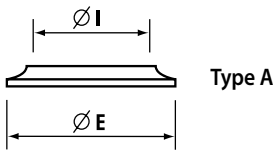

Type A

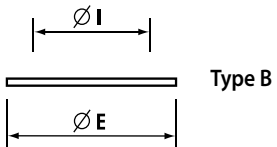

Type B

Compression washers

Type	Fits thread	$\varnothing E$ (mm)	$\varnothing I$ (mm)	Quantity Box/Bag
6010.14	Pg7 + G1/4"	11,0	8,0	15.000/1.000
6010.38	Pg9 + G3/8"	14,5	10,0	5.000/1.000
6010.11	Pg11 + G3/8"	17,0	12,0	5.000/1.000
6010.12	Pg13,5 + G1/2"	18,0	14,0	4.000/1.000
6010.58	Pg16 + G5/8"	20,0	15,5	3.000/1.000
6010.34	G3/4"	24,0	18,5	2.500/500
6010.114	G1"1/4	38,0	33,0	1.000/500
6010.21	Pg21 + G3/4"	26,5	20,0	2.000/500
6010.01	G1"	30,0	24,5	1.500/500
6010.29	Pg29 + G1"1/8	35,0	26,5	1.000/500
6010.36	Pg36 + G1"1/2	45,0	38,0	750/250
6010.42	Pg42	51,0	42,5	500/250
6010.48	Pg48 + G2"	57,0	48,0	400/100

Subject to availability, the compression washers could be of type A or B

SEALING RINGS

Butadiene-Nitrile NBR

1880
1890



Material:
BUTADIENE-NITRILE NBR
with concentric perforations

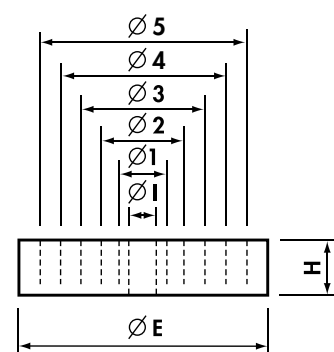

Concentric sealing rings

Type	Suitable for Cable Glands IP54 (1700..., 2001..., 2002..., 2003...)	Ø E (mm)	Ø 5 (mm)	Ø 4 (mm)	Ø 3 (mm)	Ø 2 (mm)	Ø 1 (mm)	Ø 1 (mm)	H (mm)	Quantity Box/Bag
1880	Pg9 + M16	13,3	-	-	-	10,0	7,5	5,0	5,5	1.500/100
1881	Pg11	16,5	-	-	-	12,5	10,0	7,5	6,0	1.000/100
1882	Pg13,5 + M20 + G1/2"	18,3	-	-	-	12,5	10,0	7,5	6,0	800/100
1883	Pg16 + G5/8"	20,4	-	-	15,0	12,5	10,0	7,5	7,0	600/100
1884	Pg21 + M25	26,0	-	-	19,0	16,0	13,0	10,0	8,0	300/100
1884A	Pg21 + M25	26,0	-	-	20,5	18,0	15,0	10,5	8,0	50/25
1885*	Pg29 + M32 + G1 1/8"	34,7	-	-	27,0	24,0	21,0	18,0	9,5	150/50
1886	Pg36 + G1 1/2 + M40	44,7	-	-	33,0	30,0	27,0	24,0	12,0	100/50
1887*	Pg42 + M50	51,7	-	-	39,0	36,0	33,0	30,0	14,0	50/25
1888/5	Pg48 + G2" + M63	57,0	45	41	37,0	33,0	29,0	24,0	14,0	75/25
1888*	Pg48 + G2" + M63	57,0	-	-	45,0	42,0	39,0	36,0	14,0	50/25

*material: RUBBER NR

O-rings

Type	Fits thread	Ø E (mm)	Ø I (mm)	Ø H (mm)	Quantity Box/Bag
1889	M12	12,81	9,25	1,78	1.000/1.000
1890	Pg7 + G1/4"	14,38	10,82	1,78	5.000/1.000
1890A	M16 + Pg9 + G3/8"	15,98	12,42	1,78	5.000/1.000
1891	Pg11	19,16	15,60	1,78	5.000/1.000
1891A	M20	20,73	17,17	1,78	5.000/1.000
1892	Pg13,5 + G1/2"	22,33	18,77	1,78	5.000/1.000
1892A	Pg16 + G5/8"	23,91	20,35	1,78	5.000/1.000
1892B	M25	25,51	21,95	1,78	5.000/1.000
1893	Pg21	28,68	25,12	1,78	3.000/500
1893A	M32	30,00	26,00	2,00	500/500
1925.3	G3/4"	30,31	25,07	2,62	1.000/500
1894	G1"	35,06	29,82	2,62	1.000/500
1895	M40 + Pg29 + G1 1/8"	39,84	34,60	2,62	1.000/500
1896	G1 1/4"	43,01	37,77	2,62	500/500
1897	Pg36 + G1 1/2"	49,36	44,12	2,62	800/100
1898	Pg42 + G1 3/4"	55,71	50,47	2,62	800/100
1899	Pg48 + G2"	62,06	56,82	2,62	100
1899A	G2 1/2"	76,50	69,44	3,53	100/1
1899B	G3"	92,60	81,92	5,34	100/1



Material:
Butadiene-Nitrile 70 sh

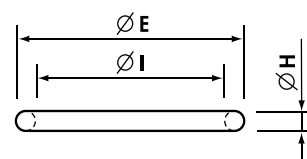

341
342
343
344

SEALING RINGS

PVC 50 sh A



Material: PVC 50 sh A
Colour: Red

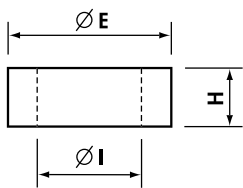

Cylindrical sealing rings

Type	Suitable for Cable Glands IP54 (1700., 2001., 2002., 2003..)	C (mm)	ØE (mm)	ØI (mm)	H (mm)	Quantity Box/Bag
3411014	G1/4"	-	10,9	6,7	6,0	1.500/100
3411038	G3/8" + M16	-	14,5	8,5	6,0	1.000/100
3411012	Pg13,5 + G1/2" + M20	-	18,0	11,0	7,5	500/100
3412016	Pg16 + G5/8"	-	20,0	14,0	7,5	300/100
3422016	Pg16 + G5/8"	-	20,0	10,0	7,5	300/100
3411034	G3/4"	-	23,5	17,5	8,0	300/100
3411100	G1"	-	29,0	22,0	10	200/100
3412011	Pg11	-	16,5	10,0	7,0	1.000/100
3412021	Pg21 + M25	-	26,0	18,0	8,5	300/100
3412029	Pg29 + G1"1/8 + M32	-	35,0	26,0	10,0	200/100

Membrane sealing rings

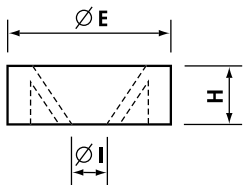

Type	Suitable for Cable Glands IP54 (1700., 2001., 2002., 2003..)	C (mm)	ØE (mm)	ØI (mm)	H (mm)	Quantity Box/Bag
3431100	G1"	-	29	15	9,5	200/100

Double sealing rings

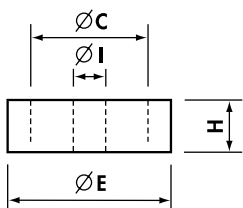

Type	Suitable for Cable Glands IP54 (2001., 2002., 2003..)	C (mm)	ØE (mm)	ØI (mm)	H (mm)	Quantity Box/Bag
3441012	G1/2" + Pg13,5 + M20	13	18,5	8	6,5	500/100
3441034	G3/4"	17	23	12,5	8,5	300/100

SEALING RINGS

Butadiene-Stirene SBR 70shA

Type	Fits thread	Ø E (mm)	Ø I (mm)	H (mm)	Quantity Box/Bag
3572007	Pg7	16,5	11,5	1,0	4.000/100
3572011	Pg11	23,0	17,5	1,0	2.500/100
35720131	Pg13,5 + M20X1,5 + G1/2"	27,5	20,5	1,4	1.000/100
3572013	Pg13,5	30,0	20,5	2,2	1.000/100
3572016	Pg16	29,0	23,0	2,0	1.000/100
3572021	Pg21	33,5	27,0	3,0	500/100
3573M16	M16x1,5	20,5	16,3	1,0	3.000/100
3573M20	M20X1,5 + Pg13,5 + G1/2"	25,5	20,5	1,0	4.000/100
3573M25	M25x1,5	30,5	25,5	1,0	2.000/100
3573M32	M32x1,5	40,5	32,5	1,0	1.500/100

357

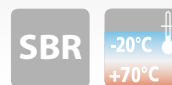

Material:
BUTADIENE-STIRENE SBR 70 sh A
Temperature range: -20°C to +70°C
Colour: RAL 7035 light grey

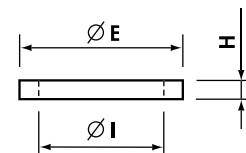

SEALING RINGS

Neoprene® 80 sh A

Type	Fits thread	Ø E (mm)	Ø I (mm)	H (mm)	Quantity Box/Bag
FD M12	M12	16,0	10,0	1,2	2.500/50
FD 7	Pg7 + G1/4"	17,0	11,3	1,2	3.000/50
FD 9	Pg9 + M16	20,0	13,9	1,2	2.000/50
FD M16	M16* + G3/8"	20,0	15,5	1,2	2.000/50
FD 11	Pg11	23,0	17,1	1,2	2.000/50
FD M20	M20	24,0	18,0	1,2	2.000/50
FD 13,5	Pg13,5 + G1/2"	25,0	19,0	1,2	2.500/50
FD 16	Pg16 + G5/8"	27,0	21,0	1,2	1.500/50
FD M25	M25	31,0	23,0	1,2	1.000/20
FD 21	Pg21 + G3/4"	34,5	27,0	1,5	1.000/25
FD M32	M32 + G1"	36,0	30,0	1,3	600/20
FD 29	Pg29 + G1"1/8"	45,0	35,2	1,5	500/25
FD M40	M40 + G1"1/4"	46,0	38,0	1,2	500/20
FD 36	Pg36 + G1"1/2"	53,5	45,6	1,2	250/25
FD M50	M50	55,0	47,5	1,1	10
FD 42	Pg42 + G1"3/4"	62,0	52,0	1,1	10
FD 48	Pg48 + G2"	68,0	58,0	1,1	10
FD M63	M63	68,0	59,0	1,1	500/5

*recommended with set screws

FD



Material:
NEOPRENE® 80 sh A
Temperature range: -25°C to +100°C
Colour: RAL 9005 black

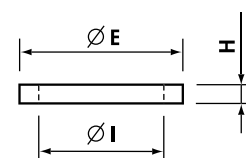

1053

1052

ENTRY PLUGS

Polyamide PA6



Material: POLYAMIDE PA6
 reinforced with fibreglass
 self-extinguishing class HB (UL 94)
 Temperature range:
 -20°C to +90°C (continuous)
 Protection: IP 54
 Colour: RAL 7035 light grey,
 RAL 9005 black

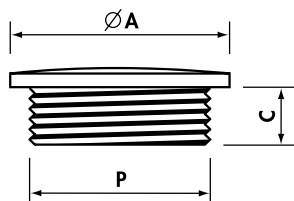

Metric thread M 1.5 pitch CEI EN 60423

Type Light Grey	P	Ø A (mm)	C (mm)	Quantity Box/Bag
1053M12	M12x1,5	15	6	100
1053M16	M16x1,5	20	6	100
1053M20	M20x1,5	25	7	100
1053M25	M25x1,5	30	7	100
1053M32	M32x1,5	37	9	50
1053M40	M40x1,5	47	9	30
1053M50	M50x1,5	58	10	20
1053M63	M63x1,5	72	12	10

Add to Ref: N for Black

Pg thread DIN 40 430 - Dimensions DIN 46 320

Type Light Grey	P	Ø A (mm)	C (mm)	Quantity Box/Bag
1052007	Pg 7	15	6	100
1052009	Pg 9	19	6	100
1052011	Pg11	22	7	100
1052013	Pg13,5	25	7	100
1052016	Pg16	27	7	100
1052021	Pg21	33	9	50
1052029	Pg29	44	9	100/50
1052036	Pg36	55	10	20
1052042	Pg42	62	10	10
1052048	Pg48	69	12	10

Add to Ref: N for Black

ENTRY PLUGS

Polystyrene PS

1253
1840



Material: POLYSTYRENE PS
Temperature range:
-20°C to +60°C (continuous)
Protection: IP 54
Colour: RAL 7035 light grey,
RAL 9005 black

Metric thread M 1.5 pitch CEI EN 60423

Type Light Grey	P	Ø A (mm)	C (mm)	Quantity Box/Bag
1253M12	M12x1,5	15	6	100
1253M16	M16x1,5	20	6	100
1253M20	M20x1,5	25	7	100
1253M25	M25x1,5	30	7	100
1253M32	M32x1,5	37	9	50
1253M40	M40x1,5	47	9	30
1253M50	M50x1,5	58	10	20
1253M63	M63x1,5	72	12	10

Add to Ref: N for Black

Pg thread DIN 40 430 - Dimensions DIN 46 320

Type Light Grey	P	Ø A (mm)	C (mm)	Quantity Box/Bag
1840	Pg 7	15	6	100
1841	Pg 9	19	6	100
1842	Pg11	22	7	100
1843	Pg13,5	25	7	100
1844	Pg16	27	7	100
1845	Pg21	33	9	50
1846	Pg29	44	9	100/50
1847	Pg36	55	10	20
1848	Pg42	62	10	10
1849	Pg48	69	12	10

Add to Ref: N for Black

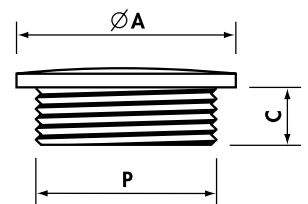



Material: POLYAMIDE PA6
 self-extinguishing class V0 (UL 94)
 Temperature range:
 -20°C to +90°C (continuous)
 Colour: RAL 7035 light grey,
 RAL 9005 black

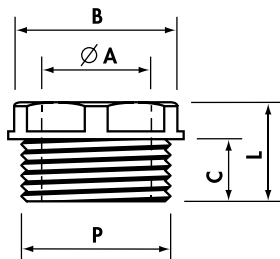

Entry bushes

Pg thread DIN 40 430 - Dimensions DIN 46 320

Type Light Grey	P	Ø A (mm)	B Spanner (mm)	C (mm)	L min-max (mm)	Quantity Box/Bag
1700.2*	Pg 9	10,0	16	9,0	14,0	600/100
1701.2*	Pg11	11,5	19	10,0	15,0	300/100
1702.2*	Pg13,5	13,5	21	11,0	16,5	300/100
1703.2	Pg16	16,0	23	12,5	18,5	200/100
1704.2	Pg21	22,0	30	12,0	17,5	100/50
1705.2	Pg29	27,0	40	15,0	22,0	50/50

BSP thread ISO 228/1

Type Light Grey	P	Ø A (mm)	B Spanner (mm)	C (mm)	L min-max (mm)	Quantity Box/Bag
1830*	G1/4"	8,5	15	8,5	13,5	800/100
1831*	G3/8"	11,5	17	9,0	14,0	300/100
1832*	G1/2"	13,0	21	11,0	16,5	300/100

Metric thread M 1.5 pitch CEI EN 60423

Type Light Grey	P	Ø A (mm)	B Spanner (mm)	C (mm)	L min-max (mm)	Quantity Box/Bag
Δ 1835G	M16x1,5	11,5	17	9	14,0	100/100
1836*	M20x1,5	13,5	21	11	16,5	300/100

*Add to Ref: N for Black

Δ Dark Grey only

Blind entry bushes

Pg thread DIN 40 430 - Dimensions DIN 46 320

Type Light Grey	P	Ø A (mm)	B Spanner (mm)	C (mm)	L min-max (mm)	Quantity Box/Bag
1702.5*	Pg13,5	-	21	11,0	17,0	300/100
1703.5	Pg16	-	23	12,5	18,5	200/100

BSP thread ISO 228/1

Type Light Grey	P	Ø A (mm)	B Spanner (mm)	C (mm)	L min-max (mm)	Quantity Box/Bag
1861*	G3/8"	-	17	9	14	600/100
1862*	G1/2"	-	21	11	16,5	200/100

Metric thread M 1.5 pitch CEI EN 60423

Type Light Grey	P	Ø A (mm)	B Spanner (mm)	C (mm)	L min-max (mm)	Quantity Box/Bag
1866*	M20x1,5	-	21	11	17	100

*Add to Ref: N for Black

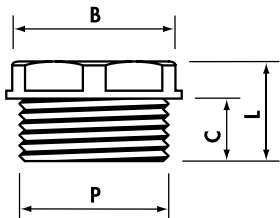

ENTRY PLUGS

Nickel Plated Brass

Metric thread M 1.5 pitch CEI EN 60423

Type Nickel Plated Brass	P	Ø A (mm)	C (mm)	Quantity Box/Bag
2053M12N	M12x1,5	14	5,0	1.500/100
2053M16N	M16x1,5	18	5,0	1.000/100
2053M20N	M20x1,5	22	6,5	500/100
2053M25N	M25x1,5	28	7,0	200/100
2053M32N	M32x1,5	35	8,0	150/25
2053M40N	M40x1,5	44	8,5	100/25
2053M50N	M50x1,5	54	9,0	50/25
2053M63N	M63x1,5	67	10,0	25/25

Pg thread DIN 40 430 - Dimensions DIN 46 320

Type Nickel Plated Brass	P	Ø A (mm)	C (mm)	Quantity Box/Bag
2052007N	Pg 7	14	5,0	1.500/100
2052009N	Pg 9	17	6,0	1.000/100
2052011N	Pg11	20	6,0	500/100
2052013N	Pg13,5	22	6,5	500/100
2052016N	Pg16	24	6,5	500/100
2052021N	Pg21	30	7,0	200/50
2052029N	Pg29	39	8,0	100/25
2052036N	Pg36	50	9,0	50/25
2052042N	Pg42	57	10,0	25/25
2052048N	Pg48	64	10,0	25/25

ENTRY BUSHES

Brass

BSP thread ISO 228/1

Type Brass	P	Ø A (mm)	B Spanner (mm)	C (mm)	L min-max (mm)	Quantity Box/Bag
2021014	G1/4"	10,0	13	6,0	8,5	1.000/100
2021038	G3/8"	12,0	17	7,5	10,5	800/100
2021012	G1/2"	16,0	21	9,5	13,0	400/100
2021058	G5/8"	18,0	23	10,0	13,5	250/50
2021034	G3/4"	21,0	27	10,0	14,0	200/50
2021100	G1"	26,5	34	11,0	15,5	100/50
2021118	G1"1/8	31,0	38	12,0	16,5	100/25
2021114	G1"1/4	35,0	42	13,0	18,0	50/25
2021112	G1"1/2	41,5	48	13,0	18,5	50/25
2021200	G2"	51,5	60	13,5	19,5	25/25

Add to Ref: N for NICKEL PLATED BRASS

2053
2052

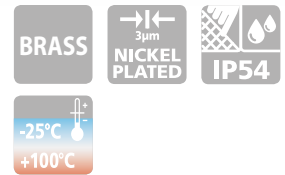

Material: NICKEL PLATED BRASS
(CuZn 40 Pb 3)
Protection: IP 54

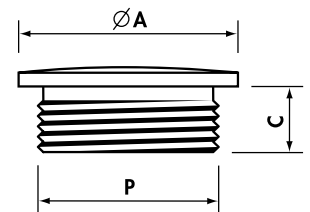

2021



Material: PLAIN BRASS

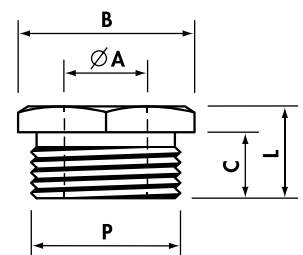

RS

RUTASEAL GROMMETS

Rubber EPDM

Fits Metric thread



HF
HALOGEN
FREE



Material: Rubber EPDM halogen-free and chemical resistant
 Temperature range: -40°C to +110°C
 Protection: IP 67
 Colour: RAL 7001 light grey
 Application:
 IP67 sealing of cables and conduits in Metric and Pg threaded entries through material thickness 0,5-4 mm

Type	Fits Threaded Entry	A (mm)	B (mm)	C (mm)	D (mm)	E (mm)	Quantity Box/Bag
RS0407.M12	M12	12,5	0,5 - 2	5,6	20,0	4 - 7	2.000/50
RS0509.M16	M16	16,5	1 - 4	11,0	21,0	5 - 9	2.000/50
RS0813.M20	M20/Pg13,5	20,5	1 - 4	13,4	25,5	8 - 13	3.000/50
RS1117.M25	M25	25,5	1 - 4	15,3	30,5	11 - 17	2.000/50
RS1520.M32	M32	32,5	1 - 4	18,6	38,5	15 - 20	1.000/25
RS1928.M40	M40	40,5	1 - 4	21,7	48,5	19 - 28	600/25
RS2735.M50	M50	50,5	1 - 4	25,0	60,5	27 - 35	250/10

Fits Pg thread

Type	Fits Threaded Entry	A (mm)	B (mm)	C (mm)	D (mm)	E (mm)	Quantity Box/Bag
RS0305.07	Pg 7	12,5	0,5 - 2	5,4	20,0	3 - 5	2.000/50
RS0507.09	Pg 9	16,0	1 - 4	10,3	21,0	5 - 7	2.000/50
RS0710.11	Pg11	19,0	1 - 4	12,7	24,0	7 - 10	3.000/50
RS1014.16	Pg16	23,0	1 - 4	14,7	28,0	10 - 14	2.000/50
RS1420.21	Pg21	29,0	1 - 4	17,6	35,0	14 - 20	1.000/25
RS2026.29	Pg29	38,0	1 - 4	20,0	46,0	20 - 26	600/25
RS2635.36	Pg36	48,0	1 - 4	23,9	58,0	26 - 35	250/10

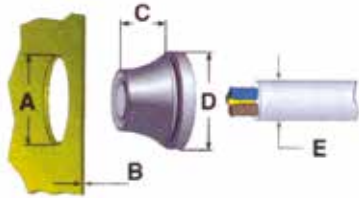

3600

MODULAR RETAINING CLIPS

ABS

SICUR[®]
clips



Material: ABS self-extinguishing class V0 (UL94) UV stabilised
 Glow wire resistance:
 750° C (CEI EN 60695-2-1)
 Temperature range:
 -20°C to +80°C (continuous)
 Colour: RAL 7035 light grey

Application: Fix SICURclip base to surface using dia. 5 - 6 mm screw (Ref. Fig. A).
 Insert cable, tubing or flexible conduit.
 Fit adjustable cover and press to secure.
 Modular SICURclips of the same or different size may easily be joined together.

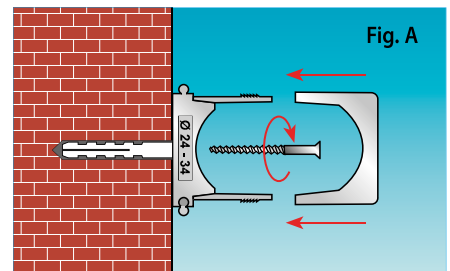

Type	Ø A min-max (mm)	H (mm)	S (mm)	Quantity
3601	13-21	8,5	16	100
3602	24-34	8,5	16	50
3603	38-50	8,5	16	25

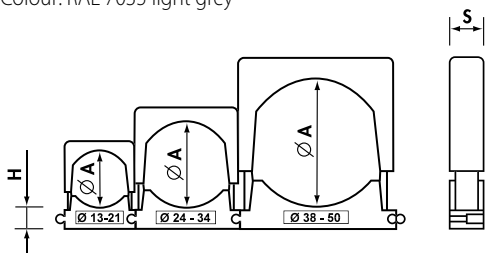



MECHANICAL AND PNEUMATIC TOOLS

symbol description

professional mechanical tools - hydraulic bench press



Can be operated with one hand



Hexagonal crimp



Manual pressure release button



Radial crimp



Ergonomically designed with a sculptured body for operator comfort



Indent crimp



Lightweight and balanced for greater control



Indent crimp



Dual-compound plastic handles
Greater safety and comfort in handling, thanks to the rubber inserts



Oval crimp



Durable moulded body offering high resistance to wear and damage in all operating conditions



Trapezium crimp



Extremely quiet in operation



Rhomboidal crimp



Protected against accidental intrusions



Square crimp

symbol description

professional mechanical tools - hydraulic bench press



Operating temperature range



Halogen free



USL-CNL Marking valid in USA & CANADA



CE marking



CRIMPSTAR®

Manual tool, compact and easy to use, equipped with:

- treated steel crimp jaws with high mechanical properties.
- factory-set ratchet for crimping control (automatic handle opening upon completion of crimping operation).
- Emergency release lever which, if necessary, opens the crimp jaws before their complete closure.
- Ergonomically designed non-slip moulded plastic grips.

HP1

MECHANICAL TOOLS CRIMPSTAR® RANGE

for insulated terminals and connectors



Crimpstar®



TECHNICAL FEATURES:

Crimping Range	PVC, PC and PA6.6 insulated terminals and connectors for conductor sizes 0,2 to 2,5 sqmm
Dimensions mm	
Length	234,5
Width	73,0
Height	18,3
Weight g	512
Package Dimensions	240 x 81 x 25

HP3

MECHANICAL TOOLS CRIMPSTAR® RANGE

for insulated terminals and connectors



Crimpstar®



TECHNICAL FEATURES:

Crimping Range	PVC, PC and PA6.6 insulated terminals and connectors for conductor sizes 0,25 to 6 sqmm
Dimensions mm	
Length	234,5
Width	73,0
Height	18,3
Weight g	498
Package Dimensions	240 x 81 x 25

MECHANICAL TOOLS CRIMPSTAR® RANGE

HNN3

for insulated terminals and connectors

Crimpstar®



TECHNICAL FEATURES

Crimping Range	PA6.6 insulated terminals and connectors for conductor sizes 1,5 to 10 sqmm
Dimensions mm	
Length	234,5
Width	73,0
Height	18,3
Weight g	491
Package Dimensions	240 x 81 x 25



MECHANICAL TOOLS CRIMPSTAR® RANGE

HNN4

for insulated terminals and connectors

Crimpstar®



TECHNICAL FEATURES

Crimping Range	PA6.6 insulated terminals and connectors for conductor sizes 10 and 16 sqmm
Dimensions mm	
Length	234,5
Width	73,0
Height	18,3
Weight g	492
Package Dimensions	240 x 81 x 25



HPH1

MECHANICAL TOOLS CRIMPSTAR® RANGE

for through connectors PE HD insulated, heat shrinkable



TECHNICAL FEATURES

Crimping Range

Through connectors PE HD insulated, heat shrinkable.
for conductor sizes 0,5 to 6 sqmm and PA6.6 connectors NL-M, NL-P
for conductor sizes 0,25 to 6 sqmm

Dimensions mm

Length	234,5
Width	73,0
Height	18,3
Weight g	512
Package Dimensions	240 x 81 x 25

HNKE4

MECHANICAL TOOLS CRIMPSTAR® RANGE

for end sleeves



Crimpstar®

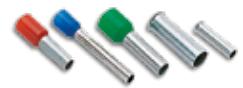

TECHNICAL FEATURES

Crimping Range

End sleeves
for conductor sizes 0,5 to 4 sqmm

Dimensions mm

Length	234,5
Width	73,0
Height	18,3
Weight g	498
Package Dimensions	240 x 81 x 25

MECHANICAL TOOLS CRIMPSTAR® RANGE

HNKE16

for end sleeves

Crimpstar®



TECHNICAL FEATURES

Crimping Range	End sleeves for conductor sizes 4 to 16 sqmm
Dimensions mm	
Length	236
Width	73,0
Height	18,3
Weight g	491
Package Dimensions	240 x 81 x 25



MECHANICAL TOOLS CRIMPSTAR® RANGE

HNKE50

for end sleeves

Crimpstar®



TECHNICAL FEATURES

Crimping Range	End sleeves for conductor sizes 25 - 35 - 50 sqmm
Dimensions mm	
Length	234,5
Width	73,0
Height	18,3
Weight g	590
Package Dimensions	240 x 81 x 25



HN1

MECHANICAL TOOLS CRIMPSTAR® RANGE

for uninsulated terminals and connectors



Crimpstar®



TECHNICAL FEATURES

Crimping Range Uninsulated terminals and connectors for conductor sizes 0,25 to 10 sqmm

Dimensions mm

Length	234,5
Width	73,0
Height	18,3
Weight g	480
Package Dimensions	240 x 81 x 25

HN5

MECHANICAL TOOLS CRIMPSTAR® RANGE

for uninsulated terminals and connectors



Crimpstar®



TECHNICAL FEATURES

Crimping Range Uninsulated terminals and connectors for conductor sizes 10 and 16 sqmm

Dimensions mm

Length	234,5
Width	73,0
Height	18,3
Weight g	489
Package Dimensions	240 x 81 x 25

MECHANICAL TOOLS CRIMPSTAR® RANGE

HN-A25

for uninsulated terminals and connectors A-M, L-M and L-P series

Crimpstar®



for Cu tube lugs DR (DIN 46235) and through connectors DSV (DIN 46267)

HN-D25

Crimpstar®



for Cu tube lugs HR and through connectors HSV

HN-H25

Crimpstar®



for Cu tube lugs T-M, T-L and through connectors L-T

HN-T25

Crimpstar®



HN-A25 TECHNICAL FEATURES:

Crimping Range

Uninsulated terminals and connectors A-M, L-M and L-P series
for conductor sizes 10 to 25 sqmm

HN-D25 TECHNICAL FEATURES:

Crimping Range

Cu tube lugs DR (DIN 46235) and through connectors DSV (DIN 46267)
for conductor sizes 10 to 25 sqmm

HN-H25 TECHNICAL FEATURES:

Crimping Range

Cu tube lugs HR and through connectors HSV
for conductor sizes 10 to 25 sqmm

HN-T25 TECHNICAL FEATURES:

Crimping Range

Cu tube lugs T-M, T-L and through connectors L-T
for conductor sizes 10 to 25 sqmm



Dimensions mm

Length	229
Width	78,6
Height	18,3
Weight g	500
Package Dimensions	240 x 81 x 25

HF1

MECHANICAL TOOLS CRIMPSTAR® RANGE

for open barrel brass terminals



Crimpstar®



TECHNICAL FEATURES

Crimping Range	Open barrel brass terminals for conductors sizes 0,5 to 4 sqmm (not BN-FAB/FAR type)
Dimensions mm	
Length	234,5
Width	73,0
Height	18,3
Weight g	509
Package Dimensions	240 x 81 x 25

HF2

MECHANICAL TOOLS CRIMPSTAR® RANGE

for open barrel brass terminals



Crimpstar®



TECHNICAL FEATURES

Crimping Range	Open barrel brass terminals for conductors sizes 0,08 to 1,3 sqmm (28 to 16 AWG)
Dimensions mm	
Length	234,5
Width	73,0
Height	18,3
Weight g	497
Package Dimensions	240 x 81 x 25

for coaxial connectors

Crimpstar®



TECHNICAL FEATURES

Crimping Range	Coaxial connectors type RG58, RG59, RG62 and RG 71
Dimensions mm	
Length	234,5
Width	73,0
Height	18,3
Weight g	481
Package Dimensions	240 x 81 x 25



for insulated and uninsulated end sleeves



A generation of tools, with a unique mechanism to reduce operator effort. Small and compact, with ergonomically designed handles for ease of operation.

High quality materials combined with advanced design and manufacturing technology, produce a reliable tool with a guaranteed consistent, crimping operation.



ND1



TECHNICAL FEATURES

Crimping Range

Insulated and uninsulated end sleeves for conductors sizes 0,3 to 1,5 sqmm

Dimensions mm

Length	190
Width	72
Height	21
Weight g	470



ND2



TECHNICAL FEATURES

Crimping Range

Insulated and uninsulated end sleeves for conductors sizes 1 to 6 sqmm

Dimensions mm

Length	190
Width	72
Height	21
Weight g	470



ND3



TECHNICAL FEATURES

Crimping Range

Insulated and uninsulated end sleeves for conductors sizes 6 to 16 sqmm

Dimensions mm

Length	190
Width	72
Height	21
Weight g	470



ND4



TECHNICAL FEATURES

Crimping Range

Insulated and uninsulated end sleeves for conductors sizes 0,5 to 4 sqmm

Dimensions mm

Length	190
Width	72
Height	21
Weight g	470

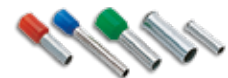

Package Dimensions mm

195 x 76 x 20

MECHANICAL TOOLS ZKE RANGE

for insulated and uninsulated end sleeves

ZKE



TECHNICAL FEATURES

Crimping Range	Single aperture, ratchet controlled tool for crimping end sleeves, 0,08 to 10 sqmm side insertion
Dimensions mm	
Length	180
Width	78
Height	20
Weight g	404



TECHNICAL FEATURES

Crimping Range	Single aperture, ratchet controlled tool for crimping end sleeves, 0,08 to 16 sqmm side insertion
Dimensions mm	
Length	178
Width	74
Height	30
Weight g	422



TECHNICAL FEATURES

Crimping Range	Tool for crimping end sleeves 0,5 to 6 sqmm front insertion
Dimensions mm	
Length	200
Width	80
Height	20
Weight g	372



TECHNICAL FEATURES

Crimping Range	For end sleeves 0,5 to 16 sqmm
Dimensions mm	
Length	190
Width	62
Height	11
Weight g	240



ZKE610



ZKE616



ZKE6-F



ZKE2

HP4-R

MECHANICAL TOOLS HP4 RANGE

for insulated terminals and connectors



Professional manual mechanical tool with ratchet mechanism that prevents the handles from opening again before reaching the ratchet. Equipped with a positioning device to reduce the operator's effort and facilitate proper crimping of the conductor.

According to the different thicknesses of the conductor insulation, the crimping on the insulation can be carried out by adjusting the jaws through three different settings: 1) strong, 2) medium, 3) light. The tool is particularly easy to use thanks to its shape and handle coating.

TECHNICAL FEATURES

Crimping Range	PVC, PC and PA6.6 insulated terminals and connectors for conductor sizes 0,25 to 1,5 sqmm
Dimensions mm	
Length	265
Width	80
Height	24
Weight g	500
Package Dimensions	330 x 110 x 50 mm

At the end of the crimping the outer surface of the conductor is automatically stamped with the following crimping code: one point for red conductor sizes from 0.25 to 1.5 mm²

Construction features:

- Special treated and externally protected steel body, ratchet and handles.
- Handle coating in soft red PVC plastic.



HP4-B

MECHANICAL TOOLS HP4 RANGE

for insulated terminals and connectors



Professional manual mechanical tool with ratchet mechanism that prevents the handles from opening again before reaching the ratchet. Equipped with a positioning device to reduce the operator's effort and facilitate proper crimping of the conductor.

According to the different thicknesses of the conductor insulation, the crimping on the insulation can be carried out by adjusting the jaws through three different settings: 1) strong, 2) medium, 3) light. The tool is particularly easy to use thanks to its shape and handle coating.

TECHNICAL FEATURES

Crimping Range	PVC, PC and PA6.6 insulated terminals and connectors for conductor sizes 1,5 to 2,5 sqmm
Dimensions mm	
Length	265
Width	80
Height	24
Weight g	500
Package Dimensions	330 x 110 x 50 mm

At the end of the crimping the outer surface of the conductor is automatically stamped with the following crimping code: two points for blue conductor sizes from 1.5 to 2.5 mm²

Construction features:

- Special treated and externally protected steel body, ratchet and handles.
- Handle coating in soft blue PVC plastic.



MECHANICAL TOOLS HP4 RANGE

for insulated terminals and connectors

HP4-G



TECHNICAL FEATURES

Crimping Range	PVC, PC and PA6.6 insulated terminals and connectors for conductor sizes 4 to 6 sqmm
Dimensions mm	
Length	320
Width	105
Height	25
Weight g	810
Package Dimensions	330 x 110 x 50 mm

Professional manual mechanical tool with ratchet mechanism that prevents the handles from opening again before reaching the ratchet. Equipped with a positioning device to reduce the operator's effort and facilitate proper crimping of the conductor.

According to the different thicknesses of the conductor insulation, the crimping on the insulation can be carried out by adjusting the jaws through three different settings: 1) strong, 2) medium, 3) light. The tool is particularly easy to use thanks to its shape and handle coating.



At the end of the crimping the outer surface of the conductor is automatically stamped with the following crimping code: three points for yellow conductor from 4 to 6 sqmm

Construction features:

- Special treated and externally protected steel body, ratchet and handles.
- Handle coating in soft yellow PVC plastic.

MECHANICAL TOOLS HP4 RANGE

for sleeve connectors

HP4-C10



TECHNICAL FEATURES

Crimping Range	For sleeve connectors type C6-C6 and C10-C10
Dimensions mm	
Length	325
Width	105
Height	21
Weight g	730
Package Dimensions	330 x 110 x 50 mm



Professional manual mechanical tool with ratchet mechanism that prevents the handles from opening again before reaching the ratchet. The tool is particularly easy to use thanks to its shape and handle coating.

Construction features:

- Special treated and externally protected steel body, ratchet and handles.
- Handle coating in soft yellow PVC plastic.

HWE1

MECHANICAL TOOL HWE1

with interchangeable dies

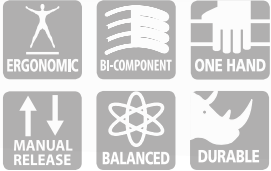

A robust and reliable tool designed to optimise the installers time and effort.

A single tool body with a range of interchangeable dies allows a quick and simple transfer from one cable/connector combination to another, across a range of applications.

TECHNICAL FEATURES:

- Automatic opening of handles following completion of the crimping operation
- Dull Nickel finish
- Anti-slip handle grips

TECHNICAL FEATURES

Dimensions mm

Length	240
Width	79
Height	32,5
Weight g	590



KIT-HWE1

- comprising:
- HWE1 Manual mechanical tool
 - WF16 die
 - IT6 die
 - all contained in a sturdy plastic case with extra compartments for interchangeable dies



INTERCHANGEABLE DIES INCLUDED IN THE KIT

INSULATED AND UNINSULATED END SLEEVES

WF16

Size 0,5 ÷ 16 sqmm

INSULATED CONNECTORS RED, BLUE AND YELLOW

IT6

Size 0,5 ÷ 6 sqmm

INTERCHANGEABLE DIES TO ORDER SEPARATELY

PHOTOVOLTAIC CONNECTORS (MULTI-CONTACT)

MC3

Size 4 ÷ 6 sqmm

MC4

Size 4 ÷ 6 sqmm



INSULATED AND UNINSULATED END SLEEVES

WF6

Size 0,5 ÷ 6 sqmm

WF35

Size 16 ÷ 35 sqmm

UNINSULATED CABLE LUGS

NIT10

Size 0,5 ÷ 10 sqmm

OPEN BARREL BRASS CONNECTORS

OB2.5P

Size 0,5 and 2,5 sqmm

SUB-D075

Size 0,05 and 0,75 sqmm

SUB-D050

Size 0,08 and 0,5 sqmm

COAXIAL CONNECTORS

C59

RG58, RG59, RG62

MLRJ1

MECHANICAL TOOL MLRJ1

MARKETline range



TECHNICAL FEATURES

Crimping Range

For crimping plugs RJ 11; RJ 12; RJ 14; RJ 22; RJ 45.
With cutting and wire-stripping blades

Dimensions mm

Length	211
Width	75
Height	23
Weight g	526



MECHANICAL TOOL IDT

with modular interchangeable dies

Dies for photovoltaic connectors



4300-3541
Tyco Solarlok

4300-3539
MC4 Multi Contact

4300-3540
MC3 Multi Contact

See page 138 for HB11 cable stripper



TECHNICAL FEATURES

Dimensions mm

Length	234
Width	64
Height	24
Weight g	460

INTERCHANGEABLE DIES TO ORDER SEPARATELY

INSULATED CONNECTORS RED, BLUE, YELLOW and GREEN

4300-3129 Size 0,5 ÷ 2,5 mm ² (Red - Blue)	4300-3128 Size 4 ÷ 6 mm ² (Yellow) Size 0,1 ÷ 0,4 mm ² (Green)
--	---

CONNECTORS WITH HEAT SHRINKABLE INSULATION

4300-3258 Size 0,5 ÷ 2,5 mm ² (Red - Blue)	4300-3262 Size 4 ÷ 6 mm ² (Yellow) Size 0,32 ÷ 0,75 mm ² (Green)
--	---

UNINSULATED CONNECTORS

4300-3137 Size 0,75 ÷ 2,5 mm ²	4300-3241 Size 4 ÷ 10 mm ²
---	---

CONTACTS FOR MULTI POLAR CONNECTORS (eg. ILME, HTS, CONTACT)

4300-3147 Size 0,14 ÷ 4 mm ²	4300-3148 Size 6 ÷ 10 mm ²
---	---

INSULATED AND UNINSULATED END SLEEVES

4300-3127 Size 0,25 ÷ 10 mm ²	4300-3153 Size 16 ÷ 25 mm ²	4300-3154 Size 35 ÷ 50 mm ²
--	--	--

OPEN BARREL CONNECTORS

4300-3146 Size 0,5 ÷ 6 mm ²
--

BNC/TNC CONNECTORS FOR COAXIAL CABLES

4300-3136 RG 58, 59, 62, 71	4300-3140 RG 174, 179
---------------------------------------	---------------------------------

TV - SATELLITE RECEIVER CONNECTORS

4300-3138 RG 6, 59

PHONE CONNECTORS

4300-3144 RJ 45 (LARGE)	4300-3132 RJ 11 (SMALL)
-----------------------------------	-----------------------------------

PHOTOVOLTAIC CONNECTORS (MULTI-CONTACT)

4300-3540 MC3 Size 2,5 - 4/6 mm ²	4300-3539 MC4 Size 2,5/4/6 mm ²	4300-3541 Tyco Solarlok Size 2,5/4/6 mm ²
---	---	---



A robust and reliable tool designed to optimise the installers time and effort.

A single tool body with a range of interchangeable dies allows a quick and simple transfer from one cable/connector combination to another, across a wide range of applications. Modular dies may be inserted/extracted without using any tools and are connected in pairs for speed and convenience.

To assist correct die selection, the type of connector is illustrated on each die.

Each die also carries an illustration of the steps in each crimping process, to assist in achieving the best result.



VALSTAR R3 IDT

To order separately - sturdy plastic case designed to store an IDT tool and up to 10 modular dies.

Modular die storage housings are easily combined for convenient transportation



Modular die pack



TN70SE TN70

MECHANICAL TOOLS TN RANGE

for uninsulated terminals and connectors



Professional manual mechanical tool suitable for crimping A-M Cu lugs and non-insulated L-M and L-P connectors.
Heat treated steel crimp jaws.
Easily adjustable die positioning by knurled screw and reference vernier scale.
Handles made from anti-slip plastic with hilt.



TECHNICAL FEATURES

Crimping Range	*Uninsulated terminals and connectors for conductor sizes 6 R/F to 70 R/F sqmm
Dimensions mm	
Length	450
Width	127
Height	47
Weight kg	2

*R= Rigid conductor F= Flexible conductor

TN70SE: vernier scale with section of conductors
TN70: vernier scale with connector sizes

TNN70

MECHANICAL TOOLS TN RANGE

for insulated terminals and connectors



Professional manual mechanical tool suitable for the crimping of wire terminals and PA 6.6 insulated connectors.
Heat treated steel crimp jaws.
Easily adjustable die positioning by knurled screw and reference vernier scale.
Handles made from anti-slip plastic with hilt.



TECHNICAL FEATURES

Crimping Range	*Polyamide PA6.6 insulated terminals and connectors for conductor sizes 10 F to 70 F sqmm
Dimensions mm	
Length	450
Width	127
Height	47
Weight kg	2

*F= Flexible conductor

MECHANICAL TOOLS TN RANGE

for uninsulated terminals and connectors

TN120SE TN120S



TECHNICAL FEATURES

Crimping Range	*Uninsulated terminals and connectors for conductor sizes 10 R/F to 120 R/150 F sqmm	
Dimensions mm		
Length	700	
Width	170	
Height	47	
Weight kg	3	

*R= Rigid conductor F= Flexible conductor



Professional manual mechanical tool suitable for crimping A-M Cu lugs and non-insulated L-M and L-P connectors.

Heat treated steel crimp jaws. Easily adjustable die positioning by knurled screw and reference vernier scale.

Handles made from anti-slip plastic with hilt.

TN120SE: vernier scale with section of conductors

TN120S: vernier scale with connector sizes

MECHANICAL TOOLS TN RANGE

for insulated terminals and connectors

TNN120

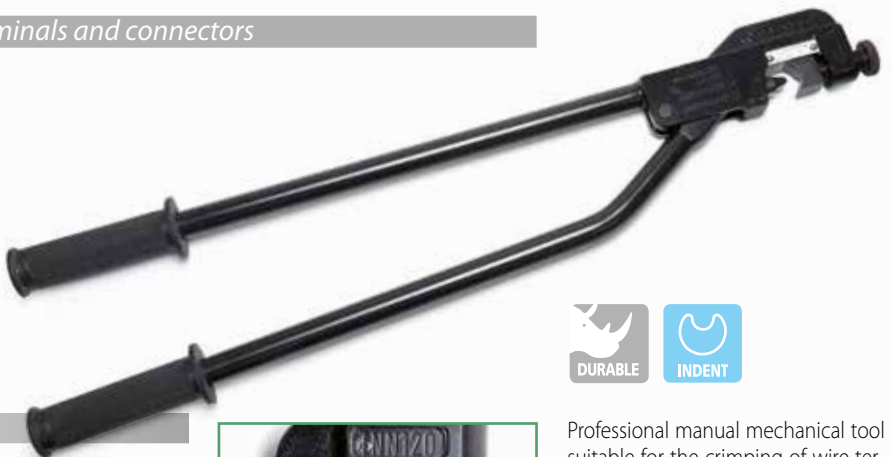

TECHNICAL FEATURES

Crimping Range	*Polyamide PA6.6 insulated terminals and connectors for conductor sizes 10 F to 120 F sqmm	
Dimensions mm		
Length	700	
Width	170	
Height	47	
Weight kg	3	

*F= Flexible conductor



Professional manual mechanical tool suitable for the crimping of wire terminals and PA 6.6 insulated connectors.

Heat treated steel crimp jaws. Easily adjustable die positioning by knurled screw and reference vernier scale.

Handles made from anti-slip plastic with hilt.

TND6-70

MECHANICAL TOOLS TND RANGE

for uninsulated terminals and connectors according to DIN 46235 and DIN 46267 T.1



Mechanical tools equipped with rotating dies with hexagonal imprint compliant with DIN 480863 suitable to crimp Copper lugs according to DIN 46235 and through connectors according to DIN 46267 T.1 (refer to page 44-45), particularly sturdy and easy to handle.



TECHNICAL FEATURES

Crimping Range

Uninsulated terminals and connectors according to DIN 46235 and DIN 46267 T.1 for conductor sizes 6 to 70 sqmm

Dimensions mm

Length	515
Width	132
Height	46
Weight kg	2



TND10-120

MECHANICAL TOOLS TND RANGE

for uninsulated terminals and connectors according to DIN 46235 and DIN 46267 T.1



Mechanical tools equipped with rotating dies with hexagonal imprint compliant with DIN 480863 suitable to crimp Copper lugs according to DIN 46235 and through connectors according to DIN 46267 T.1 (refer to page 44-45), particularly sturdy and easy to handle.



TECHNICAL FEATURES

Crimping Range

Uninsulated terminals and connectors according to DIN 46235 and DIN 46267 T.1 for conductor sizes 10 to 120 mm²

Dimensions mm

Length	665
Width	162
Height	52
Weight kg	3,7



CABLE CUTTERS KT RANGE

for cutting cables Cu and Al

KT

TECHNICAL FEATURES

Cutting Capacity	Rigid	Multi-Cond.	Flex
Section Cond. mm ²	Cu 16 Al 35	Cu 50 Al 50	Cu 70
Dimensions mm			
Length	170		
Width	45		
Weight g	210		

KT1



TECHNICAL FEATURES

Cutting Capacity	Rigid	Multi-Cond.	Flex
Section Cond. mm ²	Cu 16 Al 50	Cu 50 Al 70	Cu 95
Dimensions mm			
Length	210		
Width	47		
Weight g	294		

KT2



TECHNICAL FEATURES

Cutting Capacity	for cutting cables Cu and Al up to max section 25 sqmm
Dimensions mm	
Length	170
Width	52
Weight g	108

KT5



TECHNICAL FEATURES

Cutting Capacity	For cutting cables Cu and Al Ø max 34 mm
Dimensions mm	
Length	260
Weight g	600

KT3N



TECHNICAL FEATURES

Cutting Capacity	For cutting cables Cu and Al Ø max 62 mm
Dimensions mm	
Length	297
Weight g	800

KT4N



TECHNICAL FEATURES

Cutting Capacity	For cutting cables Cu and Al Ø max 18 mm
Dimensions mm	
Length	600
Width	140
Weight kg	1,5

5116660250



TECHNICAL FEATURES

Cutting Capacity	For cutting cables Cu and Al Ø max 25,4 mm
Dimensions mm	
Length	800
Width	160
Weight kg	3,0

5116660500

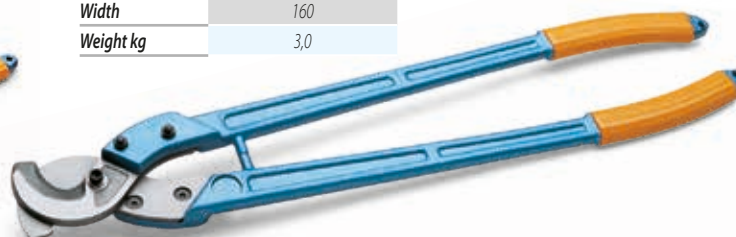

HB6

WIRE STRIPPERS HB RANGE

for insulated cables



Wire strippers, including stripping die for PVC insulated cables 0,02 to 10 sqmm

Interchangeable stripping dies available upon request:



4320-0866, rounded blades
suitable for:
PVC from 4 to 16 sqmm



4320-0864, flat blade
suitable for:
PVC from 0,02 to 10 sqmm



4320-0865, 'V' blades
suitable for:
PTFE from 0,1 to 4 sqmm

HB11



For photovoltaics insulated cables 2,5 to 6 sqmm
stripping length 8,5 mm



SC1

PROFESSIONAL SCISSORS SC RANGE

for flexible conductors Cu-Al



Electricians scissors with high tensile steel blades allowing for excellent strength and performance. Specially micro-serrated blades for anti-slip purpose. Handles are made from dual component materials.

SC5X

Robust-A



Professional scissors with Special Steel frame, high hardness blades (58 HRC) and anti slide serrations. The moulded plastic handles combine a rigid structure with a softer material for finger comfort.
Cutting of flexible conductors up to 50 mm²



Supplied with carry case and swivel belt hook.

SC3X



Multi-purpose scissors with high hardness blades (56 HRC) and anti slide serrations. The moulded plastic handles combine a rigid structure with a softer material for finger comfort.
Cutting of flexible conductors up to 35 sqmm

SC6X

Agil-E



Only 86 g weight, the tapered blades and streamlined handles encourage agility and speed of operation. Handles have an integrated crimping system for end sleeves. high hardness blades (58 HRC) and anti slide serrations.
Cutting of flexible conductors up to 50 mm²



Supplied with carry case belt hook.

CABLE STRIPPING TOOLS HB RANGE

for external sleeves of Low/Medium Voltage cables



Universal cable stripping tool for external sleeves of Low/Medium Voltage cables \varnothing 12,7 to 63,5 mm and primary insulator in XLPE max \varnothing 38,1 mm



HB13UE

For vulcanised extruded semiconductor



The HB 12N kit includes:

- HB 12N cable stripping tool
- sturdy plastic case



HB12N cable stripping tool removes the semiconductor layer by being manually rotated around the cable while lateral advancement is achieved automatically. Safe and convenient, it can be used on cables with a semi-con diameter between 18 - 60 mm.

HB12N

- Sturdy frame in anodised Aluminium alloy and Steel.
- Special Steel blade with precise cutting depth regulation.
- Stripping operation can start at any point along the conductor.
- Bearing mounted rollers provide smooth cutting action.
- With "REVERSE" function, which allows the removal of semiconductor up to 7 mm thick from the sheath of the cable.
- Double speed for each direction.

HB2



Cable stripping tool for circular cables \varnothing 4,5 to 28,5 mm

HB10



Insulated knife has an interchangeable straight blade and plastic blade protector that folds into the handle. Ergonomic handle made of anti shock plastic material



HB9

Insulated knife, with curved blade and protective cover. Suitable for insulation and screen removal, equipped with blade guide to avoid damage to strands. Handle is made of a bi-component plastic material.



KTS1632

HAND TOOLS

for cutting and sealing flexible plastic conduit



Cuts and seals flexible plastic conduit in a single operation. Lightweight and easy to operate. Suitable for flexible conduits from Ø16 to Ø32 mm.



TECHNICAL FEATURES

Dimensions mm

Length	230
Width	58
Thickness	32
Weight kg	0,32

PC1

for cutting plastic pipe



Plastic pipe cutting tool
Cutting capacity: Ø 6 to Ø 42 mm.



Body: die-cast aluminium alloy
Blade material: hardened Carbon Steel

TECHNICAL FEATURES

Dimensions mm

Length	195
Width	96
Thickness	27
Weight kg	0,32

MT-FC48N

FRAME-TYPE HOLE PUNCHING TOOL

for cable trunking



Lightweight and easy to operate, designed for punching holes up to 47,2 mm diameter in the side wall of trunking without the need for pre drilling.

TECHNICAL FEATURES

Dimensions mm

Length	251,5
Width	224
Thickness	66
Weight kg	3,28

VAL-P30

Supplied in a robust plastic case.

Table denotes the punch/die set reference, for each hole size. Suitable for punching holes in mild steel, fibreglass or plastic material, up to 2 mm thick.

Hole Dimensions					Maximum thickness of mild steel (mm)	Type
Nominal						
Ø (mm)	Ø (inch)	Pg	ISO	Inch		
15,5	.610	Pg9	-	-	2	RD15.5SS-FC
16,2	.638	-	ISO-16	-		RD16.2SS-FC
17,5	.689	-	-	-		RD17.5SS-FC
18,8	.740	Pg11	-	-		RD18.8SS-FC
19,1	.752	-	-	-		RD19.1SS
20,5	.807	Pg 13,5	ISO-20	-		RD20.5SS
22,6	.890	Pg16	-	-		RD22.6SS
23,8	.937	-	-	5/8"		RD23.8SS
25,4	1.000	-	ISO-25	-		RD25.4SS
27,0	1.063	-	-	3/4"		RD27.0SS
28,5	1.122	Pg21	-	-		RD28.5SS
30,5	1.201	-	-	7/8"		RD30.5SS
31,8	1.252	-	-	-		RD31.8SS
32,5	1.279	-	ISO-32	-		RD32.5SS
34,6	1.362	-	-	-		RD34.6SS
37,2	1.464	Pg29	-	-		RD37.2SS
38,1	1.500	-	-	-		RD38.1SS
40,5	1.594	-	ISO-40	-		RD40.5SS-FC
41,3	1.626	-	-	-		RD41.3SS-FC
42,5	1.673	-	-	1 1/4"		RD42.5SS-FC
43,2	1.701	-	-	-		RD43.2SS-FC
44,5	1.752	-	-	-		RD44.5SS-FC
47,2	1.858	Pg36	-	-	RD47.2SS-FC	

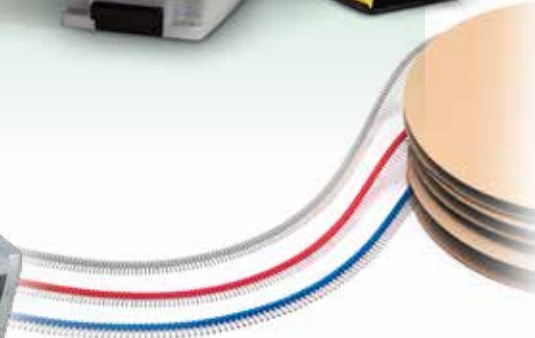

BENCH PRESS TOOLS

Pneumo-hydraulic with interchangeable dies



Pneumo-hydraulic, production bench press, controlled by a foot operated pedal, provides a consistent and reliable crimped connection. Extensive range of interchangeable dies available for crimping a wide variety of connectors.

NOTE: for applications not listed, please contact Cembre.



PNB-1 detail of the crimping zone with PU-1 guard.

TECHNICAL FEATURES

Nominal operating pressure	6 bar
Dimensions mm	
Width	180
Depth	320
Height	700
Weight kg (without dies)	23

INTERCHANGEABLE DIES (to be ordered separately)

Die Set	Guard*	Connector Type			Nominal Conductor Size sqmm			
PV-1	PU-1	Insulated Connectors	green	0,2÷0,5				
PR-1			red	0,25÷1,5				
PB-1			blue	1,5÷2,5				
PG-1			yellow	4÷6				
PH1-1	PH-1**	Through connectors PE HD insulated		0,5÷6				
		NL-M, NL-P connectors PA6.6 insulated		0,25÷6				
KE0.75-1	PK-1	End Sleeves	KE, PK...	0,3 - 0,5 - 0,75				
KE2.5-1				1 - 1,5 - 2,5				
KE10-1				4 - 6 - 10				
MTT16-50	ME-1			16				
MTT25-50				25				
N1-1	PU-1	A 03-M..	S 1.5-..	RN-..	0,25 - 1,5			
		A 06-M..	S 2.5-..	BN-..	1,5 - 2,5			
		A 1-M..	S 6-..	GN-..	4 - 6			
ME1-50	ME-1	Uninsulated Copper Lugs		A1-M..	4 - 6			
ME2-50				A2-M.. S10-M..	10			
ME3-50				A3-M..	16			
ME5-50				A5-M..	25			
ME7-50				A7-M..	35			
ME9-50				A9-M..				
ME10-50				A10-M..	50			
ME12-50				A12-M..				
MN2RF-50				MN RF-1	Polyamide Insulated Lugs		ANE2-M..	10
MN3RF-50							ANE3-M..	16
MN5RF-50	ANE5-M..	25						
MN7RF-50	ANE7-M..							
	ANE9-M..	35						

* Supplied as standard with the machine ** Supplied as standard with the die

BENCH PRESS TOOL

Pneumatic

TECHNICAL FEATURES

Nominal operating pressure	6±7 bar
Dimensions mm	
Width	130
Depth	370
Height	195
Weight kg	10,3



PNB-3P detail of the crimping zone.

BENCH PRESS RANGE

Type	Connector Type	Conductor Size sqmm
PNB-3P*	Insulated connectors red, blue and yellow	0,25÷6
PNB-3PD	Insulated terminals and butt connectors - frontal insertion	0,25÷6
PNB-3N1	Uninsulated terminals	0,25÷10
PNB-3N5	Uninsulated terminals	10÷16
PNB-3NN3	Polyamide insulated terminals	1,5÷10
PNB-3NN4	Polyamide insulated terminals	10÷16
PNB-3F/M	Bullet connectors	0,5÷2,5

* Will also crimp Polycarbonate fully-insulated terminals if fitted with PNB3F/M positioner, available as an optional accessory (Cod. 6240145)

Pneumatic bench press operated by foot pedal for crimping terminals and connectors 0,25 to 16 sqmm.

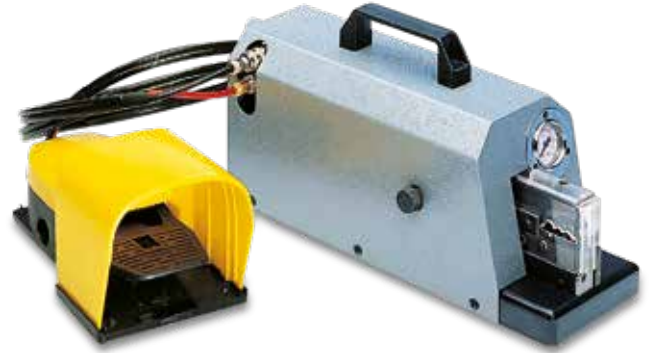

BENCH PRESS TOOL

Pneumatic with multi-aperture die

TECHNICAL FEATURES

Nominal operating pressure	6 bar
Dimensions mm	
Width	120
Depth	160
Height	300
Weight kg	6



PNB-4KE detail of the crimping zone.

MULTI DIES

Type	Connector Type	Conductor Size sqmm
PNB-4KE	End Sleeves type PK.. and type KE	0,3÷10

Pneumatic bench press, controlled by a foot operated pedal.

Supplied with a multi-aperture die suitable for crimping insulated and uninsulated end sleeves from 0,3 to 10 sqmm.

Compact and efficient. Easy to operate, producing a secure and reliable crimped connection.





Bench press type EPB-1NE, electro-pneumatically operated, is designed for stripping and crimping insulated end sleeves Cembre type PKC, PKD and PKE.

The basic configuration processes connectors of c.s.a 0,5/0,75/1,0 and 1,5 mm² with a sleeve lengths of 6, 8, 10 and 12 mm.

Adapter kits are available:

KIT 2.5-EPB1N

for insulated end sleeves c.s.a 2,5 sqmm with a sleeve length of 8, 10 and 12 mm

KIT 4-EPB1N

for insulated end sleeves c.s.a 4,0 sqmm with a sleeve length of 10 mm
Stripping and crimping operations are carried out in quick succession. Adjustable loading speed of vibrating charger.

Quick and easy change of configuration for different connector sizes. Automatic adjustment of operating parameters to suit each configuration.

Modular structure and wear-free components guarantee excellent reliability.



Adapter Kit for insulated end sleeves c.s.a 2,5 sqmm
(KIT-2.5-EPB1N)
(KIT-4-EPB1N)



TECHNICAL FEATURES

Crimping Range	0,5-1,5 mm ² (basic configuration)
Dimensions mm	
Length	390
Width	240
Height	490
Weight kg	29
Power Supply	230 V/50 Hz (110 V/60 Hz)
Current	0,5 A
Length of crimp	6, 8, 10 and 12 mm
Geometry of crimp	Trapezoidal
Cycle time	2 s
Compressed Air supply	Min. 4 - Max 6 bar
Air consumption	1,2 l/cycle
Cycle controller	Electro-pneumatic, with microprocessor
Counter	Digital

PNEUMATIC CRIMPING TOOLS

Hand held - PNB series

PNB-6KE TECHNICAL FEATURES

Crimping Range	0,25 ÷ 2,5 sqmm / 24 ÷ 14AWG
Dimensions mm	
Length	190
Width Ø	44
Length with spiral hose	2 m
Weight g	450

PNB-7KE TECHNICAL FEATURES

Crimping Range	4 ÷ 10 sqmm / 12 ÷ 8AWG
Dimensions mm	
Length	190
Width Ø	44
Length with spiral hose	2 m
Weight g	450

PNB-6KE and PNB-7KE hand tools facilitate the rapid crimping of insulated end sleeves while avoiding the operator discomfort associated with ordinary manual tools.

Lightweight and easy to use, these tools are ideal for panel building applications and component assembly.

Both tools are designed to be maintenance-free and need no routine calibration. A 4-6 bar air supply is required for connection via the quick coupler fitted to the hose supplied with the tool.

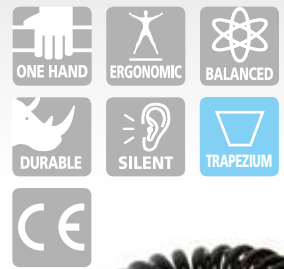

PNEUMATIC CRIMPING TOOLS

Bench mounted tools with foot pedal - PNB series

PNB-6KE-T TECHNICAL FEATURES

Crimping Range	0,25 ÷ 2,5 sqmm / 24 ÷ 14AWG
Dimensions mm	
Length	200
Width Ø	135
Height	75
Length with spiral hose	2 m
Weight g	1000

PNB-7KE-T TECHNICAL FEATURES

Crimping Range	4 ÷ 10 sqmm / 12 ÷ 8AWG
Dimensions mm	
Length	200
Width Ø	135
Height	75
Length with spiral hose	2 m
Weight g	1000

PNB-6KE-T and PNB-7KE-T have bench mounts with storage and are foot pedal operated to allow operators to have both hands free when assembling cable harnesses.

Both tools are designed to be maintenance-free and need no routine calibration.



A 4-6 bar air supply is required for connection via the quick coupler fitted to the hose supplied with the tool.

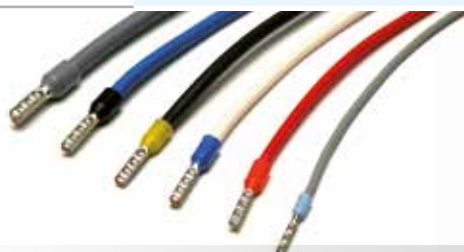

for Polycarbonate insulated chain connectors



Electro-pneumatic, production bench press, controlled by a foot operated pedal. Producing a consistent and reliable crimped connection. Interchangeable application heads available to suit the complete range of Polycarbonate insulated connectors.

See pages 12-13 and 20 for types and features of the insulated chain connectors and end sleeves.

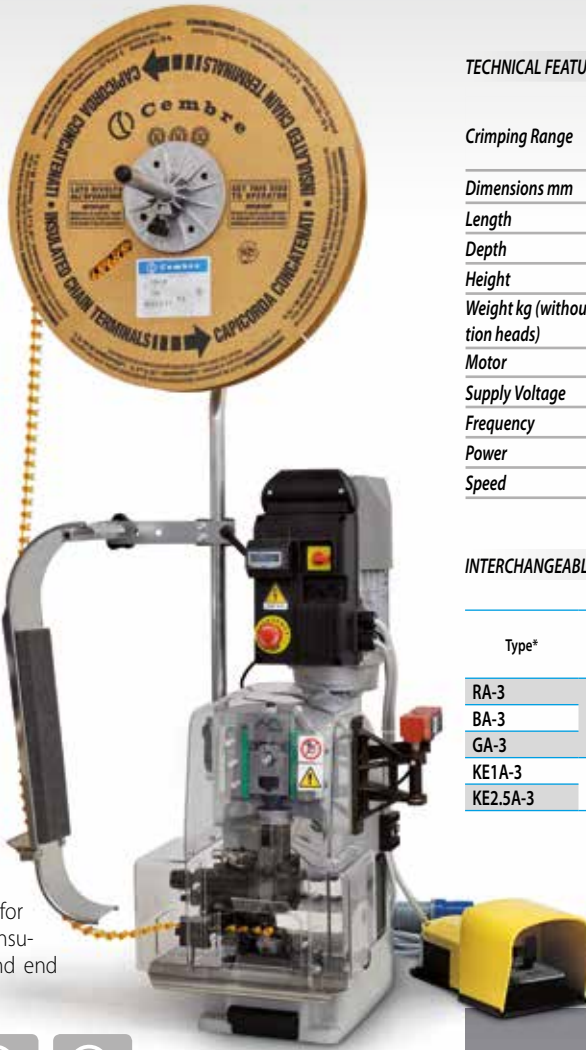

TECHNICAL FEATURES

Crimping Range	Polycarbonate insulated chain terminals 0,25 ÷ 6 mm ² and insulated chain end sleeves 0,5 ÷ 2,5 mm ²
Dimensions mm	
Length	180
Depth	250
Height	620
Weight kg (without application heads)	41
Motor	
Supply Voltage	220 V
Frequency	50 Hz
Power	0,55 kW/0,75 HP
Speed	2.800 g/1'

INTERCHANGEABLE APPLICATION HEADS, SIDE ENTRY WITH PNEUMATIC FEED

Type*	Connectors	Conductor Size sqmm
RA-3	Polycarbonate insulated chain terminals	0,25÷1,5
BA-3		1,5÷2,5
GA-3		4÷6
KE1A-3	Insulated chain end sleeves	0,5÷1
KE2.5A-3		1÷2,5

* order as required



Conforms to DIN Standard 46 228/4





















HYDRAULIC CRIMPING TOOLS AND CUTTERS

symbol description

hydraulic crimping tools and cutters

	Crimping force kN		Provided with a maximum pressure valve that allows to check the correct execution of the compressions or the limit switch control of the blades
	Double speed action: a rapid approach speed and a slower more powerful speed for crimping or cutting		Manual pressure release button
	Openable compression head, ideal for derivations from running conductors		Ergonomically designed with a sculptured body for operator comfort
	Openable cutting head, ideal for cutting running cables		Lightweight and balanced tool for greater control
	Tool with a large 42 mm jaw opening, for easier introduction/removal of large size compression terminations and joints		Dual-compound plastic handles. Greater safety and comfort in handling, thanks to the rubber inserts
	Blades manufactured from high strength special Steel, heat treated to ensure a long service life		Durable moulded body offering high resistance to wear and damage in all operating conditions
	Max cutting diameter		CE marking
	Max hole punching diameter		
	The head can rotate to enable the operator to work in the most comfortable position		
	Can be operated with one hand		

symbol description

hydraulic crimping tools and cutters



Hexagonal crimp



Radial crimp



Indent crimp



Deep indent crimp



"W" crimp



Oval crimp



Trapezium crimp



Circular crimp



Max operating pressure



Contains isolated oil



Hydraulic units provide protection against short circuit when accidentally cutting live L.V. / M.V. cables with nominal voltage up to 60 kV



HT45-E

HYDRAULIC CRIMPING TOOL

general features

MAIN APPLICATIONS - max section sqmm

Section sqmm	0,25-1,5	1,5-2,5	4-6	10	16	25	35	50	70	95	120	150	185	240	300	400	500	630	800	1000	
L.V. lugs and splices																					
"C" sleeve Connectors																					

These tools are supplied without dies. For die selection, please refer to chart on pages 248 to 262

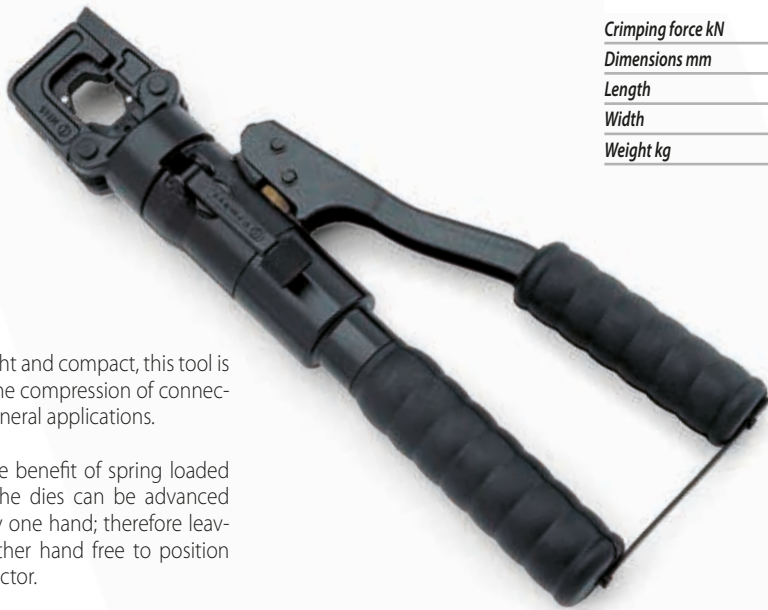

Lightweight and compact, this tool is ideal for the compression of connectors for general applications.

Having the benefit of spring loaded handles, the dies can be advanced using only one hand; therefore leaving the other hand free to position the connector.

For ease of operation and comfort of the operator, the tool head can be fully rotated through 180 degrees.

The built-in safety valve will by-pass the oil supply when the maximum pressure is reached, and a pressure releasing system can easily be operated at any stage of the compression.



The operator can advance the dies using only one hand, leaving the other hand free to position the connector.

TECHNICAL FEATURES

Crimping force kN	50
Dimensions mm	
Length	346
Width	130
Weight kg	2,0

STORAGE

Type	VAL-P1*
Dimensions mm L x W x H	445 x 290 x 95
Weight kg	1,2
Supplied with the tool	✓
Purchase separately	-

*Suitable for storage of the tool and 20 sets of dies



Openable head, ideal for derivations from running conductors

180° rotatable head, to work in the most comfortable position

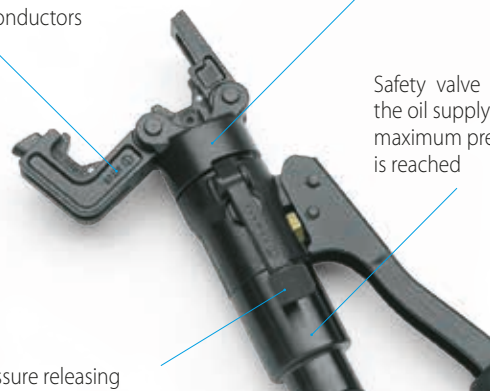

Safety valve bypassing the oil supply when the maximum pressure is reached

Pressure releasing system, that can be operated at any stage

HYDRAULIC CRIMPING TOOL

HT51

general features

MAIN APPLICATIONS - max section sqmm

Section sqmm	0.25-1.5	1.5-2.5	4-6	10	16	25	35	50	70	95	120	150	185	200	240	300	400	500	630	800	1000	
L.V. lugs and splices																						
Insulated terminals																						
End sleeves																						
"C" sleeve Connectors																						
H.V. lugs and splices																						

These tools are supplied without dies. For die selection, please refer to chart on pages 248 to 262

STORAGE

Type	VAL-P1*
Dimensions mm L x W x H	445 x 290 x 95
Weight kg	1,2
Supplied with the tool	✓
Purchase separately	-

* Suitable for storage of the tool and 20 sets of dies

TECHNICAL FEATURES

Crimping force kN	50
Dimensions mm	
Length	380
Width	130
Weight kg	2,7

For ease of operation and comfort of the operator, the tool head can be fully rotated through 180 degrees. The built-in safety valve will by-pass the oil supply when the maximum pressure is reached, and a pressure release system can easily be operated at any stage of the compression.

New design two speed hydraulic tool, lightweight and compact, this tool is ideal for working in confined spaces.

Having the benefit of spring loaded handles, the dies can be advanced using only one hand; therefore leaving the other hand free to position the connector.



HT51-KV version also available for Power Supply Companies



HT51 COMPRESSION KIT

general features

KIT-HT51-1

Kit includes:

HT51 Hydraulic tool	
VAL-P1 plastic carrying case	
8 die sets:	
ME5-50	Hexagonal crimp for low voltage terminals and through connectors from 25 to 185 mm ² A-M family
ME7-50	
ME10-50	
ME14-50	
ME19-50	
ME24-50	
ME30-50	
ME37-50	

KIT-HT51-2

Kit includes:

HT51 Hydraulic tool		
VAL-P1 plastic carrying case		
6 die sets:		
Nest	Indent	Indent crimp for low voltage general purpose terminals and through connectors from 25 to 120 mm ²
MA5-50	PA5-50	
MA7-50	PA7-50	
MA10-50	PA10-50	
MA14-50	PA14-50	
MA19-50	PA19-50	
MA24-50	PA24-50	

KIT-HT51-MK

Kit includes:

HT51 Hydraulic tool	
VAL-P1 plastic carrying case	
9 die sets:	
MK8-50	Hexagonal crimp for low voltage terminals and through connectors from 16 to 185 mm ² DIN 46235 family
MK10-50	
MK12-50	
MK14-50	
MK16-50	
MK18-50	
MK20-50	
MK22-50	
MK25-50	

KIT-HT51-1 KIT-HT51-2 KIT-HT51-MK



RH50

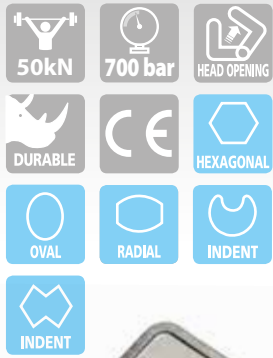

Hydraulic presshead complete with quick automatic coupler for connection to a hydraulic pump with a working pressure of 700 bar max, (see page 218-224). RH50 is suitable for installing the same range of connectors as HT51.

HYDRAULIC PRESSHEAD

general features

MAIN APPLICATIONS - max section sqmm

Section sqmm	0.25-1.5	1.5-2.5	4-6	10	16	25	35	50	70	95	120	150	185	200	240	300	400	500	630	800	1000	
L.V. lugs and splices																						
Insulated terminals																						
End sleeves																						
"C" sleeve Connectors																						
H.V. lugs and splices																						

These tools are supplied without dies. For die selection, please refer to chart on pages 248 to 262

TECHNICAL FEATURES

Crimping force kN	50
Max operating pressure bar	700
Dimensions mm	
Length	195
Width	75
Weight kg	1,6

STORAGE

Type	VAL-P1*
Dimensions mm L x W x H	445 x 290 x 95
Weight kg	1,2
Supplied with the tool	✓
Purchase separately	-

* Suitable for storage of the head and 20 sets of dies



STORAGE

Type	CVB-007
Dimensions mm L x W	350 x 105
Weight kg	0,13
Supplied with the tool	-
Purchase separately	✓



RHM50



Hydraulic presshead complete with quick automatic coupler for connection to hydraulic pump with working pressure of 700 bar max, (see page 218-224). RHM50 is suitable for installing the same range of connectors as RH50.

HYDRAULIC PRESSHEAD

general features

MAIN APPLICATIONS - max section sqmm

Section sqmm	0.25-1.5	1.5-2.5	4-6	10	16	25	35	50	70	95	120	150	185	240	300	400	500	630	800	1000	
L.V. lugs and splices																					
Insulated terminals																					
End sleeves																					

These tools are supplied without dies. For die selection, please refer to chart on pages 248 to 262

Particularly suitable for high volume bench crimping.

TECHNICAL FEATURES

Crimping force kN	50
Max operating pressure bar	700
Dimensions mm	
Length	210
Width	70
Weight kg	1,6

STORAGE

Type	VAL-P1*
Dimensions mm L x W x H	445 x 290 x 95
Weight kg	1,2
Supplied with the tool	✓
Purchase separately	-

* Suitable for storage of the head and 20 sets of dies



STORAGE

Type	CVB-007
Dimensions mm L x W	350 x 105
Weight kg	0,13
Supplied with the tool	-
Purchase separately	✓



HYDRAULIC CRIMPING TOOL

general features

MAIN APPLICATIONS - max section sqmm

Section sqmm	0,25÷1,5	1,5÷2,5	4÷6	10	16	25	35	50	70	95	100	120	150	185	200	240	300	400	500	630	800	1000	
L.V. lugs and splices																							
Insulated terminals																							
"C" sleeve Connectors																							
H.V. lugs and splices																							

These tools are supplied without dies. For die selection, please refer to chart on pages 248 to 262

STORAGE

Type	VAL-P7*
Dimensions mm L x W x H	727 x 202 x 115
Weight kg	1,3
Supplied with the tool	✓
Purchase separately	-

* Suitable for storage of the tool and dies.
The dies can be stored in the canvas bag type CVB-013.

TECHNICAL FEATURES

Crimping force kN	60
Dimensions mm	
Length	489
Width	141
Weight kg	4,0

The HT61 is a two speed hydraulic hand compression tool developing a crimping force of 60 kN, suitable for installing crimp type electrical connectors on copper cables up to 240 sqmm.

Die set common to 50 kN Cembre tools (e.g. HT51, RH50) can be used in this tool only with spring code 6522051, purchased separately. The built-in safety valve will by-pass the oil supply when the maximum pressure of 600 bar is reached and a pressure releasing system can be easily operated at any stage of the compression.

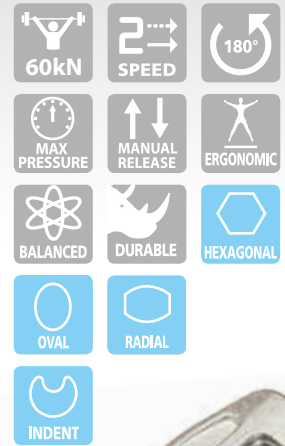

For ease of operation and comfort of the operator the tool head can be fully rotated through 180° degrees. In addition to a comprehensive range of dies, is also possible to use dies from other manufacturers type Gr.1.

HYDRAULIC PRESSHEAD

general features

MAIN APPLICATIONS - max section sqmm

Section sqmm	0,25÷1,5	1,5÷2,5	4÷6	10	16	25	35	50	70	95	100	120	150	185	200	240	300	400	500	630	800	1000	
L.V. lugs and splices																							
Insulated terminals																							
"C" sleeve Connectors																							
H.V. lugs and splices																							

These tools are supplied without dies. For die selection, please refer to chart on pages 248 to 262

TECHNICAL FEATURES

Crimping force kN	60
Max operating pressure bar	700
Dimensions mm	
Length	245
Width	90,5
Weight kg	2,75

STORAGE

Type	VAL-RH60*
Dimensions mm L x W x H	430 x 200 x 70
Weight kg	2,2
Supplied with the tool	✓
Purchase separately	-

* Suitable for storage of the head and 14 sets of dies

STORAGE

Type	CVB-007
Dimensions mm L x W	350 x 105
Weight kg	0,13
Supplied with the tool	-
Purchase separately	✓

Hydraulic presshead complete with quick automatic coupler for connection to a hydraulic pump with a working pressure of 700 bar max, (see page 218-224). RH61 is suitable for installing the same range of connectors as HT61.

In addition to a comprehensive range of dies, is also possible to use dies from other manufacturers type Gr.1.



HT81-U

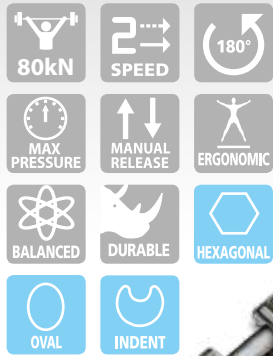

This lightweight and self contained tool, features a patented closure and release mechanism for the die locking pin. A wide range of connectors can be crimped with a small number of die sets due to their unique, double groove styling. Dies for cutting Copper, Aluminum, Aldrey and Aluminum-steel, are also available (see table below). The tool features a double speed action: a fast advancing speed for rapid approach of the dies to the connector and a slower more powerful speed for crimping.

For ease of operation and comfort of the operator the tool head can be fully rotated through 180 degrees. The built-in safety valve will by-pass the oil supply when the maximum pressure is reached, and a pressure releasing system can easily be operated at any stage of the compression.



HYDRAULIC CRIMPING TOOL

general features

MAIN APPLICATIONS - max section sqmm

Section sqmm	0.25-1.5	1.5-2.5	4-6	10	16	25	35	50	70	95	100	120	150	185	200	240	300	400	500	630	800	1000	
L.V. lugs and splices																							
"C" sleeve Connectors																							
H.V. lugs and splices																							

These tools are supplied without dies. For die selection, please refer to chart on pages 248 to 262

TECHNICAL FEATURES

Crimping force kN	80
Dimensions mm	
Length	485
Width	141
Weight kg	3,4

STORAGE

Type	VAL-P3*
Dimensions mm L x W x H	620 x 380 x 135
Weight kg	2,5
Supplied with the tool	✓
Purchase separately	-

*Suitable for storage of the tool and three VAL-75

STORAGE

Type	VAL-75*
Dimensions mm L x W x H	270 x 80 x 30
Weight kg	0,15
Supplied with the tool	-
Purchase separately	✓

*Suitable for storing five sets of dies



RHU81



Hydraulic presshead complete with quick automatic coupler for connection to a hydraulic pump with a working pressure of 700 bar max, (see page 218-224). This lightweight and self contained head, features a patented closure and release mechanism for the die locking pin.

The head is easy to use and is ideally suited for crimping in confined spaces. RHU81 is suitable for installing the same range of connectors as HT 81-U.

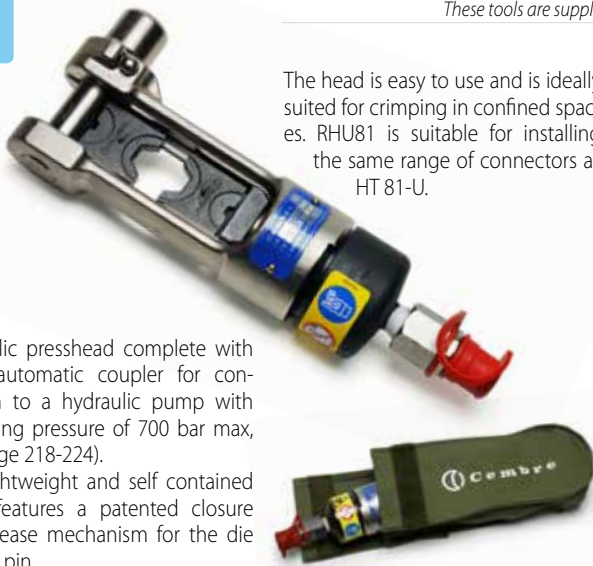

HYDRAULIC PRESSHEAD

general features

MAIN APPLICATIONS - max section sqmm

Section sqmm	0.25-1.5	1.5-2.5	4-6	10	16	25	35	50	70	95	100	120	150	185	200	240	300	400	500	630	800	1000	
L.V. lugs and splices																							
"C" sleeve Connectors																							
H.V. lugs and splices																							

These tools are supplied without dies. For die selection, please refer to chart on pages 248 to 262

TECHNICAL FEATURES

Crimping force kN	80
Max operating pressure bar	700
Dimensions mm	
Length	235
Width	91
Weight kg	1,9

STORAGE

Type	CVB-007
Dimensions mm L x W	350 x 105
Weight kg	0,13
Supplied with the tool	✓
Purchase separately	-

HT 81-U and RHU 81 ACCESSORIES FOR CUTTING CONDUCTORS

Die Type	Cutting Capacity	Conductor Type	
		Ø 16 mm	Cu, Alu, Aldrey and Alu-Steel
MB2-80U	This die is suitable to cut steel conductors (R ≤ 160 daN/mm ²) having the most common strandings, i.e.:	19 x 1,2 = Ø est. 6,0 mm	7 x 3,0 = Ø est. 9,0 mm
		19 x 2,1 = Ø est. 10,5 mm	19 x 2,3 = Ø est. 11,5 mm
MB3-80U	Suitable to cut aluminium strands of 150 mm ² aluminium-steel conductors, without damage to the steel core.		

HYDRAULIC CRIMPING TOOL

HT120

general features

MAIN APPLICATIONS - max section sqmm

Section sqmm	0.25-1.5	1.5-2.5	4-6	10	16	25	35	50	70	95	120	150	185	200	240	300	400	500	630	800	1000	
L.V. lugs and splices																						
Insulated terminals																						
"C" sleeve Connectors																						
H.V. lugs																						
H.V. Splices*																						

*limited to the cable insulation diameter

These tools are supplied without dies. For die selection, please refer to chart on pages 248 to 262

- 120kN
- 2 SPEED
- 180°
- MAX PRESSURE
- MANUAL RELEASE
- ERGONOMIC
- BALANCED
- DURABLE
- HEXAGONAL
- OVAL
- RADIAL
- INDENT
- INDENT

STORAGE

Type	VAL-P3*
Dimensions mm L x W x H	620 x 380 x 135
Weight kg	2,5
Supplied with the tool	✓
Purchase separately	-

*Suitable for storage of the tool and 14 sets of dies

TECHNICAL FEATURES

Crimping force kN	120
Dimensions mm	
Length	488
Width	138
Jaw opening	25
Weight kg	5,7

This lightweight and self contained tool will accept the semi-circular slotted dies, common to most 130 kN tools.

It is particularly suitable for installing crimp type electrical connectors for overhead line applications.

The tool features a double speed action: a fast advancing speed for rapid approach of the dies to the connector and a slower more powerful speed for crimping.



For ease of operation and comfort of the operator the tool head can be fully rotated through 180 degrees. The built-in safety valve will by-pass the oil supply when the maximum pressure is reached, and a pressure release system can easily be operated at any stage of the compression.

HT 120-KV version also available for Power Supply Companies



HT 120 features a double speed action: a fast advancing speed for rapid approach of the dies to the connector and a slower more powerful speed for crimping.



Die release system, protected from accidental operation



Pressure release trigger, which can be operated at any stage of the compression.



HT131-C

HYDRAULIC CRIMPING TOOL

general features



MAIN APPLICATIONS - max section sqmm

Section sqmm	0.25-1.5	1.5-2.5	4-6	10	16	25	35	50	70	95	120	150	185	200	240	300	400	500	630	800	1000	
L.V. lugs and splices																						
Insulated terminals																						
"C" sleeve Connectors																						
H.V. lugs																						
H.V. Splices*																						

*limited to the cable insulation diameter

These tools are supplied without dies. For die selection, please refer to chart on pages 248 to 262

TECHNICAL FEATURES

Crimping force kN	130
Dimensions mm	
Length	473
Width	144
Jaw opening	25
Weight kg	5,5

STORAGE

Type	VAL-P3*
Dimensions mm L x W x H	620 x 380 x 135
Weight kg	2,5
Supplied with the tool	✓
Purchase separately	-

*Suitable for storage of the tool and 14 sets of dies



This new model, self contained, robust and sturdy, will accept all semi-circular slotted dies, common to most 130 kN tools. The tool features a double speed action: a fast advancing speed for rapid approach of the dies to the connector and a slower more powerful speed for crimping.

For ease of operation and comfort of the operator the tool head can be fully rotated through 180 degrees. The built-in safety valve will by-pass the oil supply when the maximum pressure is reached, and the pressure release system can easily be operated at any stage of compression.

HT131-C COMPRESSION KIT

general features



KIT-HT131-C-1 KIT-HT131-C-2 KIT-HT131-C-MK



KIT-HT131-C-1

Kit includes:

HT131-C Hydraulic tool

VAL-P3 plastic carrying case

7 die sets:

ME10-C	Hexagonal crimp for low voltage terminals and through connectors from 50 to 240 mm ² A-M family
ME14-C	
ME19-C	
ME24-C	
ME30-C	
ME37-C	
ME48-C	

KIT-131-C-MK

Kit includes:

HT131-C Hydraulic tool

VAL-P3 plastic carrying case

11 die sets:

MK6-C	Hexagonal crimp for low voltage terminals and through connectors from 10 to 240 mm ² DIN 46235 family
MK8-C	
MK10-C	
MK12-C	
MK14-C	
MK16-C	
MK18-C	
MK20-C	
MK22-C	
MK25-C	
MK28-C	

KIT-HT131-C-2

Kit includes:

HT131-C Hydraulic tool

VAL-P3 plastic carrying case

11 die sets:

Nest	Indentor	Indent crimp for low voltage general purpose terminals and through connectors from 10 to 240 mm ²
MA2-C	PA10-C	
MA3-C		
MA5-C		
MA7-C	PA24-C	
MA10-C		
MA14-C	PA48-C	
MA19-C		
MA24-C		
MA30-C		
MA37-C		
MA48-C		

RHC131



Hydraulic presshead complete with quick automatic coupler for connection to a hydraulic pump with a working pressure of 700 bar max, (see page 218-224). This new design with improved mechanical features, is suitable for installing the same range of connectors as HT 131-C.

HYDRAULIC PRESSHEAD

general features

MAIN APPLICATIONS - max section sqmm

Section sqmm	0.25-1.5	1.5-2.5	4-6	10	16	25	35	50	70	95	120	150	185	200	240	300	400	500	630	800	1000	
L.V. lugs and splices																						
Insulated terminals																						
"C" sleeve Connectors																						
H.V. lugs																						
H.V. Splices*																						

*limited to the cable insulation diameter

These tools are supplied without dies. For die selection, please refer to chart on pages 248 to 262

TECHNICAL FEATURES

Crimping force kN	130
Max operating pressure bar	700
Dimensions mm	
Length	232
Width	124
Jaw opening	25
Weight kg	3,8

STORAGE

Type	VAL-P26*
Dimensions mm L x W x H	445 x 290 x 115
Weight kg	1,2
Supplied with the tool	-
Purchase separately	✓

*Suitable for storage of the head and 14 sets of dies



RHM132



Hydraulic presshead complete with quick automatic coupler for connection to a hydraulic pump with a working pressure of 700 bar max, (see page 218-224).

HYDRAULIC PRESSHEAD

general features

MAIN APPLICATIONS - max section sqmm

Section sqmm	0.25-1.5	1.5-2.5	4-6	10	16	25	35	50	70	95	120	150	185	200	240	300	400	500	630	800	1000	
L.V. lugs																						
Insulated terminals																						
H.V. lugs																						

These tools are supplied without dies. For die selection, please refer to chart on pages 248 to 262

TECHNICAL FEATURES

Crimping force kN	130
Max operating pressure bar	700
Dimensions mm	
Length	216
Width	80
Weight kg	3,1

STORAGE

Type	VAL-P26*
Dimensions mm L x W x H	445 x 290 x 115
Weight kg	1,2
Supplied with the tool	-
Purchase separately	✓

*Suitable for storage of the head and 14 sets of dies



HYDRAULIC CRIMPING TOOL

general features

MAIN APPLICATIONS - max section sqmm

Section sqmm	0.25÷1.5	1.5÷2.5	4÷6	10	16	25	35	50	70	95	120	150	185	200	240	300	400	500	630	800	1000	
L.V. lugs and splices																						
Insulated terminals																						
"C" sleeve Connectors																						
H.V. lugs and splices																						

These tools are supplied without dies. For die selection, please refer to chart on pages 248 to 262

STORAGE

Type	VAL-P3*
Dimensions mm L x W x H	620 x 380 x 135
Weight kg	2,5
Supplied with the tool	✓
Purchase separately	-

*Suitable for storage of the tool and 14 sets of dies



TECHNICAL FEATURES

Crimping force kN	130
Dimensions mm	
Length	538
Width	144
Jaw opening	42
Weight kg	7,0

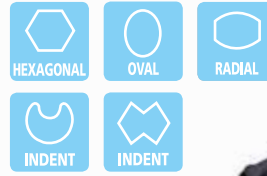

Hydraulic "C" head tool with a large 42 mm jaw opening, for easier introduction/removal of large size compression terminations and joints. The HT131LN-C will accept all semi-circular slotted dies, common to most 130 kN tools.



The tool features a double speed action: a fast advancing speed for rapid approach of the dies to the connector and a slower more powerful speed for crimping.

For ease of operation and comfort of the operator the tool head can be fully rotated through 180 degrees.

The built-in safety valve will by-pass the oil supply when the maximum pressure is reached, and the pressure release system can easily be operated at any stage of compression.

HYDRAULIC PRESSHEAD

general features

MAIN APPLICATIONS - max section sqmm

Section sqmm	0.25÷1.5	1.5÷2.5	4÷6	10	16	25	35	50	70	95	120	150	185	200	240	300	400	500	630	800	1000	
L.V. lugs and splices																						
Insulated terminals																						
"C" sleeve Connectors																						
H.V. lugs and splices																						

These tools are supplied without dies. For die selection, please refer to chart on pages 248 to 262

STORAGE

Type	VAL-P26*
Dimensions mm L x W x H	445 x 290 x 115
Weight kg	1,2
Supplied with the tool	-
Purchase separately	✓

*Suitable for storage of the head and 14 sets of dies

TECHNICAL FEATURES

Crimping force kN	130
Max operating pressure bar	700
Dimensions mm	
Length	298
Width	122
Jaw opening	42
Weight kg	5,4

Hydraulic head featuring a large 42 mm jaw opening; complete with quick automatic coupler for connection to a hydraulic pump with a working pressure of 700 bar max, (see page 218-224).

Is suitable for installing the same range of connectors as HT 131LN-C.

RHC131LN

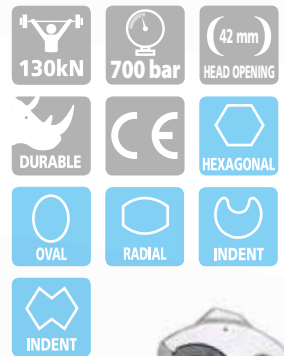

HT131-UC

HYDRAULIC CRIMPING TOOL



This robust and self contained tool will accept the accessories for performing the "Deep Stepped Indent" system of crimping on Aluminium cables. This tool will also accept the semi-circular slotted dies, common to most 130 kN tools. HT 131-UC performance features are the same as those of HT 131-C.

MAIN APPLICATIONS - max section sqmm

Section sqmm	0.25-1.5	1.5-2.5	4-6	10	16	25	35	50	70	95	120	150	185	200	240	300	400	500	630	800	1000	
L.V. lugs and splices																						
Insulated terminals																						
"C" sleeve Connectors																						
Alu lugs and splices																						
H.V. lugs and splices																						

These tools are supplied without dies. For die selection, please refer to chart on pages 248 to 262



STORAGE

Type	VAL-130*
Purchase separately	✓

*Suitable for the storage of accessories for crimping Aluminium connectors

TECHNICAL FEATURES

Crimping force kN	130
Dimensions mm	
Length	488
Width	149
Weight kg	5,4

STORAGE

Type	VAL-P3*
Dimensions mm L x W x H	620 x 380 x 135
Weight kg	2,5
Supplied with the tool	✓
Purchase separately	-

*Suitable for storage of the tool and 14 sets of dies



RHU131-C

HYDRAULIC PRESSHEAD



Hydraulic presshead complete with quick automatic coupler for connection to a hydraulic pump with a working pressure of 700 bar max, (see page 218-224). RHU131-C is suitable for installing the same range of connectors as HT 131-UC.

MAIN APPLICATIONS - max section sqmm

Section sqmm	0.25-1.5	1.5-2.5	4-6	10	16	25	35	50	70	95	120	150	185	200	240	300	400	500	630	800	1000	
L.V. lugs and splices																						
Insulated terminals																						
"C" sleeve Connectors																						
Alu lugs and splices																						
H.V. lugs and splices																						

These tools are supplied without dies. For die selection, please refer to chart on pages 248 to 262



STORAGE

Type	VAL-130*
Purchase separately	✓

*Suitable for the storage of accessories for crimping Aluminium connectors

TECHNICAL FEATURES

Crimping force kN	130
Max operating pressure bar	700
Dimensions mm	
Length	245
Width	89
Weight kg	3,7

STORAGE

Type	VAL-P26*
Dimensions mm L x W x H	445 x 290 x 115
Weight kg	1,2
Purchase separately	✓

*Suitable for storage of the head and 14 sets of dies

STORAGE

Type	VAL-130*
Dimensions mm L x W x H	360 x 280 x 48
Weight kg	3,0
Purchase separately	✓

*Suitable for the storage of accessories for crimping Aluminium connectors

STORAGE

Type	VAL-130-U*
Dimensions mm L x W x H	450 x 305 x 80
Weight kg	5,0
Purchase separately	✓

*Suitable for storage of the head, semi-circular slotted dies and dies for crimping Aluminium connectors



HYDRAULIC PRESSHEAD

general features

MAIN APPLICATIONS - max section sqmm

Section sqmm	0.25÷1.5	1.5÷2.5	4÷6	10	16	25	35	50	70	95	120	150	185	200	240	300	400	500	630	800	1000	
L.V. lugs and splices																						
Insulated terminals																						
"C" sleeve Connectors																						
H.V. lugs and splices																						

These tools are supplied without dies. For die selection, please refer to chart on pages 248 to 262

STORAGE

Type	VAL-ECW-H3D*
Dimensions mm L x W x H	345 x 205 x 90
Weight kg	4,2
Supplied with the tool	-
Purchase separately	✓

* Suitable for storage of the head and 10 sets of dies

TECHNICAL FEATURES

Crimping force kN	230
Max operating pressure bar	700
Dimensions mm	
Length	290
Width	120
Weight kg	5,5

Hydraulic presshead complete with quick automatic coupler for connection to a hydraulic pump with a working pressure of 700 bar max, (see page 218-224).

Adaptor type AU230-130D is available as an optional extra enabling the head to utilise the semi-cir-

ECW-H3D ACCESSORIES FOR CUTTING CONDUCTORS

Die Type	Cutting Capacity	Conductor Type
	Ø 20 mm	Cu, Alu, Aldrey and Alu-Steel
	Ø 20 mm	Extra flexible Steel with ≥ 200 strands

WT-3D This die is suitable to cut Steel conductors (R ≤ 160 daN/mm²) having the most common strandings, i.e.:

19 x 1,2 = Ø est. 6,0 mm	7 x 3,0 = Ø est. 9,0 mm
19 x 2,1 = Ø est. 10,5 mm	19 x 2,3 = Ø est. 11,5 mm



cular slotted dies which are common to most 130 kN tools. Also available is a series of dies for the compression of DIN electrical connectors, and a die for cutting Copper, Aluminium, aldrej, Aluminium-Steel and Steel conductors.



HYDRAULIC PRESSHEAD

general features

MAIN APPLICATIONS - max section sqmm

Section sqmm	0.25÷1.5	1.5÷2.5	4÷6	10	16	25	35	50	70	95	120	150	185	200	240	300	400	500	630	800	1000	
Alu lugs and splices																						
Cu lugs and splices																						

These tools are supplied without dies. For die selection, please refer to chart on pages 248 to 262

STORAGE

Type	VAL-231*
Dimensions mm L x W x H	470 x 273 x 96
Weight kg	7,2
Supplied with the tool	✓
Purchase separately	-

* Suitable for storage of the head and dies for Aluminium compression

TECHNICAL FEATURES

Crimping force kN	230
Max operating pressure bar	700
Dimensions mm	
Length	320
Width	110
Weight kg	6,4

Hydraulic presshead complete with quick automatic coupler for connection to a hydraulic pump with a working pressure of 700 bar max, (see page 218-224).

For crimping up to 500 sqmm Aluminium.

Dies are available also for crimping Copper connectors.

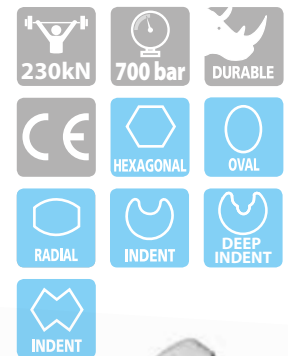

RHU230-630



Hydraulic presshead complete with quick automatic coupler for connection to a hydraulic pump with a working pressure of 700 bar max, (see page 218-224). It allows for crimping up to 630 sqmm Aluminium (according to HN 68 590).

HYDRAULIC PRESSHEAD

general features

MAIN APPLICATIONS - max section sqmm

Section sqmm	0.25±1.5	1.5±2.5	4-6	10	16	25	35	50	70	95	120	150	185	200	240	300	400	500	630	800	1000	
L.V. lugs and splices																						
Alu lugs and splices																						
"C" sleeve Connectors																						
H.V. lugs and splices																						

These tools are supplied without dies. For die selection, please refer to chart on pages 248 to 262

Adapters AU 230-130-C/N, and AU 230-PS/E, are available as an optional extra enabling the head to utilise the semicircular slotted dies which are common to most 130 kN tools.

TECHNICAL FEATURES

Crimping force kN	230
Max operating pressure bar	700
Dimensions mm	
Length	365
Width	193
Weight kg	9,0

STORAGE

Type	VAL-230-630*
Dimensions mm L x W x H	405 x 230 x 145
Weight kg	3,5
Supplied with the tool	✓
Purchase separately	-

*Suitable for storage of the head



VAL-230-630



VAL-MAT230-630

STORAGE

Type	VAL-MAT230-630*
Dimensions mm L x W x H	290 x 260 x 70
Weight kg	3,1
Purchase separately	✓

*Suitable for storage of the accessories

RHU450



Hydraulic presshead complete with quick automatic coupler for connection to a hydraulic pump with a working pressure of 700 bar max, (see page 218-224).

Adaptor type AU 450-130 D is available as an optional extra enabling the head to utilise the semi-circular slotted dies which are common to most 130 kN tools.

HYDRAULIC PRESSHEAD

general features

MAIN APPLICATIONS - Hexagonal crimp according to DIN 48083 max section sqmm

Section sqmm	0.25±1.5	1.5±2.5	4-6	10	16	25	35	50	70	95	120	150	185	200	240	300	400	500	680	800	1000	1200	
Cu																							
Al																							
Al/St																							

These tools are supplied without dies.

TECHNICAL FEATURES

Crimping force kN	450
Max operating pressure bar	700
Dimensions mm	
Length	260
Width	120
Weight kg	10,3

STORAGE

Type	VAL-450*
Dimensions mm L x W x H	285 x 212 x 124
Weight kg	2,8
Supplied with the tool	✓
Purchase separately	-

* Suitable for storage of the head



HYDRAULIC PRESSHEAD

RHU520

general features

MAIN APPLICATIONS - max section sqmm

Section sqmm	0.25-1.5	1.5-2.5	4-6	10	16	25	35	50	70	95	120	150	185	200	240	300	400	500	630	800	1000	1200	
Lugs and splices																							
H.V. overhead lines																							

These tools are supplied without dies. For die selection, please refer to chart on pages 248 to 262



STORAGE

Type	VAL-520*
Dimensions mm L x W x H	384 x 231 x 145
Weight kg	3,2
Supplied with the tool	-
Purchase separately	✓

*Suitable for storage of the head

TECHNICAL FEATURES

Crimping force kN	520
Max operating pressure bar	700
Dimensions mm	
Length	306
Width	200
Weight kg	18,0

STORAGE

Type	VAL-MAT 520*
Dimensions mm L x W x H	500 x 310 x 68
Weight kg	5,1
Supplied with the tool	-
Purchase separately	✓

*Suitable for storage of 10 sets of dies



Hydraulic presshead complete with quick automatic coupler for connection to a hydraulic pump with a working pressure of 700 bar max, (see page 218-224). Adaptor type AU520-130C is available as an optional extra enabling the head to utilise the semi-circular slotted dies which are common to most 130 kN tools.

RHU600

HYDRAULIC PRESSHEAD

general features



MAIN APPLICATIONS

- "U" Alcoa series die and "L" Burndy series die, etc.
- Aluminium and Copper max size 2156 MCM

These tools are supplied without dies. For die selection, please refer to chart on pages 248 to 262



TECHNICAL FEATURES

Crimping force kN	600
Max operating pressure bar	700
Dimensions with support mm	
Length	447
Width	241
Weight with support	22,4

STORAGE

Type	VAL-600*
Dimensions mm L x W x H	480 x 235 x 260
Weight kg	8,6
Supplied with the tool	✓
Purchase separately	-

*Suitable for storage of the head



VAL-600

Hydraulic presshead complete with quick automatic coupler for connection to a hydraulic pump with a working pressure of 700 bar max, (see page 218-224).

HYDRAULIC PRESSHEAD

RHU1000

general features

These tools are supplied without dies. For die selection, please refer to chart on pages 248 to 262



STORAGE

Type	VAL-1000*
Dimensions mm L x W x H	334 x 244 x 435
Weight kg	12
Supplied with the tool	✓
Purchase separately	-

*Suitable for storage of the head

TECHNICAL FEATURES

Crimping force kN	1.100
Max operating pressure bar	700
Dimensions mm	
Length	414
Width	278
Weight kg	50,6

Operable from single or double acting hydraulic power source



VAL-1000



Lifting eye; screwed into the base of the cylinder, allows easy transportation of the head in aerial operation.

RHU 1000 is a 1.100 kN hydraulic presshead for full tension, transmission and substation connections, complete with quick automatic coupler for connection to hydraulic pumps with a working pressure of 700 bar max, (see page 218-224).

The standard version must be operated by a single acting pump; possibility to convert from single to double acting by substitution of the breather valve with a female quick coupling. RHU1000 will accept all semi-circular slotted dies common to most 100 ton heads as the Alcoa ones.

The die cap is removable for an easy connector positioning; the upper part of the cap automatically rotates during the die changing process to present the correct positioning of the die. Lifting eye included.

Insertion of the upper die:



After substitution of the dies, insert the die cap into the head.



Pull the pin.



The upper part of the cap automatically rotates...



...to the correct position.

HT-TC051

HYDRAULIC CUTTING TOOL

industrial application

MAIN APPLICATIONS

specifically designed to cut Copper, Aluminium and Telecommunications cable having Ø max 50 mm



Hand operated hydraulic tool specifically designed to cut Copper, Aluminium and Telecommunications cable having a max overall diameter of 50 mm.

The tool features a double speed action: a fast advancing speed for rapid approach of the blades to the cable and a slower more powerful speed for cutting.

TECHNICAL FEATURES

Max cutting Ø mm	50
Dimensions mm	
Length	497
Width	129
Weight kg	4,38

STORAGE

Type	CVB-010
Dimensions mm L x W	545 x 160
Weight kg	0,15
Supplied with the tool	✓
Purchase separately	-



The blades are manufactured from high strength special Steel, heat treated to ensure a long service life. The head can be easily opened to allow the cutting of running cables. The head can rotate through 90 degrees, to enable the operator to work in the most comfortable position. HT-TC051 features an automatic safety valve to bypass oil when reaching maximum pressure; a pressure release device can also be operated at any stage of operation.

TC050

HYDRAULIC CUTTING HEAD

industrial application

MAIN APPLICATIONS

specifically designed to cut Copper, Aluminium and Telecommunications cable having Ø max 50 mm



Hydraulic cutting head complete with quick automatic coupler for connection to a hydraulic pump with a working pressure of 700 bar max, (see page 218-224)

TC050 features the same cutting capability as HT-TC051.

TECHNICAL FEATURES

Max cutting Ø mm	50
Max operating pressure bar	700
Dimensions mm	
Length	325
Width	112
Weight kg	3,2

STORAGE

Type	CVB-011
Dimensions mm L x W	360 x 137
Weight kg	0,13
Supplied with the tool	✓
Purchase separately	-



HYDRAULIC CUTTING TOOL

industrial application

MAIN APPLICATIONS

specifically designed to cut Copper, Aluminium and Telecommunications cable having Ø max 65 mm

STORAGE

Type	CVB-010
Dimensions mm L x W	545 x 160
Weight kg	0,15
Supplied with the tool	✓
Purchase separately	-

TECHNICAL FEATURES

Max cutting Ø mm	65
Dimensions mm	
Length	523
Width	129
Weight kg	5



Hand operated hydraulic tool specifically designed to cut Copper, Aluminium and Telecommunications cable having a max overall diameter of 65 mm.

The tool features a double speed action.

The blades are manufactured from high strength special Steel, heat treated to ensure a long service life. The head can be easily opened to allow the cutting of running cables.

HT-TC065



The head can rotate through 320 degrees, to enable the operator to work in the most comfortable position. HT-TC065 features an automatic safety valve to bypass oil when reaching maximum pressure; a pressure release device can also be operated at any stage of operation.

HYDRAULIC CUTTING HEAD

industrial application

MAIN APPLICATIONS

specifically designed to cut Copper, Aluminium and Telecommunications cable having Ø max 65 mm

STORAGE

Type	VAL-TC065-SC*
Dimensions mm L x W x H	459 x 231 x 122
Weight kg	3,6
Supplied with the tool	✓
Purchase separately	-

*Suitable for storage of the head

TECHNICAL FEATURES

Max cutting Ø mm	65
Max operating pressure bar	700
Dimensions mm	
Length	426
Width	185
Weight kg	6,3

Hydraulic cutting head complete with quick automatic coupler for connection to a hydraulic pump with a working pressure of 700 bar max, (see page 218-224) TC065-SC features the same cutting capability as HT-TC065.

TC065-SC



The open head and the "scissor" movement of the blades facilitate the cutting of running cables.

HT-TC0851

HYDRAULIC CUTTING TOOL

industrial application

MAIN APPLICATIONS

specifically designed to cut Copper, Aluminium and Telecommunications cable having Ø max 85 mm

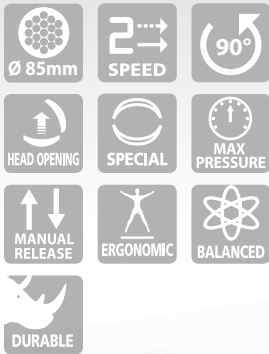

Hand operated hydraulic tool specifically designed to cut Copper, Aluminium and Telecommunications cable having a max overall diameter of 85 mm.

New model, self contained, robust and sturdy. The tool features a double speed action: a fast advancing speed for rapid approach of the blades to the cable and a slower more powerful speed for cutting.

TECHNICAL FEATURES

Max cutting Ø mm	85
Dimensions mm	
Length	652,5
Width	175
Weight kg	6,6

STORAGE

Type	VAL-P7
Dimensions mm L x W x H	727 x 202 x 115
Weight kg	1,3
Supplied with the tool	✓
Purchase separately	-

The blades are manufactured from high strength special Steel, heat treated to ensure a long service life. The head can easily be opened to allow the cutting of running cables, and can rotate through 180 degrees, to enable the operator to work in the most comfortable position.

HT-TC0851 features an automatic safety valve to bypass oil when reaching maximum pressure; a pressure release device can also be operated at any stage of operation.



TC085

HYDRAULIC CUTTING HEAD

industrial application

MAIN APPLICATIONS

specifically designed to cut Copper, Aluminium and Telecommunications cable having Ø max 85 mm



Hydraulic cutting head complete with quick automatic coupler for connection to a hydraulic pump with a working pressure of 700 bar max, (see page 218-224) TC085 features the same cutting capability as HT-TC0851.

TECHNICAL FEATURES

Max cutting Ø mm	85
Max operating pressure bar	700
Dimensions mm	
Length	409
Width	135
Weight kg	4,9

STORAGE

Type	VAL-TC085
Dimensions mm L x W x H	465 x 155 x 65
Weight kg	2,4
Supplied with the tool	✓
Purchase separately	-



HYDRAULIC CUTTING HEAD

industrial application

MAIN APPLICATIONS

specifically designed to cut Copper and Aluminium cable having Ø max 95 mm

STORAGE

Type	VAL-096
Dimensions mm L x W x H	450 x 265 x 145
Weight kg	6,8
Supplied with the tool	✓
Purchase separately	-



TECHNICAL FEATURES

Max cutting Ø mm	95
Max operating pressure bar	700
Dimensions mm	
Length	397
Width	249
Weight kg	7,9



Hydraulic cutting head specifically designed to cut Copper and Aluminium cable having a max overall diameter of 95 mm.

The head is complete with a quick automatic coupler for connection to a hydraulic pump with a working pressure of 700 bar max, (see page 218-224).



HYDRAULIC CUTTING HEAD

industrial application

MAIN APPLICATIONS

specifically designed to cut Copper, Aluminium and Telecommunications cable having Ø max 120 mm

STORAGE

Type	VAL-TC120
Dimensions mm L x W x H	590 x 209 x 84
Weight kg	4,9
Supplied with the tool	✓
Purchase separately	-



TECHNICAL FEATURES

Max cutting Ø mm	120
Max operating pressure bar	700
Dimensions mm	
Length	536
Width	175
Weight kg	9,5

Hydraulic cutting head specifically designed to cut Copper, Aluminium and Telecommunications cable having a max overall diameter of 120 mm. The head can easily be opened to cut running cables, and the handle allows the most comfortable po-

sitioning of the head onto the cable to be cut.

The head is complete with a quick automatic coupler for connection to a hydraulic pump with a working pressure of 700 bar max, (see page 218-224).

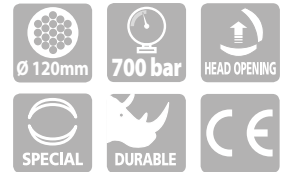

TC 120 cutting capacity - a few examples:

Section	Conductor Type
3x150 mm ²	Steel armoured Ø80 mm
1000 mm ²	Cu - EPR rubber insulated; Ø85 mm
1000 mm ²	Cu - EPR rubber insulated + lead sheath; Ø92 mm
1000 mm ²	Cu - EPR rubber insulated + lead sheath + PE sheath; Ø100 mm
240 mm ²	EPR rubber insulated



HT-TC026

HYDRAULIC CUTTING TOOL

overhead line application

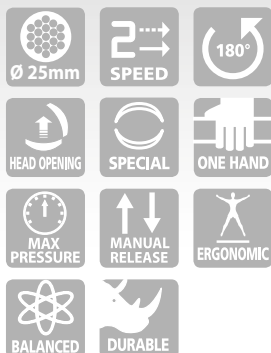

MAIN APPLICATIONS

specifically designed to cut Copper, aldrej, Aluminium, Aluminium-Steel cables and Steel ropes, Aluminium and Steel rods having Ø max 25 mm

The blades are manufactured from high strength special Steel, heat treated to ensure a long service life.

The head can rotate through 180 degrees, to enable the operator to work in the most comfortable position, and can easily be opened to allow the cutting of running cables.

HT-TC026 features an automatic safety valve to bypass oil when reaching maximum pressure; a pressure release device can also be operated at any stage of operation.

TECHNICAL FEATURES

Max cutting Ø mm	25
Dimensions mm	
Length	382
Width	129
Weight kg	3,2

STORAGE

Type	CVB-001
Dimensions mm L x W	430 x 155
Weight kg	0,15
Supplied with the tool	✓
Purchase separately	-



Hand operated hydraulic tool specifically designed to cut Copper, aluminium, Aluminium-Steel cables and Steel ropes, Aluminium and Steel rods having a max overall diameter of 25 mm. The tool features a double speed action: a fast advancing speed for rapid approach of the blades to the cable and a slower more powerful speed for cutting.



CUTTING CAPACITY

	MATERIAL	TENSILE STRENGTH (daN/mm ²)	MAX CUTTING DIAMETER (mm)	
			HT-TC026 TC 025	HT-TC026Y B-TC250
ROPE & CONDUCTORS	COPPER	≤ 41	25	
	ALUMINIUM	≤ 20	25	
	ALMELEC	≤ 34	25	
	STEEL	≤ 180	INDICATIVE EXAMPLES: 7 x 3,0 : Ø est. = 9,0 mm 19 x 2,1 : Ø est. = 10,5 mm 19 x 2,3 : Ø est. = 11,5 mm	
	MULTI STRANDS STEEL (STRANDS Qty ≥ 200)	≤ 180	18	
RODS	ACSR	≤ 180	25 INDICATIVE EXAMPLES: 26 x 2,50 + 7 x 1,95 : Ø est. = 15,85 26 x 3,06 + 7 x 2,38 : Ø est. = 19,38 26 x 3,60 + 7 x 2,80 : Ø est. = 22,80	
			STEEL	≤ 60
	STEEL	≤ 42	16	
		≤ 30	20	
		≤ 25	23	
ALUMINIUM	≤ 16	25		

TC025

HYDRAULIC CUTTING HEAD

overhead line application



MAIN APPLICATIONS

specifically designed to cut Copper, aldrej, Aluminium, Aluminium-Steel cables and Steel ropes, Aluminium and Steel rods having Ø max 25 mm

Hydraulic cutting head complete with quick automatic coupler for connection to a hydraulic pump with a working pressure of 700 bar max, (see page 218-224)

TC025 has the same cutting capability as HT-TC026.

TECHNICAL FEATURES

Max cutting Ø mm	25
Max operating pressure bar	700
Dimensions mm	
Length	213
Width	82
Weight kg	2,0

STORAGE

Type	CVB-007
Dimensions mm L x W	350 x 105
Weight kg	0,13
Supplied with the tool	✓
Purchase separately	-



HYDRAULIC CUTTING TOOL

HT-TC026Y

overhead line application

MAIN APPLICATIONS

specifically designed to cut Copper, aldrej, Aluminum, Aluminum-Steel cables, stay wire and Steel ropes having Ø max 25 mm and Steel earthing rod up to 16 mm.



STORAGE

Type	CVB-001
Dimensions mm L x W	430 x 155
Weight kg	0,15
Supplied with the tool	✓
Purchase separately	-

TECHNICAL FEATURES

Max cutting Ø mm	25
Dimensions mm	
Length	394,5
Width	129
Weight kg	3,35

Hand operated hydraulic tool specifically designed to cut Copper, aldrej, Aluminum, Aluminum-Steel cables, stay wire and Steel ropes having a max overall diameter of 25 mm and Steel earthing rod up to 16 mm. The tool features a double speed action.

The blades are manufactured from high strength special Steel, heat treated to ensure a long service life.



The head can rotate through 180 degrees, to enable the operator to work in the most comfortable position, and can easily be opened to allow the cutting of running cables. HT-TC026Y features an automatic safety valve to bypass oil when reaching maximum pressure; a pressure release device can also be operated at any stage of operation.

Ideal for earthing rod and stay wire

HT-TC026Y cutting capacity - a few examples:

Ø		EARTHING RODS AND STAY WIRES
mm	in.	
14,2	/	STEEL EARTHING ROD, COPPER PLATED; Tensile strength = 79 daN/mm ²
12,7	1/2"	STEEL EARTHING ROD, COPPER PLATED; Tensile strength = 69 daN/mm ²
15,6	/	STEEL EARTHING ROD; Tensile strength = 69 daN/mm ²
15,9	5/8"	STEEL EARTHING ROD, COPPER PLATED (CON ED - ILLINOIS); Tensile strength = 57 daN/mm ²
15,9	5/8»	STEEL EARTHING ROD, COPPER PLATED (CON ED - STATEN ISLAND); Tensile strength = 78 daN/mm ²
19	3/4"	STEEL EARTHING ROD, COPPER PLATED; Tensile strength = 74 daN/mm ²
9,15 (3,05x7)	/	STAY WIRE
10,8 (3,6x7)	/	STAY WIRE (PORTLAND GENERAL ELECTRIC)
11,1 (3,7x7)	/	STAY WIRE (PORTLAND GENERAL ELECTRIC)
12,3 (4,1x7)	/	STAY WIRE (PORTLAND GENERAL ELECTRIC)
12,6 (4,2x7)	/	STAY WIRE (PORTLAND GENERAL ELECTRIC)

HT-TC041N

HYDRAULIC CUTTING TOOL

overhead line application



MAIN APPLICATIONS

specifically designed to cut Copper, aldrej, Aluminium, Aluminium-Steel cables and Steel ropes, Aluminium and Steel rods having Ø max 45 mm

New model, even more self contained, robust and sturdy. The blades are manufactured from high strength special Steel, heat treated to ensure a long service life. The head can rotate through 180 degrees, to enable the operator to work in the most comfortable position, and can easily be opened to allow cutting of running cables.

TECHNICAL FEATURES

Max cutting Ø mm	45
Dimensions mm	
Length	550
Width	144
Weight kg	5,8

STORAGE

Type	VAL-P7
Dimensions mm L x W x H	727 x 202 x 115
Weight kg	1,3
Supplied with the tool	✓
Purchase separately	-

HT-TC041N features an automatic safety valve to bypass oil when reaching maximum pressure; a pres-

sure release device can also be operated at any stage of operation.

CUTTING CAPACITY

MATERIAL	TENSILE STRENGTH (daN/mm ²)	MAX CUTTING DIAMETER (mm)	
		HT-TC041N	TC04N B-TC450
COPPER	≤ 41	45	
ALUMINIUM	≤ 20	45	
ALMELEC	≤ 34	45	
ROPE & CONDUCTORS	STEEL	INDICATIVE EXAMPLES: 7 x 3,0 : Ø est. = 9,0 mm 19 x 2,1 : Ø est. = 10,5 mm 19 x 2,3 : Ø est. = 11,5 mm	
	MULTI STRANDS STEEL (STRANDS Qty ≥ 200)	18	
	ACSR	45 INDICATIVE EXAMPLES: 26 x 2,50 + 7 x 1,95 : Ø est. = 15,85 26 x 3,06 + 7 x 2,38 : Ø est. = 19,38 26 x 3,60 + 7 x 2,80 : Ø est. = 22,80 54 x 3,50 + 19 x 2,10 : Ø est. = 31,50 54 x 4,36 + 19 x 2,62 : Ø est. = 39,20	
RODS	STEEL	≤ 60	18
		≤ 42	20
	COPPER	≤ 30	30
		≤ 25	32
		≤ 16	45



Hand operated hydraulic tool specifically designed to cut Copper, aldrej, Aluminium, Aluminium-Steel cables and Steel ropes, Aluminium and Steel rods having a max overall diameter of 45 mm.

TC04N

HYDRAULIC CUTTING HEAD

overhead line application



MAIN APPLICATIONS

specifically designed to cut Copper, aldrej, Aluminium, Aluminium-Steel cables and Steel ropes, Aluminium and Steel rods having Ø max 45 mm

Hydraulic cutting head complete with quick automatic coupler for connection to a hydraulic pump with a working pressure of 700 bar max, (see page 218-224)

TC04N has the same cutting capability as HT-TC041N.

TECHNICAL FEATURES

Max cutting Ø mm	45
Max operating pressure bar	700
Dimensions mm	
Length	311
Width	100
Weight kg	4,0

STORAGE

Type	VAL-04
Dimensions mm L x W x H	350 x 125 x 68
Weight kg	2,0
Supplied with the tool	✓
Purchase separately	-



HYDRAULIC CUTTING TOOL

overhead line application

MAIN APPLICATIONS

specifically designed to cut Copper, Aluminum, Aluminum-Steel cables (ACSR) having Ø max 50 mm
Not suitable for cutting stay wire, Steel rope or earthing rod

STORAGE

Type	CVB-010
Dimensions mm L x W	545 x 160
Weight kg	0,15
Supplied with the tool	✓
Purchase separately	-

TECHNICAL FEATURES

Max cutting Ø mm	50
Dimensions mm	
Length	503
Width	129
Weight kg	4,7

Hand operated hydraulic tool specifically designed to cut Copper, Aluminum, Aluminum-Steel cables (ACSR) having a max overall diameter of 50 mm.

The HT-TC051Y is provided with a two stage hydraulic system, which advances the blades quickly to the cable. This proven system saves operator time and effort.



The HT-TC051Y is provided with an automatic safety valve to bypass oil when reaching max pressure. This means safety to the operator and protection to the blades. The blades are manufactured from high strength special Steel, heat treated to ensure a long service life. The shape of the blades provides a "clean" cut. The head can be opened to allow cutting of running cables and ropes. The head rotates 90 degrees allowing the operator to perform the cut in the most comfortable position. The tool is supplied complete with canvas bag 010 for protection and storage when not in use.

HYDRAULIC CUTTING HEAD

overhead line application

MAIN APPLICATIONS

specifically designed to cut Copper, Aluminum, Aluminum-Steel cables (ACSR) having Ø max 50 mm
Not suitable for cutting stay wire, Steel rope or earthing rod

STORAGE

Type	CVB-011
Dimensions mm L x W x H	360 x 137
Weight kg	0,13
Supplied with the tool	✓
Purchase separately	-

TECHNICAL FEATURES

Max cutting Ø mm	50
Max operating pressure bar	700
Dimensions mm	
Length	331
Width	112
Weight kg	3,3

Hydraulic cutting head complete with quick automatic coupler for connection to a hydraulic pump with a working pressure of 700 bar max, (see page 218-224).

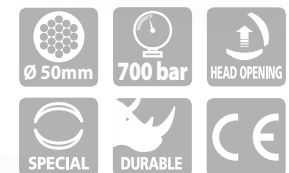

TC050Y features the same cutting capability as HT-TC051Y.

HT-TC055

HYDRAULIC CUTTING TOOL

overhead line application

MAIN APPLICATIONS

specifically designed to cut Copper, aldrej, Aluminium, Aluminium-Steel cables and Steel ropes, Aluminium and Steel rods having Ø max 55 mm

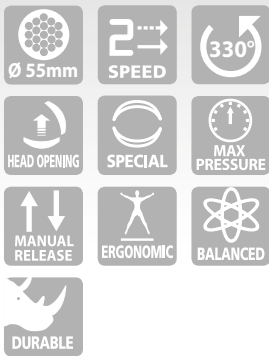

Hand operated hydraulic tool specifically designed to cut Copper, aldrej, Aluminium, Aluminium-Steel cables and Steel ropes, Aluminium and Steel rods having a max overall diameter of 55 mm.



The HT-TC055 is provided with a two stage hydraulic system, which advances the blades quickly to the cable.

This proven system saves operator time and effort.

The HT-TC055 is provided with an automatic safety valve to bypass oil when reaching max pressure.

This means safety to the operator and protection to the blades.

The blades are manufactured from high strength special Steel, heat treated to ensure a long service life. The shape of the blades provides a "clean" cut. The head can be opened to allow cutting of running cables and ropes. The head rotates 330 degrees allowing the operator to perform the cut in the most comfortable position. The tool is supplied complete with plastic case VAL P7 for protection and storage when not in use.

TECHNICAL FEATURES

Max cutting Ø mm	55
Dimensions mm	
Length	595
Width	144
Weight kg	8,3

STORAGE

Type	VAL-P7
Dimensions mm L x W x H	727 x 202 x 115
Weight kg	1,3
Supplied with the tool	✓
Purchase separately	-

CUTTING CAPACITY

MATERIAL	TENSILE STRENGTH (daN/mm ²)	MAX CUTTING DIAMETER (mm)	
		HT-TC055	B-TC550
COPPER	≤ 41	55	
ALUMINIUM	≤ 20	55	
ALMELEC	≤ 34	55	
STEEL	≤ 180	INDICATIVE EXAMPLES: 7 x 3,0 : Ø est. = 9,0 mm 19 x 2,1 : Ø est. = 10,5 mm 19 x 2,3 : Ø est. = 11,5 mm	
MULTI STRANDS STEEL (STRANDS Qty ≥ 200)	≤ 180	22	
ACSR	≤ 180	50 INDICATIVE EXAMPLES: 26 x 2,50 + 7 x 1,95 : Ø est. = 15,85 26 x 3,06 + 7 x 2,38 : Ø est. = 19,38 26 x 3,60 + 7 x 2,80 : Ø est. = 22,80 26 x 4,44 + 7 x 3,45 : Ø est. = 28,14 54 x 3,50 + 19 x 2,10 : Ø est. = 31,50 54 x 4,36 + 19 x 2,62 : Ø est. = 39,20 83 x 4,60 + 16 x 2,80 : Ø est. = 50,00	
GUY WIRE (GW15-9/16-188)	Extra high strength grade	7 x 4,77 : Ø est. = 14,30 mm	
STEEL	≤ 60	20	
	≤ 42	22	
COPPER	≤ 30	34	
	≤ 25	38,5	
ALUMINIUM	≤ 16	50	

TC055

HYDRAULIC CUTTING HEAD

overhead line application

MAIN APPLICATIONS

specifically designed to cut Copper, aldrej, Aluminium, Aluminium-Steel cables and Steel ropes, Aluminium and Steel rods having Ø max 55 mm



Hydraulic cutting head complete with quick automatic coupler for connection to a hydraulic pump with a working pressure of 700 bar max, (see page 218-224)

TC055 has the same cutting capability as HT-TC055.

TECHNICAL FEATURES

Max cutting Ø mm	55
Max operating pressure bar	700
Dimensions mm	
Length	357
Width	134
Weight kg	6,6

STORAGE

Type	VAL-TC055
Dimensions mm L x W x H	384 x 231 x 145
Weight kg	3,7
Supplied with the tool	✓
Purchase separately	-



FRAME-TYPE HOLE PUNCHING HEAD

RH-FC48N

general features

MAIN APPLICATIONS

designed for punching holes from 15,5 up to 47,2 mm diameter

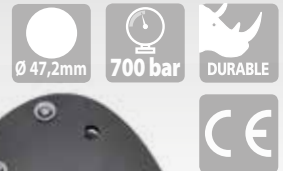

TECHNICAL FEATURES

Max piercing Ø mm	47,2
Max centre of hole to edge of trunking (mm)	53,5
Max operating pressure bar	700
Dimensions mm	
Length	259,5
Width	147,5
Weight kg	3,7

STORAGE

Type	VAL-P30
Dimensions mm L x W x H	315 x 300 x 95
Weight kg	0,93
Supplied with the tool	✓
Purchase separately	-



Table denotes the punch/die set reference, for each hole size. Suitable for punching holes in mild Steel, fibreglass or plastic material, up to 2 mm thick.

Hole Dimensions				Maximum thickness of mild Steel (mm)	Type
Nominal		Pg	ISO		
Ø (mm)	Ø (inch)				
15,5	.610	Pg9	-	-	RD15.5SS-FC
16,2	.638	-	ISO-16	-	RD16.2SS-FC
17,5	.689	-	-	-	RD17.5SS-FC
18,8	.740	Pg11	-	-	RD18.8SS-FC
19,1	.752	-	-	-	RD19.1SS
20,5	.807	Pg 13,5	ISO-20	-	RD20.5SS
22,6	.890	Pg16	-	-	RD22.6SS
23,8	.937	-	-	5/8"	RD23.8SS
25,4	1.000	-	ISO-25	-	RD25.4SS
27,0	1.063	-	-	3/4"	RD27SS
28,5	1.122	Pg21	-	-	RD28.5SS
30,5	1.201	-	-	7/8"	RD30.5SS
31,8	1.252	-	-	-	RD31.8SS
32,5	1.279	-	ISO-32	-	RD32.5SS
34,6	1.362	-	-	-	RD34.6SS
37,2	1.464	Pg29	-	-	RD37.2SS
38,1	1.500	-	-	-	RD38.1SS
40,5	1.594	-	ISO-40	-	RD40.5SS-FC
41,3	1.626	-	-	-	RD41.3SS-FC
42,5	1.673	-	-	1 1/4"	RD42.5SS-FC
43,2	1.701	-	-	-	RD43.2SS-FC
44,5	1.752	-	-	-	RD44.5SS-FC
47,2	1.858	Pg36	-	-	RD47.2SS-FC



Hydraulic head complete with automatic quick coupler, designed for punching holes from 15,5 up to 47,2 mm diameter in the side wall of trunking without the need for pre drilling.

For operation, the head must be joined to a hydraulic pump developing a pressure of 700 bar (see page 218-224).

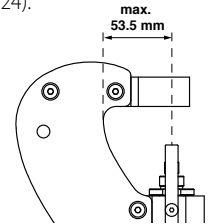

PIERCING HEADS

general features

RHT160

Max piercing Ø mm	21
Max hole distance from bar edge (mm)	30
Max operating pressure bar	700
Dimensions mm	
Length	240
Width	153
Weight kg	6,5

RHT160-60N

Max piercing Ø mm	21
Max hole distance from bar edge (mm)	60
Max operating pressure bar	700
Dimensions mm	
Length	240
Width	181
Weight kg	9,2

STORAGE

Type	VAL-160*
Dimensions mm L x W x H	283 x 180 x 100
Weight kg	2,3
Supplied with the tool	✓
Purchase separately	-

*Suitable for storage of the head



RHT160 RHT160-60N

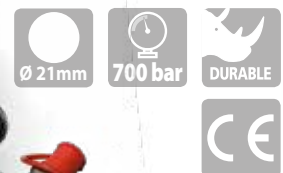

Hydraulic head complete with automatic quick coupler, for piercing holes of various diameters in Copper, Aluminium and Steel bars with max. thickness of 10 mm.

This compact and handy tool is widely used for transformer room connections, control switch boards and power plants.

For operation the head must be joined to a hydraulic pump developing a pressure of 700 bar (see page 218-224).

Available accessories (to be ordered separately):

Piercing Ø mm	6,5	8,5	9	10,5	11	13	13,5	14	15	17	19	21
Type (Kit Punch+Die)	RT6,5	RT8,5	RT9	RT10,5	RT11	RT13	RT13,5	RT14	RT15	RT17	RT19	RT21
Max. thickness												
Hole diameter (mm)	6,5	8,5	9	10,5	11	13	13,5	14	15	17	19	21
Max thickness strep in Copper	10	10	10	10	10	10	10	10	10	10	8	8
Max thickness strep in Steel	10	10	10	10	10	9	9	9	8	7	6	4
Punch die/set	RT6,5	RT8,5	RT9	RT10,5	RT11	RT13	RT13,5	RT14	RT15	RT17	RT19	RT21

HT-FL74

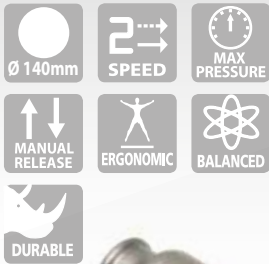

Hand operated hydraulic tool specifically designed for hole punching stainless Steel, mild Steel, fibreglass and plastic sheet materials up to 3,5 mm thickness. Compact, lightweight and easy to handle. The tool is supplied complete with plastic case VAL P28 for protection

and storage when not in use. Supplied with Pullers TD-11, TD-19 and spiral bit Ø 11,5 mm. For the punch-die selection chart see page 177.

TECHNICAL FEATURES

Max Punching Ø mm	140
Dimensions mm	
Length	381
Width	138
Weight kg	3,3

STORAGE

Type	VAL-P28
Dimensions mm L x W x H	620 x 360 x 138
Weight kg	2,4
Supplied with the tool	✓
Purchase separately	-



HT-FL75



Hand operated hydraulic tool specifically designed for hole punching stainless Steel, mild Steel, fibreglass and plastic sheet materials up to 3,5 mm thickness. Compact, lightweight and easy to handle. The balanced punching head pivots 180deg through a full 360deg rotation for ease of use in confined spaces.

The tool is supplied complete with plastic case VAL P28 for protection and storage when not in use. Supplied with Pullers TD-11, TD-19 and spiral bit Ø 11,5 mm. For the punch-die selection chart see page 177.

TECHNICAL FEATURES

Max Punching Ø mm	140
Dimensions mm	
Length	452
Width	138
Weight kg	3,67

STORAGE

Type	VAL-P28
Dimensions mm L x W x H	620 x 360 x 138
Weight kg	2,4
Supplied with the tool	✓
Purchase separately	-



KIT-HT-FL75-1



HOLE PUNCHING KIT

general features

KIT-HT-FL75-1

Kit includes:

HT-FL75 Puller-type hole punching hydraulic tool

VAL P28 plastic carrying case with accessories

Puller TD-11

Puller TD-19

spiral bit Ø 11,5 mm

4 KIT for round punch:

KIT-RD18.8SS Pg11

KIT-RD20.5SS Pg13.5

KIT-RD22.6SS Pg16

KIT-RD28.5SS Pg21

PULLER-TYPE HOLE PUNCHING HEAD

RH-FL75

general features

MAIN APPLICATIONS

specifically designed for hole punching stainless Steel, mild Steel, fibreglass and plastic sheet materials up to 3,5 mm thickness

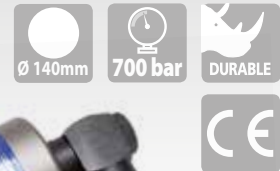

STORAGE

Type	VAL-P29
Dimensions mm L x W x H	448 x 288 x 105
Weight kg	1,4
Supplied with the tool	✓
Purchase separately	-

TECHNICAL FEATURES

Max Punching Ø mm	140
Max operating pressure bar	700
Dimensions mm	
Length	163
Width	106
Weight kg	1,9



Hydraulic head, for hole punching stainless Steel, mild Steel, fibreglass and plastic sheet materials up to 3,5 mm thickness.

pump with a working pressure of 700 bar max (see page 218-224). Supplied with Pullers TD-11, TD-19 and spiral bit Ø 11,5 mm.

Compact and lightweight, easy to handle in confined spaces due to a rotating 90deg quick automatic coupler for connection to a hydraulic

For the punch-die selection chart see table below.



HT-FL74, HT-FL75 and RH-FL75 Punching accessories available

Round punch

Hole diameter				Material max thickness (mm)		Pilot hole Ø (mm)	Type	
Nominal Ø (mm)	Ø (inch)	Pg	ISO	Stainless Steel	Mild Steel		KIT (Punch+Die)	Puller
15,5	.610	Pg9	-	2,5 mm (0,1 in.) Rm= 700 N/mm ²	3,5 mm (0,14 in.) Rm= 510 N/mm ²	11,5	TD-11	RD15.5SS
16,2	.638	-	ISO-16					RD16.2SS
17,0	.669	-	G3/8"					RD17.5SS
17,5	.689	-	-					RD18.8SS
18,8	.740	Pg11	-					RD19.1SS
19,1	.752	-	-					RD20.5SS
20,5	.807	Pg 13,5	ISO-20					RD21.5SS
21,5	.846	-	G1/2"					RD22.6SS
22,6	.890	Pg16	-					RD23.8SS
23,8	.937	-	G5/8"					RD25.4SS
25,4	1.000	-	ISO-25					RD27.5SS
27,0	1.063	-	G3/4"			RD28.5SS		
28,5	1.122	Pg21	-			RD30.5SS		
30,5	1.201	-	G7/8"			RD28.5SS-19		
28,5	1.122	Pg 21	-			RD30.5SS-19		
30,5	1.201	-	G7/8"			RD31.8SS		
31,8	1.252	-	-			RD32.5SS		
32,5	1.279	-	ISO-32			RD34.5SS		
34,0	1.338	-	G1"			RD34.6SS		
34,6	1.362	-	-			RD37.2SS		
37,2	1.464	Pg29	-			RD38.1SS		
38,1	1.500	-	-			RD38.5SS		
38,5	1.515	-	G1 1/8"			RD40.5SS		
40,5	1.594	-	ISO-40			RD41.3SS		
41,3	1.626	-	-			RD42.5SS		
42,5	1.673	-	G1 1/4"			RD43.2SS		
43,2	1.701	-	-			RD44.5SS		
44,5	1.752	-	-			RD47.2SS		
47,2	1.858	Pg36	-			RD48.5SS		
48,5	1.909	-	G1 1/2"			RD50.5SS		
50,5	1.988	-	ISO-50			RD51.4SS		
51,4	2.023	-	-			RD52.4SS		
52,4	2.063	-	-			RD54.2SS		
54,2	2.134	Pg42	-	RD54.2SS				
60,0	2.362	Pg48	-	RD60.5SS				
60,5	2.381	-	G2"	RD60.5SS				
64,0	2.520	-	ISO-63	RD64.5SS				
65,0	2.559	-	-	RD65.5SS				
76,0	2.992	-	G2 1/2"	RD76.5SS				
76,5	3.011	-	-	RD76.5SS				
80,5	3.169	-	-	RD80.5SS				
89,0	3.503	-	G3"	RD89.5SS				
90,0	3.543	-	-	RD90.5SS				
100,0	3.937	-	-	RD100.5SS				
102,0	4.015	-	-	RD102.5SS				
114,0	4.488	-	-	RD114.5SS				
120,0	4.724	-	-	RD120.5SS				
140,0	5.512	-	-	RD140.5SS				

* Puller included in the kit

"D" punch

Hole diameter		Material max thickness (mm)		Pilot hole Ø (mm)	Type
Nominal (mm)	(inch)	Stainless Steel	Mild Steel		
(a)38,3 x (b)36,6	(a)1.507 x (b)1.442	2,5	3,5	18,5	KIT (Punch+die + Puller)
(a)43,1 x (b)41,5	(a)1.696 x (b)1.632				

Stainless Steel = Rm= 700 N/mm² - Mild Steel = Rm= 500 N/mm²

Square punch

Hole diameter		Material max thickness (mm)		Pilot hole Ø (mm)	Type
Nominal (mm)	(inch)	Stainless Steel	Mild Steel		
21,0 x 21,0	.827 x .827	2,5	3,5	12,0	KIT (Punch+die + Puller)
46,0 x 46,0	1.811 x 1.811				
68,0 x 68,0	2.677 x 2.677	1,5	2,0	26,5	RD21X21
92,0 x 92,0	3.622 x 3.622				
126,0 x 126,0	4.960 x 4.960				
138,0 x 138,0	5.433 x 5.433				
220,0 x 220,0	8.661 x 8.661	1,0	1,5	28,5	RD68X68
224,0 x 224,0	8.818 x 8.818				

Rectangular punch

Hole diameter		Material max thickness (mm)		Pilot hole Ø (mm)	Type
Nominal (mm)	(inch)	Stainless Steel	Mild Steel		
18,0 x 46,0	.709 x 1.811	2,0	2,0	16,5	RD18X46
22,0 x 30,0	.866 x 1.181				
22,0 x 46,0	.866 x 1.811				
29,0 x 71,0	1.141 x 2.795				
35,0 x 65,0	1.377 x 2.559				
35,0 x 86,0	1.377 x 3.385				
35,0 x 112,0	1.377 x 4.409				
36,0 x 46,0	1.417 x 1.811				
37,0 x 54,0	1.456 x 2.125				
37,0 x 67,0	1.456 x 2.637				
37,0 x 88,0	1.456 x 3.464				
37,0 x 104,0	1.456 x 4.094	1,5	2,0	26,5	RD29X71
37,0 x 115,0	1.456 x 4.527				
46,0 x 54,0	1.811 x 2.126				
46,0 x 72,0	1.811 x 2.835				
46,0 x 92,0	1.811 x 3.622				
46,0 x 107,0	1.811 x 4.212				
50,0 x 98,0	1.968 x 3.858				
67,0 x 126,0	2.637 x 4.960				
72,0 x 136,0	2.834 x 5.354				
72,0 x 136,0	2.834 x 5.354				

Stainless Steel = Rm= 700 N/mm² - Mild Steel = Rm= 500 N/mm²

Use of non-Cembre punching accessories

Type	Punch & Die	Pilot hole Ø mm
TRD-9.4C (*)	GREENLEE 3/8" - 24 UNF	Ø 10.0
TRD-M11C (*)	BM, COSMEC (M11x1.5)	Ø 11.5
TD-M16C	BM, COSMEC (M16x1.5)	Ø 16.5
TD-27	BM, COSMEC (Ø105=Ø140)	Ø 27.5
TD-14X14-M14	BM, COSMEC 46x46	Ø 18.8
TD-120X20-M20	BM, COSMEC 92x92	Ø 27.5
TD-20X20-M20 (with plug)	BM, COSMEC 42x95	Ø 27.5
TGD-13.5X13.5-M13	BM, COSMEC 40x40; 45x45; 46x46 (M13)	Ø 18.8
TGD-10X10-M9	BM, COSMEC 006505	Ø 13.8
TD-9	IMB 9601	Ø 9.5
TD-16	IMB 9603	Ø 16.5
TD-10X10-M10 (with plug)	IMB 9623	Ø 14.5
TD-14X14-M14/1"	IMB 9625	Ø 19.5
TD-20 (without plug)	IMB 9626	Ø 27.5
TD-20X20-M20-C (with plug)	IMB 9626	Ø 27.5

(*) The washer supplied with the KIT must be threaded onto the draw stud and positioned between the head and the die to allow the die to rest correctly

general features



RHTD270	
Suitable for splitting nuts mm	16(M10)=27(M18)
Max operating pressure bar	700
Weight kg	1,76

Hydraulic nut splitting head complete with automatic quick coupler. For operating the head must be joined to a hydraulic pump developing a pressure of 700 bar (see page 218-224).



RHTD3241	
Suitable for splitting nuts mm	27(M18)=41(M27)
Max operating pressure bar	700
Weight kg	4,6

RHTD410T	
Suitable for splitting nuts mm	27(M18)=41(M27)
Max operating pressure bar	700
Weight kg	4,9

STORAGE	
Type	VAL-P4
Dimensions mm L x W x H	315 x 300 x 95
Weight kg	0,93
Supplied with the tool	✓

	RHTD270	RHTD3241	RHTD410T
A	40,5	66	77
B	25	36	41
C	105,5	208	222
D	54	75,5	75,5
E	7,5	16	21,5

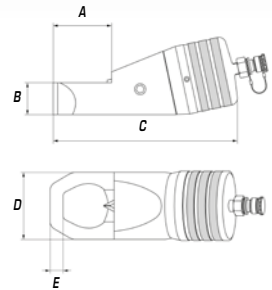

Application range

Type	HEXAGONAL NUTS		SQUARE NUTS	
	mm	Ø	mm	Ø
RHTD270 B-TD270	16	M 10	17	M 10
	17	M 10	19	M 12
	18	M 12	22	M 14
	19	M 12	24	M 16
	21	M 14	27	M 18
	22	M 14		
	24	M 16		
	27	M 18	27	M 18
RHTD3241 RHTD410T B-TD410T	27	M 18	27	M 18
	30	M 20	30	M 20
	32	M 22	32	M 22
	34	M 22	34	M 24
	36	M 24	36	M 27
	41	M 27		

B-TD270

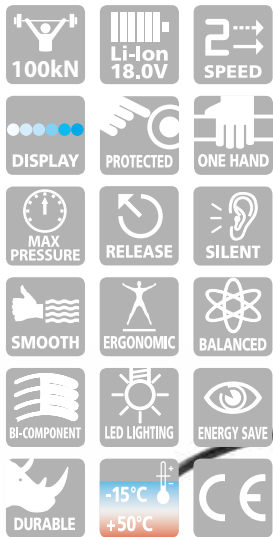

B-TD270	
Crimping force kN	100
Dimensions mm	
Length (with tube and head)	1.292,5
Height	350
Depth	83
Battery	18.0V 5.2Ah
Weight kg (with battery)	5,5

18.0 V battery operated hydraulic tool suitable for splitting fastening tools bushes, hexagonal and square nuts as per RHTD1724.



STORAGE	
Type	CVB-030
Dimensions mm L x W x H	497 x 266 x 455
Weight kg	1,4
Supplied with the tool	✓



B-TD410T

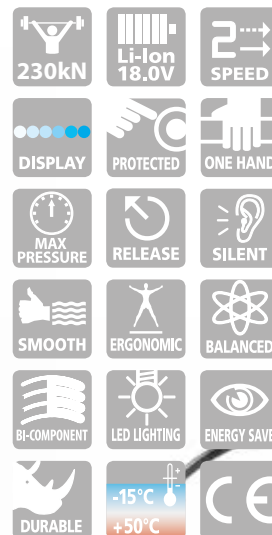

B-TD410T	
Crimping force kN	230
Dimensions mm	
Length (with tube and head)	1.360
Height	350
Depth	83
Battery	18.0V 5.2Ah
Weight kg (with battery)	8,8

18.0 V battery operated hydraulic tool suitable for splitting fastening bushes, hexagonal and square nuts as per RHTD410T.





CORDLESS HYDRAULIC TOOLS

symbol description

cordless hydraulic tools

	Crimping force kN		Equipped with safety valve as a additional safety element for the operator
	18.0V Li-Ion high power batteries		Provided with a maximum pressure sensor that allows to check the correct execution of the compressions or the limit switch control of the blades
	Double speed action: a rapid approach speed and a slower more powerful speed for crimping or cutting		Pressure release button
	Openable compression head, ideal for derivations from running conductors		Extremely quiet in operation
	Openable cutting head, ideal for cutting running cables		Very little vibration
	Tool with a large 42 mm jaw opening, for easier introduction/ removal of large size compression terminations and joints		Ergonomically designed with a sculptured body for operator comfort
	blades manufactured from high strength special Steel, heat treated to ensure a long service life		Lightweight and balanced tool for greater control
	Max cutting diameter		LED lighting of the working area
	Max hole punching diameter		Dual-compound plastic body Greater safety and comfort in handling, thanks to the rubber inserts
	The head can rotate to enable the operator to work in the most comfortable position		Ensures optimal use of energy available
	OLED display with multi-function capacitive touch button: Crimping force being generated, Battery power availability, Tool identification, LED state, Reset, No. of operational and service crimping cycles, Tool service required		Durable moulded body offering high resistance to wear and damage in all operating conditions
	Battery condition displayed to show the residual battery power		Crimping cycle data (up to 200,000 events) is automatically stored on a memory card for transfer to PC by USB interface
	Switch protected against accidental operation		Operating temperature range between -15 and +50°C
	Can be operated with one hand		

symbol description

cordless hydraulic tools



Hexagonal crimp



Radial crimp



Indent crimp



Deep indent crimp



"W" crimp



Oval crimp



Trapezium crimp



Circular crimp



Max operating pressure



Manual pressure release button



Fitted with an integral socket, for connection to a 12 V dc external power supply



Contains isolated oil



Hydraulic units provide protection against short circuit when accidentally cutting live L.V. / M.V. cables with nominal voltage up to 60 kV



CE marking



"Bilinear" configuration
Cembre bilinear tools have their mechanical centre of gravity nearest to the operator's wrist to optimise the overall ergonomics of the tool and provide a wider support for the hand



"Pistol" configuration
The new design and mass distribution favour the easy handling during use



"Standard" configuration
The design allows the maximum stability and comfort in handling and ergonomics



Smart Release Technology
Automatic retraction of the ram only occurs when the operator releases the start button, this allows visual verification of the die to ensure that they have fully met prior to releasing



Electronic Pressure Sensor
The EPS guarantees the precision of the crimping operation, checking the actual value of pressure and informing the operator of possible errors



Electronic Cut Sensor
The ECS guarantees the precision of the cutting operation, checking the complete stroke of the blades and informing the operator about possible errors.



Safe Cut Technology
Fitted with LED indicators and a buzzer to communicate during progress and at the completion of the cutting operation.



Radio Remote Control
Radio control device to utility cable cutting operations in limited access locations, eg. in man-holes, to enable working from a safe distance.



Data recording and intelligent control allow complete verification of operational parameters. SMARTOOL technology enables the user to store data from up to 200,000 cycles on the integrated memory card for transfer to a computer via a USB cable

18.0 V - 5.2 Ah CORDLESS TOOL FEATURES

general features

- 1 Head rotates through 180°
- 2 Switch protected against accidental operation
- 3 Pressure release button
- 4 Slot-in battery with release button
- 5 LED lighting of the working area
- 6 Motor ventilation
- 7 Bi-component body for increased impact resistance
- 8 Multifunction OLED display with touch button
- 9 Improved balance for better handling
- 10 Anatomically shaped grip for greater comfort
- 11 18.0V - 5.2 Ah Li-Ion high power batteries
- 12 SMARTOOL technology for viewing and downloading operational data



SUPPLIED WITH

- 1 CB1852L, 18.0V - 5.2 Ah Li-Ion high power battery (2 pcs.)
 - 2 ASC 30-36 EU 27044000 Battery charger (INPUT 220-240 V / 50-60 Hz; OUTPUT 12-42 V DC / 3.0 A max.)
 - 3 USB cable
 - 4 Shoulder strap
- Plastic or Metal carrying case



Multifunction OLED display:

LED ON

15
34985
General operating information

BATTERY
Battery power availability

P_m = 692 bar
OK
Pressure level check

F_m = 125.2 kN
OK
Crimping force check



18.0 V - 2.0 Ah CORDLESS TOOL FEATURES

general features

- 1 Bilinear mechanical design
- 2 Smart Release system to automatically retract the ram at the end of the crimping cycle
- 3 OLED multifunctional display with touch button
- 4 Electronic Pressure Sensor (EPS)
- 5 SMARTOOL technology for viewing and downloading operational data
- 6 Illumination of working area via 4 x LED lights
- 7 Bi-component plastic body
- 8 Head rotates for ease of operation in confined spaces
- 9 Switch protected against accidental operation
- 10 Pressure release button
- 11 Slot-in battery with release button
- 12 Battery condition displayed to show the residual battery power
- 13 Motor ventilation
- 14 The tools are fitted with a maximum pressure valve to indicate a correct crimping operation or the full extent of the ram travel
- 15 Can be operated with one hand
- 16 Extremely quiet in operation with very little vibration
- 17 Anatomically shaped grip for greater comfort
- 18 18.0 V - 2.0 Ah Li-Ion high power batteries



New Range *nd*



B15MD



SUPPLIED WITH

- 1 CB1820L, 18.0 V - 2.0 Ah Li-Ion high power battery (2 pcs.)
- 2 ASC30-36 EU 27044000 Battery charger (INPUT 220-240 V / 50-60 Hz; OUTPUT 12-42 V DC / 3.0 A max.)
- 3 USB cable (not for B15MD)

- Wrist strap
- Plastic carrying case



B15MD

18.0 V CORDLESS HYDRAULIC CRIMPING TOOL

general features

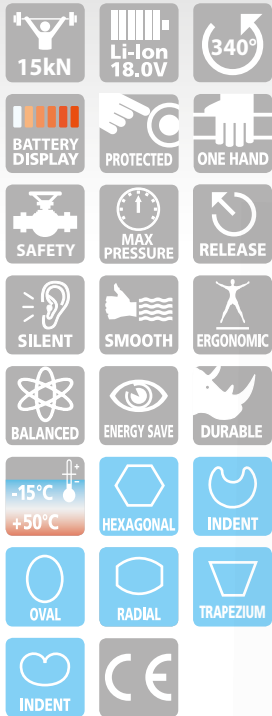

MAIN APPLICATIONS - max section sqmm

Section sqmm	0,25÷1,5	1,5÷2,5	4÷6	10	16	25	35	50	70	95	120	150	185	240	300	400	500	630	800	1000	
Copper lugs and splices																					
Insulated terminals																					
End sleeves																					

These tools are supplied without dies. For die selection, please refer to chart on pages 248 to 262



TECHNICAL FEATURES

Crimping force kN	15
Dimensions mm	
Length	337
Height	133
Width	81
Battery	18.0V 2.0Ah
Weight kg (with Battery)	1,74

STORAGE

Type	VAL-P22
Dimensions mm L x W x H	465 x 315 x 116
Weight kg	1,5
Supplied with the tool	✓
Purchase separately	-

The tool is supplied as:

- Basic tool with battery and wrist strap
- Spare battery
- Battery charger
- Plastic carrying case suitable for storing the tool and accessories



Many different interchangeable crimping dies available

Conductor Size sqmm (AWG)		Connector Type	Die Set	
0,25 ÷ 16	22 ÷ 6	A...; L...-M; L...-P; S...; RN...; BN...; GN...	MA03/3-15	☺
1,5 ÷ 10	16 ÷ 8	A...; L...-M; L...-P	ME03/2-15	
10 ÷ 16	8 ÷ 6	A...; 2A...; L...-M; L...-P	ME2/3-15	
4 ÷ 10	12 ÷ 8	T... (NF C 20130 style); L...-T	MS4/10-15	⬡
10 ÷ 16	8 ÷ 6	T... (NF C 20130 style); L...-T	MS10/16-15	
10 ÷ 16	8 ÷ 6	HR...; HSV...	MH10/16-15	⬡
6 ÷ 16	10 ÷ 6	DR... (DIN 46235 style); DSV... (DIN 46267 T1 style)	MK5/8-15	
10 ÷ 16	8 ÷ 6	ANE...; AN...; IN...; EN...	NN4-15	☺
0,25 ÷ 6	22 ÷ 10	R...; B...; G...; PL...; NL...	RBG-15	○
0,25 ÷ 6	22 ÷ 10	R...; B...; G... (not suffix P, RF/BF-BF)	RBV-15 with positioner	
0,3 ÷ 4	22 ÷ 12	PKE; PKC; PKD; PKT; KE	KE4-15	⬡
4 ÷ 16	12 ÷ 6	PKE; PKC; PKD; PKT; KE	KE16-15	
16 ÷ 35	6 ÷ 2	PKE; PKC; PKD; PKT; KE	KE35-15	
2,5 - 4 - 6	14 - 12 - 10	CS4 (for photovoltaic systems)	MCS4-15	☺

Can be operated with one hand. Balanced for greater control. Head rotates by 340° for ease of operation in confined spaces. The tool is fitted with a maximum pressure valve. Extremely quiet, minimal vibration. Durable moulded body offering high resistance to wear and damage in all operating conditions. Equipped with Li-Ion 18.0V - 2.0Ah rechargeable high capacity batteries.

The battery is equipped with LED indicators to show the remaining battery life at any time by pressing the adjacent button. Supplied in a robust plastic case to accommodate the tool and all the accessories. Two batteries and charger included. Many different interchangeable crimping dies available. Operating temperature: -15 to +50 °C



Battery condition display



Interchangeable die sets



Ergonomically designed operating switch



Automatic slot-in battery

18.0 V CORDLESS HYDRAULIC CRIMPING TOOL

B450ND-BV

general features

MAIN APPLICATIONS - max section sqmm

Section sqmm	0.25-1.5	1.5-2.5	4-6	10	16	25	35	50	70	95	120	150	185	240	300	400	500	600	800	1000	
L.V. lugs and splices																					
"C" sleeve Connectors																					

These tools are supplied without dies. For die selection, please refer to chart on pages 248 to 262

STORAGE

Type	VAL-P22
Dimensions mm L x W x H	465 x 315 x 116
Weight kg	1,5
Supplied with the tool	✓
Purchase separately	-

TECHNICAL FEATURES

Crimping force kN	50
Dimensions mm	
Length	364
Height	136
Width	81
Battery	18.0V 2.0Ah
Weight kg (with Battery)	2,6



The tool is supplied as:

- Basic tool with battery and wrist strap
- Battery charger
- USB cable
- Plastic carrying case suitable for storing the tool and accessories

B450ND-BV is a new generation of hand-held cordless tools, characterised by a "Bilinear" mechanical design.

B450ND-BV is suitable for crimping electrical connectors onto conductor cross sections up to 150 mm² and uses the die sets common to all Cembre 45 kN tools and heads. Equipped with Li-Ion 18.0V - 2.0Ah rechargeable high capacity batteries. The battery is equipped with LED indicators to show the remaining battery life at any time by pressing the adjacent button. The tool is fitted with a maximum pressure valve.

Wide-opening head, ideal for derivations from running conductors



4 LED lighting of the working area



Manual pressure release button



Battery connection system with release button



Sculptured body for optimum comfort



working hours at which ordinary maintenance is recommended. It is also a feature that the operating data is stored on a memory card for transfer to PC by USB interface. (SMARTOOL technology).

Weight and balance have been re-configured to yield improvements in handling and convenience.

The more rigid structure of the bi-component plastic body provides greater mechanical protection while its rubber inserts boost operator safety and comfort.

Quieter operation, illumination of the working area via LED lights and a minimum of vibration enhance the tool's practicality.

Flashing work lights and a continuous beep indicate to the operator that B450ND-BV has reached the



"Bilinear" mechanical design

B500ND

B500ND is the first of a new generation of hand-held cordless tools, characterised by a "Bilinear" mechanical design. Equipped with a Smart Release system which automatically retracts the ram at the end of the operating cycle. B500ND is suitable for crimping electrical connectors onto conductor cross sections up to 300 mm² and uses the die sets common to all Cembre 50kN tools and heads. Equipped with Li-Ion 18.0V - 2.0Ah rechargeable high capacity batteries.

18.0 V CORDLESS HYDRAULIC CRIMPING TOOL

general features

MAIN APPLICATIONS - max section sqmm

Section sqmm	0.25÷1.5	1.5÷2.5	4÷6	10	16	25	35	50	70	95	120	150	185	200	240	300	400	500	630	800	1000	
L.V. lugs and splices																						
Insulated terminals																						
End sleeves																						
"C" sleeve Connectors																						
H.V. lugs and splices																						

These tools are supplied without dies. For die selection, please refer to chart on pages 248 to 262



TECHNICAL FEATURES

Crimping force kN	60
Dimensions mm	
Length	396
Height	136
Width	81
Battery	18.0V 2.0Ah
Weight kg (with Battery)	3,15

STORAGE

Type	VAL-P22
Dimensions mm L x W x H	465 x 315 x 116
Weight kg	1,5
Supplied with the tool	✓
Purchase separately	-

The tool is supplied as:

- Basic tool with battery and wrist strap
- Spare battery
- Battery charger
- USB cable
- Plastic carrying case suitable for storing the tool and accessories



- general operating information
- the number of work cycles completed and remaining before recommended maintenance.



"Bilinear" mechanical design

KIT-B500ND-1

B500ND COMPRESSION KIT

general features

The kit includes B500ND cordless hydraulic crimping tool (60 kN) complete with 8 die sets (from 25 to 185 mm²) and a practical and sturdy carrying case for the tool and its accessories.

The tool is supplied as:

- Basic tool with battery and wrist strap
- Spare battery
- Battery charger
- USB cable
- Plastic carrying case suitable for storing the tool and accessories



KIT-B500ND-1

Kit includes:

- B500ND cordless hydraulic tool
- VALP22 plastic carrying case with accessories

8 die sets:

- ME5-50
- ME7-50
- ME10-50
- ME14-50
- ME19-50
- ME24-50
- ME30-50
- ME37-50

Hexagonal crimp for low voltage terminals and through connectors from 25 to 185 mm² A-M family

18.0 V CORDLESS HYDRAULIC CRIMPING TOOL

B540ND6

general features

MAIN APPLICATIONS - max section AWG

- Copper lugs and splices 300 MCM
- Aluminium lugs and splices 4/0
- Aluminium H taps 4/0 - 4/0

TECHNICAL FEATURES

Crimping force kN	54
Dimensions mm	
Length	495
Height	145
width	88
Battery	18.0V 2.0Ah
Weight kg (with Battery and CDD6N)	3,4

The professional tool ideal for OH lines and residential service applications.

STORAGE

Type	VAL-P60
Dimensions mm L x W x H	620 x 360 x 138
Weight kg	2,4
Supplied with the tool	✓
Purchase separately	-

The tool is supplied as:

- Basic tool with jaws CDD6N, battery and wrist strap
- Spare battery
- Battery charger
- USB cable
- Plastic carrying case suitable for storing the tool and accessories



B540ND6 is the first of a new generation of hand-held cordless tools, characterised by a "Bilinear" mechanical structure. Equipped with intelligent auto-return at the end of the operating cycle (Smart Release). Equipped with Li-Ion 18.0V - 2.0Ah rechargeable high capacity batteries. Jaws rotate by 180° for ease of operation in confined spaces.

Interchangeable Jaws

Many different Cembre interchangeable crimping and cutting jaws are available upon request.

CDD6N jaws



CMB4N jaws



CDD6-6N jaws



CMB5N jaws



CDD6-8N jaws



CMB6N jaws



54kN	Li-Ion 18.0V	SPEED
HEAD OPENING	180°	OLED
BATTERY DISPLAY	PROTECTED	ONE HAND
SAFETY	RELEASE	SILENT
SMOOTH	ERGONOMIC	BALANCED
LED LIGHTING	BI-COMPONENT	ENERGY SAVE
DURABLE	200k	-15°C +50°C
HEXAGONAL	RADIAL	INDENT
OVAL	INDENT	CIRCULAR
CE		

Fitted with a maximum pressure sensor for enhanced precision and repeatability of the maximum pressure cycle, and a pressure relief valve providing additional safety for the operator. The EPS guarantees the precision of the crimping operation, checking the actual value of pressure and informing the operator about possible errors (EPS).

The OLED display provides essential real time operating data, including:

- crimping force generated, thus verifying accordance with best practice
- battery charge status
- general operating information
- the number of work cycles completed and remaining before recommended maintenance.

Weight and balance have been re-configured to yield advances in handling and convenience.

The more rigid structure of the bi-component plastic body provides greater mechanical protection while its rubber inserts boost operator safety and comfort.

Quieter operation, illumination of the working area via LED lights and a minimum of vibration make for even more practical use. The integrated memory card enables the user to store data from up to 200,000 compression cycles for transfer to a computer via a USB communication interface. (SMARTOOL technology).

INTERCHANGEABLE CRIMPING AND CUTTING JAWS

CAT. No	GROOVES	CRIMPING DIE COMPATIBILITY	
CDD6N	"D3" TO ACCEPT ALL "W" STYLE CRIMPING DIES + "BG" FIXED GROOVE	FCI Burndy	W, X Series
		Greenlee	KD6 Series
		IlSCO	ND Series
		Huskie	HT-58 Series
CDD6-6N	"D3" TO ACCEPT ALL "W" STYLE CRIMPING DIES	Panduit	CD-2001 series
		FCI Burndy	W, X Series
		Greenlee	KD6 Series
		IlSCO	ND Series
CDD6-8N	"D3" TO ACCEPT ALL "W" STYLE CRIMPING DIES + "O" FIXED GROOVE	Huskie	HT-58 Series
		Panduit	CD-2001 series
		FCI Burndy	W, X Series
		Greenlee	KD6 Series
CMB4N	Cutting jaws for underground: Aluminum & Copper stranded cables. Max opening 32 mm	IlSCO	ND Series
		Huskie	HT-58 Series
		Panduit	CD-2001 series
CMB5N	Cutting jaws for OHL: up to 200 mm ² ACSR and BLX cable		
CMB6N	Cutting jaws for guy wires: Up to Ø 10 mm galvanised steel wire (<1250N/mm ²)		

B500

18.0 V CORDLESS HYDRAULIC CRIMPING TOOL

general features



MAIN APPLICATIONS - max section sqmm

Section sqmm	0.25+-1.5	1.5+-2.5	4-6	10	16	25	35	50	70	95	120	150	185	200	240	300	400	500	630	800	1000	
L.V. lugs and splices																						
Insulated terminals																						
End sleeves																						
"C" sleeve Connectors																						
H.V. lugs and splices																						

These tools are supplied without dies. For die selection, please refer to chart on pages 248 to 262



TECHNICAL FEATURES

Crimping force kN	63
Dimensions mm	
Length	300
Height	343
Width	83
Battery	18.0V 5.2Ah
Weight kg (with Battery)	4,2

STORAGE

Type	VAL-P38
Dimensions mm L x W x H	520 x 432 x 126
Weight kg	2,6
Supplied with the tool	✓
Purchase separately	-

The 63 kN B500 is suitable for a wide range of connectors up to 300 sqmm using die sets common to the Cembre 50 kN tooling range.

Equipped with Li-Ion 18.0V - 5.2Ah rechargeable high capacity batteries.

The OLED display provides essential real time tool operating information data including:

- Crimping pressure and force being generated, for confirmation of adherence to norms and best practice
- Battery power availability
- Tool identification, LED work light state, reset, no. of operational and service crimping cycles
- Tool service required to maintain optimum condition.

The tool is supplied as:

- Basic tool with battery and shoulder strap
- Spare battery
- Battery charger
- USB cable
- Plastic carrying case suitable for storing the tool and 14 die sets



B500-KV version also available for Power Supply Companies



LED lighting of the working area



Multifunction OLED display with touch button



Anatomically shaped grip for improved comfort



Slot-in battery with release button

B500 COMPRESSION KIT

general features



KIT-B500-1 KIT-B500-2 KIT-B500-MK



KIT-B500-MK

Kit includes:

B500 cordless hydraulic tool

VAL-P38 plastic carrying case with accessories

10 die sets:

MK8-50

MK10-50

MK14-50

MK16-50

MK18-50

MK20-50

MK22-50

MK25-50

MK28-50

Hexagonal crimp
for low voltage
terminals and through connectors
from 16 to 240 mm²
DIN 46235 family

KIT-B500-1

Kit includes:

B500 cordless hydraulic tool

VAL-P38 plastic carrying case with accessories

8 die sets:

ME5-50

ME7-50

ME10-50

ME14-50

ME19-50

ME24-50

ME30-50

ME37-50

Hexagonal crimp
for low voltage
terminals and through connectors
from 25 to 185 mm²
A-M family

KIT-B500-2

Kit includes:

B500 cordless hydraulic tool

VAL-P38 plastic carrying case with accessories

6 die sets:

Nest Indentor

MA5-50 PA5-50

MA7-50 PA10-50

MA10-50 PA19-50

MA14-50 PA19-50

MA19-50 PA24-50

MA24-50 PA24-50

Indent crimp
for low voltage general purpose
terminals and through
connectors from
25 to 120 mm²

B550

18.0 V CORDLESS HYDRAULIC CRIMPING TOOL

general features

MAIN APPLICATIONS - max section sqmm

Section sqmm	0.25-1.5	1.5-2.5	4-6	10	16	25	35	50	70	95	120	150	185	200	240	300	400	500	630	800	1000	
L.V. lugs and splices																						
Insulated terminals																						
End sleeves																						
"C" sleeve Connectors																						
H.V. lugs and splices																						

These tools are supplied without dies. For die selection, please refer to chart on pages 248 to 262

- 132kN
- Li-Ion 18.0V
- SPEED
- 180°
- OLED
- BATTERY DISPLAY
- PROTECTED
- ONE HAND
- SAFETY
- RELEASE
- SILENT
- SMOOTH
- ERGONOMIC
- BALANCED
- LED LIGHTING
- BI-COMPONENT
- ENERGY SAVE
- DURABLE
- 200k
- 15°C
- +50°C
- HEXAGONAL
- RADIAL
- INDENT
- OVAL
- INDENT
- CIRCULAR
- CE



TECHNICAL FEATURES

Crimping force kN	57.7
Dimensions mm	
Length	359
Height	358
Width	83
Battery	18.0V 5.2Ah
Weight kg (with Battery)	5,3

STORAGE

Type	VAL-P40
Dimensions mm L x W x H	520 x 432 x 126
Weight kg	2,6
Supplied with the tool	✓
Purchase separately	-

The tool is supplied as:

- Basic tool with battery and shoulder strap
- Spare battery
- Battery charger
- USB cable
- Plastic carrying case suitable for storing the tool and accessories



The next generation of Cembre cordless hydraulic tools represents a significantly advantageous evolution from current models.

The B550, with adapter AU55-50, will accept all Cembre 50 kN dies; with adapter AU55-W it will accept "W" dies.

Equipped with Li-Ion 18.0V - 5.2Ah rechargeable high capacity batteries.

The OLED display provides essential real time tool operating information data including:

- Crimping pressure and force being generated, for confirmation of adherence to norms and best practice
- Battery power availability
- Tool identification, LED work light state, reset, no. of operational and service crimping cycles
- Tool service required to maintain optimum condition.

With adapter AU55-50 for accepting Cembre dies.

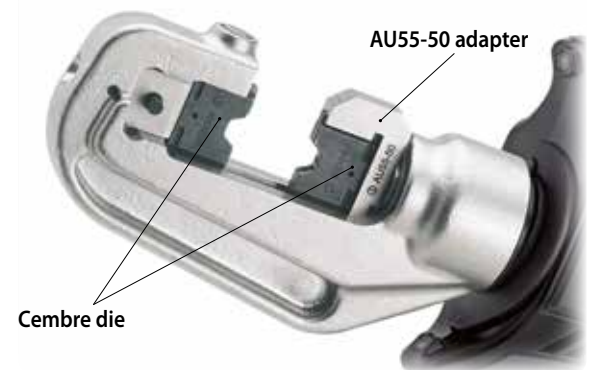

With adapter AU55-W for accepting "W" dies.

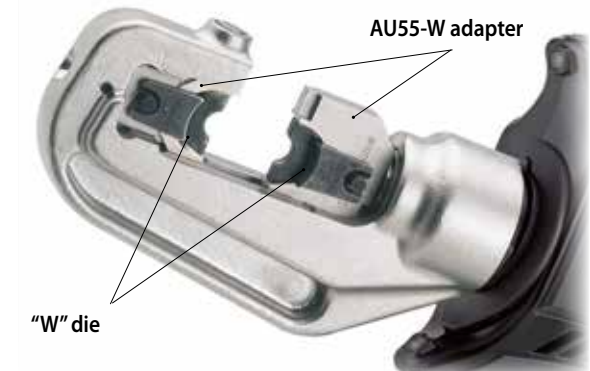

B550-KV version also available for Power Supply Companies

18.0 V CORDLESS HYDRAULIC CRIMPING TOOL

B600

general features

MAIN APPLICATIONS - max section sqmm

Section sqmm	0.25-1.5	1.5-2.5	4-6	10	16	25	35	50	70	95	100	120	150	185	200	240	300	400	500	680	800	1000	
L.V. lugs and splices																							
Insulated terminals																							
"C" sleeve Connectors																							
H.V. lugs and splices																							

These tools are supplied without dies. For die selection, please refer to chart on pages 248 to 262

TECHNICAL FEATURES

Crimping force kN	68
Dimensions mm	
Length	347
Height	344
Width	83
Battery	18.0V 5.2Ah
Weight kg (with Battery)	5,1

STORAGE

Type	VAL-P40
Dimensions mm L x W x H	520 x 432 x 126
Weight kg	2,6
Supplied with the tool	✓
Purchase separately	-



B600 is suitable for installing crimp type electrical connectors on copper cables up to 240 sqmm.

Die set common to 50 kN Cembre tools (e.g. HT51, RH50) can be used in this tool only with Spring code 6522051, purchased separately.

Equipped with Li-Ion 18.0V - 5.2Ah rechargeable high capacity batteries.

The OLED display provides essential real time tool operating information data including:

- Crimping pressure and force being generated, for confirmation of adherence to norms and best practice
- Battery power availability
- Tool identification, LED work light state, reset, no. of operational and service crimping cycles
- Tool service required to maintain optimum condition.

In addition to a comprehensive range of dies, is also possible to use dies from other manufacturers type Gr.1.

The tool is supplied as:

- Basic tool with battery and shoulder strap
- Spare battery
- Battery charger
- USB cable
- Plastic carrying case suitable for storing the tool and accessories



Multifunction OLED display with touch button



Anatomically shaped grip for improved comfort



Slot-in battery with release button

B1350-C

18.0 V CORDLESS HYDRAULIC CRIMPING TOOL

general features



MAIN APPLICATIONS - max section sqmm

Section sqmm	0.25+-1.5	1.5+-2.5	4-6	10	16	25	35	50	70	95	120	150	185	200	240	300	400	500	630	800	1000	
L.V. lugs and splices																						
Insulated terminals																						
"C" sleeve Connectors																						
H.V. lugs																						
H.V. Splices*																						

*limited to the cable insulation diameter

These tools are supplied without dies. For die selection, please refer to chart on pages 248 to 262



TECHNICAL FEATURES

Crimping force kN	132
Dimensions mm	
Length	338
Height	344
Width	83
Jaw Opening mm	25
Battery	18.0V 5.2Ah
Weight kg (with Battery)	6,5

STORAGE

Type	VAL-P39
Dimensions mm L x W x H	520 x 432 x 126
Weight kg	2,6
Supplied with the tool	✓
Purchase separately	-

B1350-C is suitable for a wide range of connectors up to 400 sqmm using die sets common to the Cembre 130 kN tooling range.

Equipped with Li-Ion 18.0V - 5.2Ah rechargeable high capacity batteries. The OLED display provides essential real time tool operating information data including:

- Crimping pressure and force being generated, for confirmation of adherence to norms and best practice
- Battery power availability
- Tool identification, LED work light state, reset, no. of operational and service crimping cycles
- Tool service required to maintain optimum condition.

The tool is supplied as:

- Basic tool with battery and shoulder strap
- Spare battery
- Battery charger
- USB cable
- Plastic carrying case suitable for storing the tool and 8 die sets



B1350-C-KV version also available for Power Supply Companies



LED lighting of the working area



Multifunction OLED display with touch button



Anatomically shaped grip for improved comfort



Slot-in battery with release button

18.0 V CORDLESS HYDRAULIC CRIMPING TOOL

B1350L-C

general features

MAIN APPLICATIONS - max section sqmm

Section sqmm	0.25±1.5	1.5±2.5	4-6	10	16	25	35	50	70	95	120	150	185	200	240	300	400	500	630	800	1000	
L.V. lugs and splices																						
Insulated terminals																						
"C" sleeve Connectors																						
H.V. lugs and splices																						

These tools are supplied without dies. For die selection, please refer to chart on pages 248 to 262

TECHNICAL FEATURES

Crimping force kN	132
Dimensions mm	
Length	395
Height	372
Width	83
Jaw Opening mm	42
Battery	18.0V 5.2Ah
Weight kg (with Battery)	8,1

STORAGE

Type	VAL-P39
Dimensions mm L x W x H	520 x 432 x 126
Weight kg	2,6
Supplied with the tool	✓
Purchase separately	-



B1350L-C-KV version also available for Power Supply Companies



The tool is supplied as:

- Basic tool with battery and shoulder strap
- Spare battery
- Battery charger
- USB cable
- Plastic carrying case suitable for storing the tool and 8 die sets

B1350L-C version, featuring a large 42 mm jaw opening, for an easier introduction/removal of large size compression terminations and joints.

B1350L-C is suitable for a wide range of connectors up to 400 sqmm using die sets common to the Cembre 130 kN tooling range.

Equipped with Li-Ion 18.0V - 5.2Ah rechargeable high capacity batteries. The OLED display provides essential real time tool operating information data including:

- Crimping pressure and force being generated, for confirmation of adherence to norms and best practice
- Battery power availability



- Tool identification, LED work light state, reset, no. of operational and service crimping cycles
- Tool service required to maintain optimum condition.

B1350-UC

18.0 V CORDLESS HYDRAULIC CRIMPING TOOL

general features



MAIN APPLICATIONS - max section sqmm

Section sqmm	0.25÷1.5	1.5÷2.5	4÷6	10	16	25	35	50	70	95	120	150	185	200	240	300	400	500	630	800	1000	
L.V. lugs and splices																						
Insulated terminals																						
"C" sleeve Connectors																						
Alu lugs and splices																						
H.V. lugs and splices																						

These tools are supplied without dies. For die selection, please refer to chart on pages 248 to 262



TECHNICAL FEATURES

Crimping force kN	132
Dimensions mm	
Length	351
Height	369
Width	83
Battery	18.0V 5.2Ah
Weight kg (with Battery)	6,3

STORAGE

Type	VAL-P39
Dimensions mm L x W x H	520 x 432 x 126
Weight kg	2,6
Supplied with the tool	✓
Purchase separately	-

B1350-UC will accept the accessories for performing the "Deep Stepped Indent" system of crimping on Aluminium cables.

The B1350-UC will accept all semi-circular slotted dies, common to most 12 tons tools (U dies).

Equipped with Li-Ion 18.0V - 5.2Ah rechargeable high capacity batteries.

The OLED display provides essential real time tool operating information data including:

- Crimping pressure and force being generated, for confirmation of adherence to norms and best practice
- Battery power availability
- Tool identification, LED work light state, reset, no. of operational and service crimping cycles
- Tool service required to maintain optimum condition.

The tool is supplied as:

- Basic tool with battery and shoulder strap
- Spare battery
- Battery charger
- USB cable
- Plastic carrying case suitable for storing the tool and 8 die sets



STORAGE

Type	VAL-130*
Dimensions mm L x W x H	360 x 280 x 48
Weight kg	3,0
Purchase separately	✓

*Suitable for the storage of accessories for crimping Aluminium connectors



VAL-130

18.0 V CORDLESS HYDRAULIC CRIMPING TOOL

B1300-C

general features

MAIN APPLICATIONS - max section sqmm

Section sqmm	0.25-1.5	1.5-2.5	4-6	10	16	25	35	50	70	95	120	150	185	200	240	300	400	500	630	800	1000	
L.V. lugs and splices																						
Insulated terminals																						
"C" sleeve Connectors																						
H.V. lugs																						
H.V. Splices*																						

*limited to the cable insulation diameter

These tools are supplied without dies. For die selection, please refer to chart on pages 248 to 262

TECHNICAL FEATURES

Crimping force kN	132
Dimensions mm	
Length	406
Height	239
Width	102,5
Jaw Opening mm	25
Battery	18.0V 5.2Ah
Weight kg (with Battery)	6,5

STORAGE

Type	VAL-P44
Dimensions mm L x W x H	680 x 473 x 151
Weight kg	3,7
Supplied with the tool	✓
Purchase separately	-

The tool is supplied as:

- Basic tool with battery and shoulder strap
- Spare battery
- Battery charger
- USB cable
- Plastic carrying case suitable for storing the tool and 12 die sets



B1300-C-KV version also available for Power Supply Companies

B1300-C is suitable for a wide range of connectors up to 400 sqmm using die sets common to the Cembre 130 kN tooling range. Equipped with Li-Ion 18.0V - 5.2Ah rechargeable high capacity batteries.

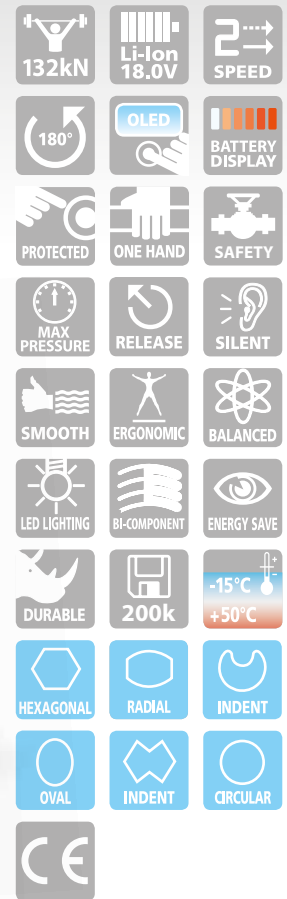

The OLED display provides essential real time tool operating information data including:

- Crimping pressure and force being generated, for confirmation of adherence to norms and best practice
- Battery power availability
- Tool identification, LED work light state, reset, no. of operational and service crimping cycles
- Tool service required to maintain optimum condition.

B1300-C COMPRESSION KIT

general features

KIT-B1300-C-1 KIT-B1300-C-2 KIT-B1300-C-MK

KIT-B1300-C-1

Kit includes:

- B1300-C cordless hydraulic tool
- VAL-P44 plastic carrying case with accessories

7 die sets:

ME10-C	Hexagonal crimp for low voltage terminals and through connectors from 50 to 240 mm ² A-M family
ME14-C	
ME19-C	
ME24-C	
ME30-C	
ME37-C	
ME48-C	

KIT-B1300-C-2

Kit includes:

- B1300-C cordless hydraulic tool
- VAL-P44 plastic carrying case with accessories

11 die sets:

Nest	Indentor	
MA2-C		Indent crimp for low voltage general purpose terminals and through connectors from 10 to 240 mm ²
MA3-C		
MA5-C	PA10-C	
MA7-C		
MA10-C		
MA14-C		
MA19-C	PA24-C	
MA24-C		
MA30-C		
MA37-C	PA48-C	
MA48-C		

KIT-B1300-C-MK

Kit includes:

- B1300-C cordless hydraulic tool
- VAL-P44 plastic carrying case with accessories

11 die sets:

MK6-C	Hexagonal crimp for low voltage terminals and through connectors from 10 to 240 mm ² DIN 46235 family
MK8-C	
MK10-C	
MK12-C	
MK14-C	
MK16-C	
MK18-C	
MK20-C	
MK22-C	
MK25-C	
MK28-C	

B1300L-C

18.0 V CORDLESS HYDRAULIC CRIMPING TOOL

general features



MAIN APPLICATIONS - max section sqmm

Section sqmm	0.25÷1.5	1.5÷2.5	4÷6	10	16	25	35	50	70	95	120	150	185	200	240	300	400	500	630	800	1000	
L.V. lugs and splices																						
Insulated terminals																						
"C" sleeve Connectors																						
H.V. lugs and splices																						

These tools are supplied without dies. For die selection, please refer to chart on pages 248 to 262

TECHNICAL FEATURES

Crimping force kN	132
Dimensions mm	
Length	471
Height	239
Width	102,5
Jaw Opening mm	42
Battery	18.0V 5.2Ah
Weight kg (with Battery)	8,0



STORAGE

Type	VAL-P44
Dimensions mm L x W x H	680 x 473 x 151
Weight kg	3,7
Supplied with the tool	✓
Purchase separately	-



The B1300L-C version, featuring a large 42 mm jaw opening, for an easier introduction/removal of large size compression terminations and joints.

B1300L-C is suitable for a wide range of connectors up to 400 sqmm using die sets common to the Cembre 130 kN tooling range. Equipped with Li-Ion 18.0V - 5.2Ah rechargeable high capacity batteries.

The OLED display provides essential real time tool operating information data including:

- Crimping pressure and force being generated, for confirmation of adherence to norms and best practice
- Battery power availability
- Tool identification, LED work light state, reset, no. of operational and service crimping cycles
- Tool service required to maintain optimum condition.



B1300L-C-KV version also available for Power Supply Companies

The tool is supplied as:

- Basic tool with battery and shoulder strap
- Spare battery
- Battery charger
- USB cable
- Plastic carrying case suitable for storing the tool and 12 die sets

18.0 V CORDLESS HYDRAULIC CRIMPING TOOL

B1300-UC

general features

MAIN APPLICATIONS - max section sqmm

Section sqmm	0.25-1.5	1.5-2.5	4-6	10	16	25	35	50	70	95	120	150	185	200	240	300	400	500	630	800	1000	
L.V. lugs and splices																						
Insulated terminals																						
"C" sleeve Connectors																						
Alu lugs and splices																						
H.V. lugs and splices																						

These tools are supplied without dies. For die selection, please refer to chart on pages 248 to 262

TECHNICAL FEATURES

Crimping force kN	132
Dimensions mm	
Length	423
Height	239
Width	102,5
Battery	18.0V 5.2Ah
Weight kg (with Battery)	6,5



STORAGE

Type	VAL-P44
Dimensions mm L x W x H	680 x 473 x 151
Weight kg	3,7
Supplied with the tool	✓
Purchase separately	-



The tool is supplied as:

- Basic tool with battery and shoulder strap
- Spare battery
- Battery charger
- USB cable
- Plastic carrying case suitable for storing the tool and 12 die sets

STORAGE

Type	VAL-130*
Dimensions mm L x W x H	360 x 280 x 48
Weight kg	3,0
Purchase separately	✓

*Suitable for the storage of accessories for crimping Aluminium connectors



VAL-130

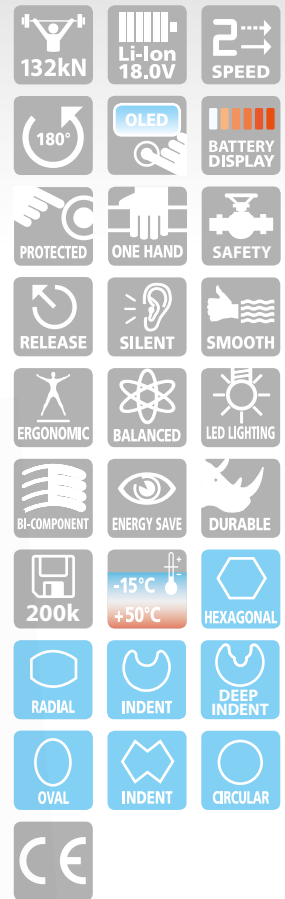

B1300-UC will accept the accessories for performing the "Deep Stepped Indent" system of crimping on Aluminium cables. The B1300-UC will accept all semi-circular slotted dies, common to most 12 tons tools (U dies).

Equipped with Li-Ion 18.0V - 5.2Ah rechargeable high capacity batteries.

The OLED display provides essential real time tool operating information data including:

- Crimping pressure and force being generated, for confirmation of adherence to norms and best practice
- Battery power availability
- Tool identification, LED work light state, reset, no. of operational and service crimping cycles
- Tool service required to maintain optimum condition.

B-TC250ND

18.0 V CORDLESS HYDRAULIC CUTTING TOOL

overhead line application

MAIN APPLICATIONS

specifically designed to cut Copper, aldrej, Aluminium, Aluminium-Steel cables and Steel ropes, Aluminium and Steel rods having Ø max 25 mm



TECHNICAL FEATURES

Max cutting Ø mm	25
Dimensions mm	
Length	401
Height	136
Width	81
Battery	18.0V 2.0Ah
Weight kg (with Battery)	3,5

STORAGE

Type	VAL-P22
Dimensions mm L x W x H	465 x 315 x 116
Weight kg	1,5
Supplied with the tool	✓
Purchase separately	-

The tool is supplied as:

- Basic tool with battery and wrist strap
- Spare battery
- Battery charger
- USB cable
- Plastic carrying case suitable for storing the tool and accessories



B-TC250ND is a new generation of hand-held cordless tools, characterised by a "Bilinear" mechanical design.

B-TC250ND is specifically designed to cut Copper, aldrej, Aluminium, Aluminium-Steel cables and Steel ropes, Aluminium and Steel rods having a max overall diameter of 25 mm.

The blades are manufactured from high strength special Steel, heat treated to ensure a long service life. New Li-Ion 18.0V - 2.0Ah batteries offer a higher capacity, while greater cutting speed and cutting force result from a revitalised hydraulic system with double speed action.

The battery is equipped with led indicators that indicate the remaining battery life at any time by pressing the adjacent button.

The head can rotate through 180 degrees, to enable the operator to work in the most comfortable position, and can easily be opened to allow cutting of running cables.

Fitted with a maximum hydraulic pressure valve.

Weight and balance have been re-configured to yield improvements in handling and convenience.

The more rigid structure of the bi-component plastic body provides greater mechanical protection while its rubber inserts boost operator safety and comfort.

Quieter operation, illumination of the working area via LED lights and a minimum of vibration enhance the tool's practicality.

Two batteries and charger included. Same charger of all our tools.

Operating temperature: -15 to +50 °C

CUTTING CAPACITY - a few examples

	MATERIAL	TENSILE STRENGTH (daN/mm ²)	MAX CUTTING DIAMETER (mm)
			B-TC250ND
ROPE & CONDUCTORS	COPPER	≤ 41	25
	ALUMINIUM	≤ 20	25
	ALMELEC	≤ 34	25
	STEEL	≤ 180	INDICATIVE EXAMPLES: 7 x 3,0 : Ø est. = 9,0 mm 19 x 2,1 : Ø est. = 10,5 mm 19 x 2,3 : Ø est. = 11,5 mm
	MULTI STRANDS STEEL (STRANDS Qty ≥ 200)	≤ 180	18
	ACSR	≤ 180	25 INDICATIVE EXAMPLES: 26 x 2,50 + 7 x 1,95 : Ø est. = 15,85 26 x 3,06 + 7 x 2,38 : Ø est. = 19,38 26 x 3,60 + 7 x 2,80 : Ø est. = 22,80
RODS	STEEL	≤ 60	13
		≤ 42	16
	COPPER	≤ 30	20
		≤ 25	23
ALUMINIUM	≤ 16	25	

18.0 V CORDLESS HYDRAULIC CUTTING TOOL

overhead line application

MAIN APPLICATIONS

specifically designed to cut Copper, aldrej, Aluminium, Aluminium-Steel cables and Steel ropes, Aluminium and Steel rods having Ø max 32 mm

STORAGE

Type	VAL-P48
Dimensions mm L x W x H	620 x 360 x 138
Weight kg	2,4
Supplied with the tool	✓
Purchase separately	-

TECHNICAL FEATURES

Max cutting Ø mm	32
Dimensions mm	
Length	444
Height	136
Width	81
Battery	18.0V 2.0Ah
Weight kg (with Battery)	3,95



The tool is supplied as:

- Basic tool with battery and wrist strap
- Spare battery
- Battery charger
- USB cable
- Plastic carrying case suitable for storing the tool and accessories



B-TC320ND



B-TC320ND is a new generation of hand-held cordless tools, characterised by a "Bilinear" mechanical design.

B-TC320ND is specifically designed to cut Copper, aldrej, Aluminium, Aluminium-Steel cables and Steel ropes, Aluminium and Steel rods having a max overall diameter of 32 mm.

The blades are manufactured from high strength special Steel, heat treated to ensure a long service life. New Li-Ion 18.0V - 2.0Ah batteries offer a higher capacity, while greater cutting speed and cutting force result from a revitalised hydraulic system with double speed action.

The battery is equipped with led indicators that indicate the remaining battery life at any time by pressing the adjacent button.

The head can rotate through 180 degrees, to enable the operator to work in the most comfortable position, and can easily be opened to allow cutting of running cables.

Fitted with a maximum hydraulic pressure valve.

Weight and balance have been re-configured to yield improvements in handling and convenience.

The more rigid structure of the bi-component plastic body provides greater mechanical protection while its rubber inserts boost operator safety and comfort. Quieter operation, illumination of the working area via LED lights and a minimum of vibration enhance the tool's practicality. Two batteries and charger included. Same charger of all our tools.

Operating temperature:

-15 to +50 °C

CUTTING CAPACITY - a few examples

Section mm ²	Ø mm	Stranding	Cable Type
120	13,3 mm	-	RIM120
50	8,9	7 x 2,95 mm	Bronze
70	10,3	19 x 2,06 mm	Bronze
95	12,5	19 x 2,50 mm	Bronze
70	10,7	19/2,14	Aluminium
95	12,5	19/2,5	Aluminium
150	15,75	37/2,25	Aluminium
323	23,25	19/4,65	Aluminium
415	-	37/3,78	Aluminium
35/6	8,1	6/2,70 + 1/2,70	Aluminium-steel
50/8	9,6	6/3,20 + 1/3,20	Aluminium-steel
50/30	11,7	12/2,33 + 7/2,33	Aluminium-steel
70/12	11,6	26/1,85 + 7/1,44	Aluminium-steel
95/15	13,4	26/2,15 + 7/1,67	Aluminium-steel
150/25	17,3	26/2,70 + 7/2,10	Aluminium-steel
170/40	18,95	30/2,79 + 7/2,79	Aluminium-steel
185/30	19,0	26/3,00 + 7/2,33	Aluminium-steel
230/30	21,0	24/3,5 + 7/2,33	Aluminium-steel
240/40	21,9	26/3,45 + 7/2,68	Aluminium-steel
495/35	29,9	45/3,74 + 7/2,49	Aluminium-steel
297,7 (OSPREY)	22,33	18/4,47 + 1/4,47	Aluminium-steel
327,9 (DOVE)	23,55	26/3,72 + 7/2,84	Aluminium-steel
239	20,1	37/2,87	Rope Aluminium Alloy
50	11,0	Class 5	Aluminium flex
95	18,5 mm	-	Steel flex
153	16,0	19/3,2	Cu
70	19,5	2214/0,2	Cu extra flex
16	9,0	126/0,4	Cu flex
120	19,9	608/0,5	Cu flex
240	-	1221/0,5	Cu flex

B-TC250

18.0 V CORDLESS HYDRAULIC CUTTING TOOL

overhead line application

MAIN APPLICATIONS

specifically designed to cut Copper, aldre, Aluminium, Aluminium-Steel cables and Steel ropes, Aluminium and Steel rods having Ø max 25 mm



TECHNICAL FEATURES

Max cutting Ø mm	25
Dimensions mm	
Length	300
Height	337
Width	83
Battery	18.0V 5.2Ah
Weight kg (with Battery)	4,65

STORAGE

Type	VAL-P40
Dimensions mm L x W x H	520 x 432 x 126
Weight kg	2,6
Supplied with the tool	✓
Purchase separately	-

The tool is supplied as:

- Basic tool with battery and shoulder strap
- Spare battery
- Battery charger
- USB cable
- Plastic carrying case suitable for storing the tool and accessories



Next generation of 18.0 V cordless hydraulic cutting tool specifically designed to cut Copper, aldre, Aluminium, Aluminium-Steel cables and Steel ropes, Aluminium and Steel rods having a max overall diameter of 25 mm.

The blades are manufactured from high strength special Steel, heat treated to ensure a long service life. New Li-Ion 18.0V - 5.2Ah batteries offer a higher capacity, while greater cutting speed and cutting force result from a revitalised hydraulic system with double speed action. The battery is equipped with LED indicators to show the remaining battery life at any time by pressing the adjacent button.

The head can rotate through 180 degrees, to enable the operator to work in the most comfortable position, and can easily be opened to allow cutting of running cables. Fitted with a maximum hydraulic pressure valve. Designed with improved balance, B-TC250 is easily manageable during the cutting process and, by the use of bi-component plastics, has a shell with high resistance to wear and damage. Rubber grip inserts, low noise and minimal vibration aid operator comfort while additional convenience and safety are provided by LED lighting of the working area. Operating temperature: -15 to +50 °C

CUTTING CAPACITY - a few examples

	MATERIAL	TENSILE STRENGTH (daN/mm ²)	MAX CUTTING DIAMETER (mm)
			B-TC250
ROPE & CONDUCTORS	COPPER	≤ 41	25
	ALUMINIUM	≤ 20	25
	ALMELEC	≤ 34	25
	STEEL	≤ 180	INDICATIVE EXAMPLES: 7 x 3,0 : Ø est. = 9,0 mm 19 x 2,1 : Ø est. = 10,5 mm 19 x 2,3 : Ø est. = 11,5 mm
	MULTI STRANDS STEEL (STRANDS Qty ≥ 200)	≤ 180	18
	ACSR	≤ 180	25 INDICATIVE EXAMPLES: 26 x 2,50 + 7 x 1,95 : Ø est. = 15,85 26 x 3,06 + 7 x 2,38 : Ø est. = 19,38 26 x 3,60 + 7 x 2,80 : Ø est. = 22,80
RODS	STEEL	≤ 60	13
		≤ 42	16
	COPPER	≤ 30	20
		≤ 25	23
	ALUMINIUM	≤ 16	25

18.0 V CORDLESS HYDRAULIC CUTTING TOOL

overhead line application

MAIN APPLICATIONS

specifically designed to cut Copper, aldrej, Aluminium, Aluminium-Steel cables and Steel ropes, Aluminium and Steel rods having Ø max 45 mm



TECHNICAL FEATURES

Max cutting Ø mm	45
Dimensions mm	
Length	407
Height	401
Width	88
Battery	18.0V 5.2Ah
Weight kg (with Battery)	6,7

STORAGE

Type	VAL-P40
Dimensions mm L x W x H	520 x 432 x 126
Weight kg	2,6
Supplied with the tool	✓
Purchase separately	-



The tool is supplied as:

- Basic tool with battery and shoulder strap
- Spare battery
- Battery charger
- USB cable
- Plastic carrying case suitable for storing the tool and accessories

CUTTING CAPACITY - a few examples

	MATERIAL	TENSILE STRENGTH (daN/mm ²)	MAX CUTTING DIAMETER (mm)
			B-TC450
ROPE & CONDUCTORS	COPPER	≤ 41	45
	ALUMINIUM	≤ 20	45
	ALMELEC	≤ 34	45
	STEEL	≤ 180	INDICATIVE EXAMPLES: 7 x 3,0 : Ø est. = 9,0 mm 19 x 2,1 : Ø est. = 10,5 mm 19 x 2,3 : Ø est. = 11,5 mm
	MULTI STRANDS STEEL (STRANDS Qty ≥ 200)	≤ 180	18
	ACSR	≤ 180	45 INDICATIVE EXAMPLES: 26 x 2,50 + 7 x 1,95 : Ø est. = 15,85 26 x 3,06 + 7 x 2,38 : Ø est. = 19,38 26 x 3,60 + 7 x 2,80 : Ø est. = 22,80 54 x 3,50 + 19 x 2,10 : Ø est. = 31,50 54 x 4,36 + 19 x 2,62 : Ø est. = 39,20
RODS	STEEL	≤ 60	18
		≤ 42	20
	COPPER	≤ 30	30
		≤ 25	32
	ALUMINIUM	≤ 16	45

Next generation of 18.0 V cordless hydraulic cutting tool specifically designed to cut Copper, aldrej, Aluminium, Aluminium-Steel cables and Steel ropes, Aluminium and Steel rods having a max overall diameter of 45 mm.

The blades are manufactured from high strength special Steel, heat treated to ensure a long service life. New Li-Ion 18.0V - 5.2Ah batteries offer a higher capacity, while greater cutting speed and cutting force result from a revitalised hydraulic system with double speed action.

The battery is equipped with LED indicators to show the remaining battery life at any time by pressing the adjacent button.

The head can rotate through 180 degrees, to enable the operator to work in the most comfortable position, and can easily be opened to allow cutting of running cables.

Fitted with a maximum hydraulic pressure valve.

Designed with improved balance, B-TC450 is easily manageable during the cutting process and, by the use of bi-component plastics, has a shell with high resistance to wear and damage.

Rubber grip inserts, low noise and minimal vibration aid operator comfort while additional convenience and safety are provided by LED lighting of the working area.

Operating temperature: -15 to +50 °C

B-TC500Y

18.0 V CORDLESS HYDRAULIC CUTTING TOOL

overhead line application

MAIN APPLICATIONS

specifically designed to cut Copper, Aluminum, Aluminum-Steel cables (ACSR) having Ø max 50 mm
Not suitable for cutting stay wire, Steel rope or earthing rod



TECHNICAL FEATURES

Max cutting Ø mm	50
Dimensions mm	
Length	405
Height	398
Width	83
Battery	18.0V 5.2Ah
Weight kg (with Battery)	5,8

STORAGE

Type	VAL-P40
Dimensions mm L x W x H	520 x 432 x 126
Weight kg	2,6
Supplied with the tool	✓
Purchase separately	-



The tool is supplied as:

- Basic tool with battery and shoulder strap
- Spare battery
- Battery charger
- USB cable
- Plastic carrying case suitable for storing the tool and accessories

Next generation of 18.0 V cordless hydraulic cutting tool specifically designed to cut Copper, Aluminium, Aluminum-Steel cables (ACSR) having a max overall diameter of 50 mm. The blades are manufactured from high strength special Steel, heat treated to ensure a long service life. New Li-Ion 18.0V - 5.2Ah batteries offer a higher capacity, while greater cutting speed and cutting force result from a revitalised hydraulic system with double speed action. The battery is equipped with LED indicators to show the remaining battery life at any time by pressing the adjacent button.

The head can rotate through 90 degrees, to enable the operator to work in the most comfortable position, and can easily be opened to allow cutting of running cables. Fitted with a maximum hydraulic pressure valve. Designed with improved balance, B-TC500Y is easily manageable during the cutting process and, by the use of bi-component plastics, has a shell with high resistance to wear and damage. Rubber grip inserts, low noise and minimal vibration aid operator comfort while additional convenience and safety are provided by LED lighting of the working area. Operating temperature: -15 to +50 °C

18.0 V CORDLESS HYDRAULIC CUTTING TOOL

overhead line application

MAIN APPLICATIONS

specifically designed to cut Copper, aldrej, Aluminium, Aluminium-Steel cables and Steel ropes, Aluminium and Steel rods having Ø max 55 mm



TECHNICAL FEATURES

Max cutting Ø mm	55
Dimensions mm	
Length	441
Height	424
Width	87
Battery	18.0V 5.2Ah
Weight kg (with Battery)	8,9

STORAGE

Type	VAL-P40
Dimensions mm L x W x H	520 x 432 x 126
Weight kg	2,6
Supplied with the tool	✓
Purchase separately	-

CUTTING CAPACITY - a few examples

	MATERIAL	TENSILE STRENGTH (daN/mm ²)	MAX CUTTING DIAMETER (mm)
			B-TC550
ROPE & CONDUCTORS	COPPER	≤ 41	55
	ALUMINIUM	≤ 20	55
	ALMELEC	≤ 34	55
	STEEL	≤ 180	INDICATIVE EXAMPLES: 7 x 3,0 : Ø est. = 9,0 mm 19 x 2,1 : Ø est. = 10,5 mm 19 x 2,3 : Ø est. = 11,5 mm
	MULTI STRANDS STEEL (STRANDS Qty ≥ 200)	≤ 180	22
	ACSR	≤ 180	50 INDICATIVE EXAMPLES: 26 x 2,50 + 7 x 1,95 : Ø est. = 15,85 26 x 3,06 + 7 x 2,38 : Ø est. = 19,38 26 x 3,60 + 7 x 2,80 : Ø est. = 22,80 26 x 4,44 + 7 x 3,45 : Ø est. = 28,14 54 x 3,50 + 19 x 2,10 : Ø est. = 31,50 54 x 4,36 + 19 x 2,62 : Ø est. = 39,20 83 x 4,60 + 16 x 2,80 : Ø est. = 50,00
	GUY WIRE (GW15-9/16-188)	Extra high strenght grade	7 x 4,77 : Ø est. = 14,30 mm
RODS	STEEL	≤ 60	20
		≤ 42	22
	COPPER	≤ 30	34
		≤ 25	38,5
	ALUMINIUM	≤ 16	50

B-TC550

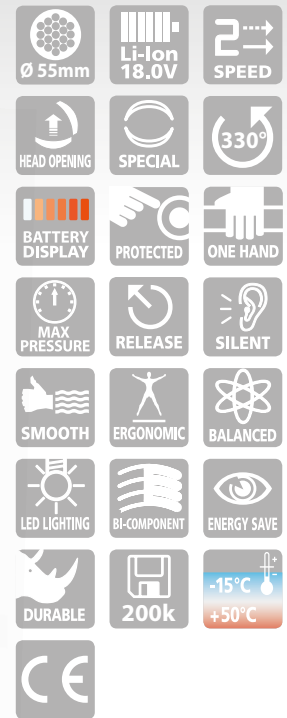

The tool is supplied as:

- Basic tool with battery and shoulder strap
- Spare battery
- Battery charger
- USB cable
- Plastic carrying case suitable for storing the tool and accessories



Next generation of 18.0 V cordless hydraulic cutting tool Specifically designed cut Copper, Aldrej, Aluminium, Aluminium-Steel cables and Steel ropes, Aluminium and Steel rods having a max overall diameter of 55 mm.

The blades are manufactured from high strength special Steel, heat treated to ensure a long service life. New Li-Ion 18.0V - 5.2Ah batteries offer a higher capacity, while greater cutting speed and cutting force result from a revitalised hydraulic system with double speed action. The battery is equipped with LED indicators to show the remaining battery life at any time by pressing the adjacent button.

The head can rotate through 330 degrees, to enable the operator to work in the most comfortable position, and can easily be opened to allow cutting of running cables.

Fitted with a maximum hydraulic pressure valve.

Designed with improved balance, B-TC550 is easily manageable during the cutting process and, by the use of bi-component plastics, has a shell with high resistance to wear and damage.

Rubber grip inserts, low noise and minimal vibration aid operator comfort while additional convenience and safety are provided by LED lighting of the working area.

Operating temperature:

-15 to +50 °C

B-TC320NDF

18.0 V CORDLESS HYDRAULIC CUTTING TOOL

industrial application

MAIN APPLICATIONS

specifically designed to cut Copper, Aluminium and Telecommunications cable having Ø max 32 mm



TECHNICAL FEATURES

Max cutting Ø mm	32
Dimensions mm	
Length	444
Height	136
Width	81
Battery	18.0V 2.0Ah
Weight kg (with Battery)	4,0

STORAGE

Type	VAL-P48
Dimensions mm L x W x H	620 x 360 x 138
Weight kg	2,4
Supplied with the tool	✓
Purchase separately	-



B-TC320NDF is a new generation of hand-held cordless tools, characterised by a "Bilinear" mechanical design.

B-TC320NDF is specifically designed to cut Copper, Aluminium and telecommunication cable having a max overall diameter of 32 mm.

The blades are manufactured from high strength special Steel, heat treated to ensure a long service life. New Li-Ion 18.0V - 2.0Ah batteries offer a higher capacity, while greater cutting speed and cutting force result from a revitalised hydraulic system with double speed action.

The battery is equipped with led indicators that indicate the remaining battery life at any time by pressing the adjacent button.

The head can rotate through 180 degrees, to enable the operator to work in the most comfortable position, and can easily be opened to allow cutting of running cables.

Fitted with a maximum hydraulic pressure valve.

Weight and balance have been re-configured to yield improvements in handling and convenience.

The more rigid structure of the bi-component plastic body provides greater mechanical protection while its rubber inserts boost operator safety and comfort. Quieter operation, illumination of the working area via LED lights and a minimum of vibration enhance the tool's practicality.

Two batteries and charger included. Same charger of all our tools.

Operating temperature:
-15 to +50 °C

The tool is supplied as:

- Basic tool with battery and wrist strap
- Spare battery
- Battery charger
- USB cable
- Plastic carrying case suitable for storing the tool and accessories

18.0 V CORDLESS HYDRAULIC CUTTING TOOL

industrial application

MAIN APPLICATIONS

specifically designed to cut Copper, Aluminium and Telecommunications cable having Ø max 52,5 mm

TECHNICAL FEATURES

Max cutting Ø mm	52,5
Dimensions mm	
Length	526
Height	152
Width	81
Battery	18.0V 2.0Ah
Weight kg (with Battery)	3,91

STORAGE

Type	VAL-P59
Dimensions mm L x W x H	620 x 360 x 138
Weight kg	2,4
Supplied with the tool	✓
Purchase separately	-



The tool is supplied as:

- Basic tool with battery and wrist strap
- Spare battery
- Battery charger
- USB cable
- Plastic carrying case suitable for storing the tool and accessories

B-TC500ND-SC is a new generation of hand-held cordless tools, characterised by a "Bilinear" mechanical design.

B-TC500ND-SC is specifically designed to cut Copper, Aluminium and telecommunication cable having a max overall diameter of 52,5 mm.

The blades are manufactured from high strength special Steel, heat treated to ensure a long service life. New Li-Ion 18.0V - 2.0Ah batteries offer a higher capacity, while greater cutting speed and cutting force result from a revitalised hydraulic system with double speed action.

The battery is equipped with led indicators that indicate the remaining battery life at any time by pressing the adjacent button.



Quieter operation, illumination of the working area via LED lights and a minimum of vibration enhance the tool's practicality.

Two batteries and charger included. Same charger of all our tools.

Operating temperature:

-15 to +50 °C

The head can rotate through 180 degrees, to enable the operator to work in the most comfortable position, and can easily be opened to allow cutting of running cables.

Fitted with a maximum hydraulic pressure valve.

Weight and balance have been re-configured to yield improvements in handling and convenience.

The more rigid structure of the bi-component plastic body provides greater mechanical protection while its rubber inserts boost operator safety and comfort.

B-TC500

18.0 V CORDLESS HYDRAULIC CUTTING TOOL

industrial application

MAIN APPLICATIONS

specifically designed to cut Copper, Aluminium and Telecommunications cable having Ø max 50 mm



TECHNICAL FEATURES

Max cutting Ø mm	50
Dimensions mm	
Length	405
Height	398
Width	83
Battery	18.0V 5.2Ah
Weight kg (with Battery)	5,8

STORAGE

Type	VAL-P40
Dimensions mm L x W x H	520 x 432 x 126
Weight kg	2,6
Supplied with the tool	✓
Purchase separately	-



Next generation of 18.0 V cordless hydraulic cutting tool specifically designed to cut Copper, Aluminium and telecommunication cable having a max overall diameter of 50 mm. The blades are manufactured from high strength special Steel, heat treated to ensure a long service life. New Li-Ion 18.0V - 5.2Ah batteries offer a higher capacity, while greater cutting speed and cutting force result from a revitalised hydraulic system with double speed action.

The battery is equipped with LED indicators to show the remaining battery life at any time by pressing the adjacent button. The head can rotate through 90 degrees, to enable the operator to work in the most comfortable position, and can easily be opened to allow cutting of running cables. Fitted with a maximum hydraulic pressure valve.

Designed with improved balance, B-TC500 is easily manageable during the cutting process and, by the use of bi-component plastics, has a shell with high resistance to wear and damage. Rubber grip inserts, low noise and minimal vibration aid operator comfort while additional convenience and safety are provided by LED lighting of the working area. Operating temperature: -15 to +50 °C

The tool is supplied as:

- Basic tool with battery and shoulder strap
- Spare battery
- Battery charger
- USB cable
- Plastic carrying case suitable for storing the tool and accessories

18.0 V CORDLESS HYDRAULIC CUTTING TOOL

industrial application

MAIN APPLICATIONS

specifically designed to cut Copper, Aluminium and Telecommunications cable having Ø max 65 mm



TECHNICAL FEATURES

Max cutting Ø mm	65
Dimensions mm	
Length	429
Height	415
Width	83
Battery	18.0V 5.2Ah
Weight kg (with Battery)	6,4



STORAGE

Type	VAL-P40
Dimensions mm L x W x H	520 x 432 x 126
Weight kg	2,6
Supplied with the tool	✓
Purchase separately	-



The tool is supplied as:

- Basic tool with battery and shoulder strap
- Spare battery
- Battery charger
- USB cable
- Plastic carrying case suitable for storing the tool and accessories

Next generation of 18.0 V cordless hydraulic cutting tool specifically designed to cut Copper, Aluminium and telecommunication cable having a max overall diameter of 65 mm. The blades are manufactured from high strength special Steel, heat treated to ensure a long service life.

New Li-Ion 18.0V - 5.2Ah batteries offer a higher capacity, while greater cutting speed and cutting force result from a revitalised hydraulic system with double speed action. The battery is equipped with LED indicators to show the remaining battery life at any time by pressing the adjacent button. The head can rotate through 335 degrees, to enable the operator to work in the most comfortable position, and can easily be opened to allow cutting of running cables. Fitted with a maximum hydraulic pressure valve.

Designed with improved balance, B-TC650 is easily manageable during the cutting process and, by the use of bi-component plastics, has a shell with high resistance to wear and damage. Rubber grip inserts, low noise and minimal vibration aid operator comfort while additional convenience and safety are provided by LED lighting of the working area. Operating temperature: -15 to +50 °C



B-TC650-SC

18.0 V CORDLESS HYDRAULIC CUTTING TOOL

industrial application

MAIN APPLICATIONS

specifically designed to cut Copper, Aluminium and Telecommunications cable having Ø max 65 mm



TECHNICAL FEATURES

Max cutting Ø mm	65
Dimensions mm	
Length	503
Height	464
Width	105
Battery	18.0V 5.2Ah
Weight kg (with Battery)	7,7

STORAGE

Type	VAL-B-TC950
Dimensions mm L x W x H	565 x 410 x 132
Weight kg	6,7
Supplied with the tool	✓
Purchase separately	-

Next generation of 18.0 V cordless hydraulic cutting tool specifically designed to cut Copper, Aluminium and telecommunication cable having a max overall diameter of 65 mm. The blades are manufactured from high strength special Steel, heat treated to ensure a long service life. The open head and the "scissor" movement of the blades facilitate the cutting of running cables. New Li-Ion 18.0V - 5.2Ah batteries offer a higher capacity, while greater cutting speed and cutting force result from a revitalised hydraulic system with double speed action.

The battery is equipped with LED indicators to show the remaining battery life at any time by pressing the adjacent button. The head can rotate through 180 degrees, to enable the operator to work in the most comfortable position, and can easily be opened to allow cutting of running cables. Fitted with a maximum hydraulic pressure valve. Designed with improved balance, B-TC650-SC is easily manageable during the cutting process and, by the use of bi-component plastics, has a shell with high resistance to wear and damage.

Rubber grip inserts, low noise and minimal vibration aid operator comfort while additional convenience and safety are provided by LED lighting of the working area. Operating temperature: -15 to +50 °C



The tool is supplied as:

- Basic tool with battery and shoulder strap
- Spare battery
- Battery charger
- USB cable
- Metal carrying case suitable for storing the tool and accessories

18.0 V CORDLESS HYDRAULIC CUTTING TOOL

industrial application

MAIN APPLICATIONS

specifically designed to cut Copper, Aluminium and Telecommunications cable having Ø max 95 mm



TECHNICAL FEATURES

Max cutting Ø mm	95
Dimensions mm	
Length	518
Height	468
Width	83
Battery	18.0V 5.2Ah
Weight kg (with Battery)	7,8

Next generation of 18.0 V cordless hydraulic cutting tool specifically designed to cut Copper, Aluminium and telecommunication cable having a max overall diameter of 95 mm. The blades are manufactured from high strength special Steel, heat treated to ensure a long service life. New Li-Ion 18.0V - 5.2Ah batteries offer a higher capacity, while greater cutting speed and cutting force result from a revitalised hydraulic system with double speed action. The battery is equipped with LED indicators to show the remaining battery life at any time by pressing the adjacent button.

The head can rotate through 335 degrees, to enable the operator to work in the most comfortable position, and can easily be opened to allow cutting of running cables. Fitted with a maximum hydraulic pressure valve. Designed with improved balance, B-TC950 is easily manageable during the cutting process and, by the use of bi-component plastics, has a shell with high resistance to wear and damage.

Rubber grip inserts, low noise and minimal vibration aid operator comfort while additional convenience and safety are provided by LED lighting of the working area. Operating temperature: -15 to +50 °C

B-TC950



STORAGE

Type	VAL-B-TC950
Dimensions mm L x W x H	565 x 410 x 132
Weight kg	6,7
Supplied with the tool	✓
Purchase separately	-



The tool is supplied as:

- Basic tool with battery and shoulder strap
- Spare battery
- Battery charger
- USB cable
- Metal carrying case suitable for storing the tool and accessories

B-TC4500

18.0 V CORDLESS HYDRAULIC CUTTING TOOL

overhead line application

MAIN APPLICATIONS

specifically designed to cut Copper, aldrej, Aluminium, Aluminium-Steel cables and Steel ropes, Aluminium and Steel rods having Ø max 45 mm



TECHNICAL FEATURES

Max cutting Ø mm	45
Dimensions mm	
Length	486
Height	239
Width	103
Battery	18.0V 5.2Ah
Weight kg (with Battery)	6,44

STORAGE

Type	VAL-P54
Dimensions mm L x W x H	690 x 446 x 179
Weight kg	5,5
Supplied with the tool	✓
Purchase separately	-



The tool is supplied as:

- Basic tool with battery and shoulder strap
- Spare battery
- Battery charger
- USB cable
- Plastic carrying case suitable for storing the tool and accessories



Next generation of 18.0 V cordless hydraulic cutting tool specifically designed to cut Copper, aldrej, Aluminium, Aluminium-Steel cables and Steel ropes, Aluminium and Steel rods having a max overall diameter of 45 mm.

The blades are manufactured from high strength special Steel, heat treated to ensure a long service life. New Li-Ion 18.0V - 5.2Ah batteries offer a higher capacity, while greater cutting speed and cutting force result from a revitalised hydraulic system with double speed action.

The battery is equipped with LED indicators to show the remaining battery life at any time by pressing the adjacent button.

The head can rotate through 180 degrees, to enable the operator to work in the most comfortable position, and can easily be opened to allow cutting of running cables.

Fitted with a maximum hydraulic pressure valve.

Designed with improved balance, B-TC4500 is easily manageable during the cutting process and, by the use of bi-component plastics, has a shell with high resistance to wear and damage.

Rubber grip inserts, low noise and minimal vibration aid operator comfort while additional convenience and safety are provided by LED lighting of the working area.

Operating temperature: -15 to +50 °C

CUTTING CAPACITY - a few examples

	MATERIAL	TENSILE STRENGTH (daN/mm ²)	MAX CUTTING DIAMETER (mm)
			B-TC4500
ROPE & CONDUCTORS	COPPER	≤ 41	45
	ALUMINIUM	≤ 20	45
	ALMELEC	≤ 34	45
	STEEL	≤ 180	INDICATIVE EXAMPLES: 7 x 3,0 : Ø est. = 9,0 mm 19 x 2,1 : Ø est. = 10,5 mm 19 x 2,3 : Ø est. = 11,5 mm
	MULTI STRANDS STEEL (STRANDS Qty ≥ 200)	≤ 180	18
	ACSR	≤ 180	45 INDICATIVE EXAMPLES: 26 x 2,50 + 7 x 1,95 : Ø est. = 15,85 26 x 3,06 + 7 x 2,38 : Ø est. = 19,38 26 x 3,60 + 7 x 2,80 : Ø est. = 22,80 54 x 3,50 + 19 x 2,10 : Ø est. = 31,50 54 x 4,36 + 19 x 2,62 : Ø est. = 39,20
RODS	STEEL	≤ 60	18
		≤ 42	20
	COPPER	≤ 30	30
		≤ 25	32
	ALUMINIUM	≤ 16	45

18.0 V Cordless hydraulic Frame-Type hole punching tool

B-FC470

general features

MAIN APPLICATIONS

specifically designed to punching holes from 15,5 up to 47,2 mm diameter

TECHNICAL FEATURES

Max hole punch Ø mm	47,2
Max centre of hole to edge of trunking (mm)	53,5
Dimensions mm	
Length	379
Height	346
Width	83
Battery	18.0V 5.2Ah
Weight kg (with Battery)	6,2

STORAGE

Type	VAL-FC470
Dimensions mm L x P	559 x 459 x 131
Weight kg	6,7
Supplied with the tool	✓
Purchase separately	-



The tool is supplied as:

- Basic tool with battery and shoulder strap
- Spare battery
- Battery charger
- USB cable
- Metal carrying case suitable for storing the tool and accessories

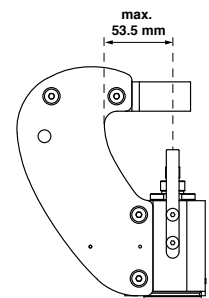

Next generation of 18.0 V cordless hydraulic cutting tool specifically designed to punching holes from 15,5 up to 47,2 mm diameter in the side wall of trunking without the need for pre drilling.

New Li-Ion 18.0V - 5.2Ah batteries offer a higher capacity, while greater punch speed and punching force result from a revitalised hydraulic system with double speed action.

The battery is equipped with led indicators that indicate the remaining battery life at any time by pressing the adjacent button.

The head can rotate through 180 degrees, to enable the operator to work in the most comfortable position, and can easily be opened to allow cutting of running cables.

Fitted with a maximum hydraulic pressure valve.

Designed with improved balance, B-FC470 is easily manageable during the punching process and, by the use of bi-component plastics, has a shell with high resistance to wear and damage.

Rubber grip inserts, low noise and minimal vibration aid operator comfort while additional convenience and safety are provided by LED lighting of the working area.

Operating temperature: -15 to +50 °C

Also available in the hand operated mechanical version MT-FC48N (see page 132).

Table denotes the punch/die set reference, for each hole size. Suitable for punching holes in mild Steel, fibreglass or plastic material, up to 2 mm thick.

Hole Dimensions					Maximum thickness of mild Steel (mm)	Type
Nominal						
Ø (mm)	Ø (inch)	Pg	ISO	Inch		
15,5	.610	Pg9	-	-	2	RD15.5SS-FC
16,2	.638	-	ISO-16	-		RD16.2SS-FC
17,5	.689	-	-	-		RD17.5SS-FC
18,8	.740	Pg11	-	-		RD18.8SS-FC
19,1	.752	-	-	-		RD19.1SS
20,5	.807	Pg 13,5	ISO-20	-		RD20.5SS
22,6	.890	Pg16	-	-		RD22.6SS
23,8	.937	-	-	5/8"		RD23.8SS
25,4	1.000	-	ISO-25	-		RD25.4SS
27,0	1.063	-	-	3/4"		RD27SS
28,5	1.122	Pg21	-	-		RD28.5SS
30,5	1.201	-	-	7/8"		RD30.5SS
31,8	1.252	-	-	-		RD31.8SS
32,5	1.279	-	ISO-32	-		RD32.5SS
34,6	1.362	-	-	-		RD34.6SS
37,2	1.464	Pg29	-	-		RD37.2SS
38,1	1.500	-	-	-		RD38.1SS
40,5	1.594	-	ISO-40	-		RD40.5SS-FC
41,3	1.626	-	-	-		RD41.3SS-FC
42,5	1.673	-	-	1 1/4"		RD42.5SS-FC
43,2	1.701	-	-	-	RD43.2SS-FC	
44,5	1.752	-	-	-	RD44.5SS-FC	
47,2	1.858	Pg36	-	-	RD47.2SS-FC	

general features

MAIN APPLICATIONS

specifically designed for hole punching stainless Steel, mild Steel, fibreglass and plastic sheet materials up to 3,5 mm thickness



TECHNICAL FEATURES

Max Punching Ø mm	140
Dimensions mm	
Length	474
Height	136
Width	81
Battery	18.0V 2.0Ah
Weight kg (with Battery)	4,1

STORAGE

Type	VAL-P57
Dimensions mm L x W x H	620 x 360 x 138
Weight kg	2,4
Supplied with the tool	✓
Purchase separately	-

The tool is supplied as:

- Basic tool with battery and wrist strap
- Spare battery
- Battery charger
- USB cable
- Puller TD-11
- Puller TD-19
- Spiral bit Ø 11,5 mm
- Plastic carrying case suitable for storing the tool and accessories



B-FL750ND is a new generation of hand-held cordless tools, characterised by a "Bilinear" mechanical design.

B-FL750ND is specifically designed for hole punching stainless Steel, mild Steel, fibreglass and plastic sheet materials up to 3,5 mm thickness.

New Li-Ion 18.0V - 2.0Ah batteries offer a higher capacity, while greater punch speed and punching force result from a revitalised hydraulic system with double speed action.

The battery is equipped with LED indicators that indicate the remaining battery life at any time by pressing the adjacent button.

The balanced punching head pivots 180deg through a full 360deg rotation for ease of use in confined spaces.

Fitted with a maximum hydraulic pressure valve.

Designed with improved balance, B-FL750ND is easily manageable during the punching process and, by the use of bi-component plastics, has a shell with high resistance to wear and damage.

Rubber grip inserts, low noise and minimal vibration aid operator comfort while additional convenience and safety are provided by LED lighting of the working area.

For the punch-die selection chart see page 215.

Operating temperature: -15 to +50 °C

18.0 V Cordless hydraulic Puller-Type hole punching tool

B-FL750

general features

MAIN APPLICATIONS

specifically designed for hole punching stainless Steel, mild Steel, fibreglass and plastic sheet materials up to 3,5 mm thickness

TECHNICAL FEATURES

Max Punching Ø mm	140
Dimensions mm	
Length	363
Height	366
Width	83
Battery	18.0V 5.2Ah
Weight kg (with Battery)	5,1

STORAGE

Type	VAL-P56
Dimensions mm L x W x H	690 x 446 x 179
Weight kg	5,5
Supplied with the tool	✓
Purchase separately	-

The tool is supplied as:

- Basic tool with battery and shoulder strap
- Spare battery
- Battery charger
- USB cable
- Puller TD-11
- Puller TD-19
- Spiral bit Ø 11,5 mm
- Plastic carrying case suitable for storing the tool and accessories



Universal joint allows punching head to pivot 180deg over a full 360deg rotation.

Next generation of 18.0V cordless hydraulic tool specifically designed for hole punching stainless Steel, mild Steel, fibreglass and plastic sheet materials up to 3,5 mm thickness.

New Li-Ion 18.0V - 5.2Ah batteries offer a higher capacity than 14.4 V 3 Ah, while greater punch speed and punching force result from a revitalised hydraulic system with double speed action.

The battery is equipped with LED indicators to show the remaining battery life at any time by pressing the adjacent button.

The balanced punching head pivots 180deg through a full 360deg rotation for ease of use in confined spaces.

Fitted with a maximum hydraulic pressure valve.

Designed with improved balance, B-FL750 is easily manageable during the punching process and, by the use of bi-component plastics, has a shell with high resistance to wear and damage.

Rubber grip inserts, low noise and minimal vibration aid operator comfort while additional convenience and safety are provided by LED lighting of the working area.

For the punch-die selection chart see page 215.

Operating temperature: -15 to +50 °C

KIT-B-FL750-1

KIT for hole punching

general features



TECHNICAL FEATURES

Max Punching Ø mm	140
Dimensions mm	
Length	363
Height	366
Width	83
Battery	18.0V 5.2Ah
Weight kg (with Battery)	5,1

STORAGE

Type	VAL-P56
Dimensions mm L x W x H	690 x 446 x 179
Weight kg	5,5
Supplied with the tool	✓
Purchase separately	-



KIT-B-FL750-1

Kit includes:

B-FL750 cordless hydraulic puller-type hole punching tool

VAL-P56 plastic carrying case with accessories

Puller TD-11

Puller TD-19

spiral bit Ø 11,5 mm

4 KIT for round punch:

KIT-RD18.8SS	Pg11
KIT-RD20.5SS	Pg13.5
KIT-RD22.6SS	Pg16
KIT-RD28.5SS	Pg21

The tool is supplied as:

- Basic tool with battery and shoulder strap
- Spare battery
- Battery charger
- USB cable
- Puller TD-11, Puller TD-19
- Spiral bit Ø 11,5 mm
- Plastic carrying case suitable for storing the tool and accessories

Punching accessories available

for B-FL750ND, B-FL750 and KIT-B-FL750-1

Round punch

Hole diameter					Material max thickness (mm)		Pilot hole Ø (mm)	Type	
Nominal Ø (mm)	Ø (inch)	Pg	ISO	GAS	Stainless Steel	Mild Steel		KIT (Punch + Die)	Puller
15,5	.610	Pg9	-	-	2,5 mm (0.1 in.) Rm= 700 N/mm ²	3,5 mm (0.14 in.) Rm= 510 N/mm ²	RD15.5SS	TD-11	
16,2	.638	-	ISO-16	-					
17,0	.669	-	-	G3/8"					
17,5	.689	-	-	-					
18,8	.740	Pg11	-	-					
19,1	.752	-	-	-					
20,5	.807	Pg 13,5	ISO-20	-					
21,5	.846	-	-	G1/2"					
22,6	.890	Pg16	-	-					
23,8	.937	-	-	G5/8"					
25,4	1.000	-	ISO-25	-					
27,0	1.063	-	-	G3/4"					
28,5	1.122	Pg21	-	-					
30,5	1.201	-	-	G7/8"					
28,5	1.122	Pg 21	-	-					
30,5	1.201	-	-	G7/8"					
31,8	1.252	-	-	-					
32,5	1.279	-	ISO-32	-					
34,0	1.338	-	-	G1"					
34,6	1.362	-	-	-					
37,2	1.464	Pg29	-	-					
38,1	1.500	-	-	-					
38,5	1.515	-	-	G1 1/8"					
40,5	1.594	-	ISO-40	-					
41,3	1.626	-	-	-					
42,5	1.673	-	-	G1 1/4"					
43,2	1.701	-	-	-					
44,5	1.752	-	-	-					
47,2	1.858	Pg36	-	-					
48,5	1.909	-	-	G1 1/2"					
50,5	1.988	-	ISO-50	-					
51,4	2.023	-	-	-					
52,4	2.063	-	-	-					
54,2	2.134	Pg42	-	G1 3/4"					
60,0	2.362	Pg48	-	G2"					
60,5	2.381	-	-	-					
64,0	2.520	-	ISO-63	-					
65,0	2.559	-	-	-					
76,0	2.992	-	-	G2 1/2"					
76,5	3.011	-	-	-					
80,5	3.169	-	-	-					
89,0	3.503	-	-	G3"					
90,0	3.543	-	-	-					
100,0	3.937	-	-	-					
102,0	4.015	-	-	-					
114,0	4.488	-	-	-					
120,0	4.724	-	-	-					
140,0	5.512	-	-	-					
							RD16.2SS		
							RD17.5SS		
							RD18.8SS		
							RD19.1SS		
							RD20.5SS		
							RD21.5SS		
							RD22.6SS		
							RD23.8SS		
							RD25.4SS		
							RD27.5SS		
							RD28.5SS		
							RD30.5SS		
							RD28.5SS-19		
							RD30.5SS-19		
							RD31.8SS		
							RD32.5SS		
							RD34.5SS		
							RD34.6SS		
							RD37.2SS		
							RD38.1SS		
							RD38.5SS		
							RD40.5SS		
							RD41.3SS		
							RD42.5SS		
							RD43.2SS		
							RD44.5SS		
							RD47.2SS	TD-19	
							RD48.5SS		
							RD50.5SS		
							RD51.4SS		
							RD52.4SS		
							RD54.2SS		
							RD60.5SS		
							RD60.5SS		
							RD64.5SS		
							RD65.5SS		
							RD76.5SS		
							RD76.5SS		
							RD80.5SS		
							RD89.5SS		
							RD90.5SS		
							RD100.5SS		
							RD102.5SS		
							RD114.5SS	TD-28.5*	
							RD120.5SS		
							RD140.5SS		

Stainless Steel = Rm= 700 N/mm² - Mild Steel = Rm= 510 N/mm²

* Puller included in the kit

Square punch

Hole dimensions		Material max thickness (mm)		Pilot hole Ø (mm)	Type
Nominal (mm)	(inch)	Stainless Steel	Mild Steel		
21,0 x 21,0	.827 x .827	2,5	3,5	12,0	RD21X21
46,0 x 46,0	1.811 x 1.811	1,5	2,0	26,5	RD46X46
68,0 x 68,0	2.677 x 2.677			28,5	RD68X68
92,0 x 92,0	3.622 x 3.622				RD92X92
126,0 x 126,0	4.960 x 4.960				RD126X126
138,0 x 138,0	5.433 x 5.433	1,0	1,5	RD138X138	
220,0 x 220,0	8.661 x 8.661			RD220X220	
224,0 x 224,0	8.818 x 8.818			RD224X224	

Rectangular punch

Hole dimensions		Material max thickness (mm)		Pilot hole Ø (mm)	Type
Nominal (mm)	(inch)	Stainless Steel	Mild Steel		
18,0 x 46,0	.709 x 1.811	2,0	2,0	16,5	RD18X46
22,0 x 30,0	.866 x 1.181				RD22X30
22,0 x 46,0	.866 x 1.811				RD22X46
29,0 x 71,0	1.141 x 2.795				RD29X71
35,0 x 65,0	1.377 x 2.559				RD35X65
35,0 x 86,0	1.377 x 3.385			RD35X86	
35,0 x 112,0	1.377 x 4.409			RD35X112	
36,0 x 46,0	1.417 x 1.811			RD36X46	
37,0 x 54,0	1.456 x 2.125			RD37X54	
37,0 x 67,0	1.456 x 2.637			RD37X67	
37,0 x 88,0	1.456 x 3.464	RD37X88			
37,0 x 104,0	1.456 x 4.094	26,5	RD37X104		
37,0 x 115,0	1.456 x 4.527		RD37X115		
46,0 x 54,0	1.811 x 2.126		RD46X54		
46,0 x 72,0	1.811 x 2.835		RD46X72		
46,0 x 92,0	1.811 x 3.622		RD46X92		
46,0 x 107,0	1.811 x 4.212	RD46X107			
50,0 x 98,0	1.968 x 3.858	RD50X98			
67,0 x 126,0	2.637 x 4.960	28,5	RD67X126		
72,0 x 136,0	2.834 x 5.354		RD72X136		

Stainless Steel = Rm= 700 N/mm² - Mild Steel = Rm= 510 N/mm²

"D" punch

Hole dimensions		Material max thickness (mm)		Pilot hole Ø (mm)	Type
Nominal (mm)	(inch)	Stainless Steel	Mild Steel		
(a)38,3 x (b)36,6	(a)1.507 x (b)1.442	2,5	3,5	18,5	RD 18D
(a)43,1 x (b)41,5	(a)1.696 x (b)1.632				RD 24D

Stainless Steel = Rm= 700 N/mm² - Mild Steel = Rm= 510 N/mm²

Use of non-Cembre punching accessories

Type	Punch & Die	Pilot hole Ø mm
TRD-9.4C (*)	GREENLEE 3/8" - 24 UNF	Ø 10.0
TRD-M11C (*)	BM, COSMEC (M11x1.5)	Ø 11.5
TD-M16C	BM, COSMEC (M16x1.5)	Ø 16.5
TD-27	BM, COSMEC (Ø105-Ø140)	Ø 27.5
TD-14X14-M14	BM, COSMEC 46x46	Ø 18.8
TD-120X20-M20	BM, COSMEC 92x92	Ø 27.5
TD-20X20-M20 (with plug)	BM, COSMEC 42x95	Ø 27.5
TGD-13.5X13.5-M13	BM, COSMEC 40x40; 45x45; 46x46 (M13)	Ø 18.8
TGD-10X10-M9	BM, COSMEC 006505	Ø 13.8
TD-9	IMB 9601	Ø 9.5
TD-16	IMB 9603	Ø 16.5
TD-10X10-M10 (with plug)	IMB 9623	Ø 14.5
TD-14X14-M14/1"	IMB 9625	Ø 19.5
TD-20 (without plug)	IMB 9626	Ø 27.5
TD-20X20-M20-C (with plug)	IMB 9626	Ø 27.5

(*) The washer supplied with the KIT must be threaded onto the draw stud and positioned between the head and the die to allow the die to rest correctly

MPC1



PRESSURE TEST DEVICE

for hydraulic pumps and tools

MPC1 device

The MPC1 device, complete with test adapter set, is used to measure the maximum oil pressure on all Cembre tools.

MPC2



MPC2 device

The MPC2 device, complete with test die set, to measure the maximum force developed by Cembre tools: HT131-C, HT131LN-C, HT120, HT120-KV, RHC131, RHC131-KV, RHC131LN, B131-C, B131-C-KV, B131LN-C, B131LN-C-KV, B135-C, B135-C-KV, B135LN-C, B135LN-C-KV.

MPC4



MPC4 device

The MPC4 device, complete with test die set, to measure the maximum force developed by Cembre tools: ECW-H3D, RHU240-3D-850, RHU300-3D

MPC7



MPC7 device

The MPC7 device, complete with test die set, to measure the maximum force developed by Cembre tools: HT45, HT51, HT51-KV, HT51L, HT51L-KV, RH50, HT61, RH61, B15D (use adaptor available separately), B35-45MD, B35-50MD, B46, B51, B51-KV, B51L, B51L-KV, B54D, B55, B55-KV, B62.



HYDRAULIC PUMPS AND UNITS

PO7000



Foot operated double speed pump, developing a maximum pressure of 700 bar.

The pump is supplied with 3 m long high pressure flexible hose complete with female self-lock quick coupler. Pressure can be withdrawn at any time during operation by depressing the release lever.

A solid shaped stand gives the pump stability during operation.

HYDRAULIC PUMP

foot operated

TECHNICAL FEATURES

Operating pressure bar	700
Dimensions mm	
Length	680
width	200
Height	163
Weight kg	9,8

STORAGE

Type	VAL-P21
Dimensions mm L x W x H	820 x 430 x 290
Weight kg	6,74
Supplied with the pump	✓
Purchase separately	-



CPP-0



The CPP-0 air hydraulic power unit intensifies an air supply of 6÷8 bar (87-115 psi) to a power crimping or cutting force of up to 700 bar (10.000 psi) depending upon the input pressure.

The control pedal allows for advancing and pressure release at any stage of the operation.

The unit is provided with a 2 m high pressure flexible hose, including a 3/8" NPT female self-lock quick coupler.

HYDRAULIC PUMP

foot operated

TECHNICAL FEATURES

Operating pressure bar	700
Dimensions mm	
Length	320
width	150
Height	200
Weight kg	6,8



HYDRAULIC PUMP

powered by single-phase electric motor

CPE-1

CPE-1-110

TECHNICAL FEATURES

Operating pressure bar	700
Dimensions mm	
Length	372
width	223
Height	482
Weight kg	21

The pump is supplied with:

- high pressure flexible hose with male and female automatic quick coupler
- remote hand controller
- external supply connection cable



Electrically driven hydraulic pump, powered by a 230V / 50-60Hz single-phase electric motor.

The remote hand controller allows advancement and pressure release on completion of the crimping operation.

The mechanically actuated emergency button located on the pump body allows the pressure release at any time in case of power shortage.

Also available CPE-1-110 version for 110-115V / 50-60Hz.

Both models are IP 55 rated.

Available as optional accessories:

- Remote foot controller RCP-B70.
- Transportation trolley CS-CPE-1
- Control handle integrated with 3 m length flex hoses ERCH-WH

ERCH-WH



RCP-B70



CS-CPE-1



B1300PL

PORTABLE ELECTRO-HYDRAULIC PUMP

battery operated



TECHNICAL FEATURES	
Operating pressure bar	700
Dimensions mm	
Length	354
width	103
Height	240
Battery	18.0V 5.2Ah
Weight kg (with Battery)	4,0

STORAGE	
Type	VAL-P51
Dimensions mm L x W x H	690 x 446 x 179
Weight kg	5,5
Supplied with the pump	✓
Purchase separately	-



New portable electro-hydraulic pump B1300PL is battery operated for independent use. Having the inherent strengths of the Cembre 18V tool range the B1300PL is a compact, lightweight pump suitable for a wide range of applications. New Li-Ion 18 V 5.2 Ah batteries offer a high capacity, while improved operating speed results from a revitalised hydraulic system with double speed action. A security valve assures operator safety.

Designed with improved handling characteristics, B1300PL is easily manageable during the operating process and, by the use of bi-component plastics, has a shell with high resistance to wear and damage. Rubber grip inserts, low noise and minimal vibration aid operator comfort while additional convenience and safety are provided by LED lighting of the working area. Pressure can be released at any time using the appropriate button.

The B1300PL pump is supplied with:

- 0,9 m flexible hose complete with male + female 3/8" NPT self-lock quick couplers.
- 18.0 V - 4.0 Ah Li-Ion high power battery
- Battery charger
- Shoulder strap
- Plastic carrying case suitable for storing the tool and accessories, type VALP51

APPLICATION RANGE		
Crimping	Cutting	Punching
up to 130 kN	up to TC 050	RH-FL75 RH-FC48N

PORTABLE ELECTRO-HYDRAULIC PUMP

battery operated

TECHNICAL FEATURES

Operating pressure bar	700
Dimensions mm	
Length	364
width	186
Height	236
Battery	18.0V 5.2Ah
Weight kg (with Battery)	5,6

STORAGE

Type	CVB-031
Dimensions mm L x W x H	620 x 300 x 320
Weight kg	2,4
Supplied with the pump	✓
Purchase separately	-



The B68M-P18 pump is supplied with:

- Remote control provides LED working lights and an OLED display
- 2 m flexible hose complete with rotatable Q14-F quick coupler on the pump and female 3/8" NPT self-lock quick couplers
- 18.0 V - 4.0 Ah Li-Ion high power battery (2 pcs.)
- Canvas bag suitable for storing the tool and accessories
- Battery charger
- Shoulder strap



APPLICATION RANGE

Crimping	Cutting	Punching
up to 230 kN	up to TC 120	RH-FL75 RH-FC48N

Example of operating information on OLED display:



Operating mode



Battery level

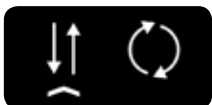

Release mode



No. of cycles

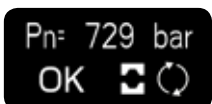

Pressure mode

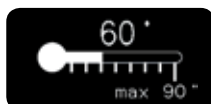

Motor temperature



New portable electro-hydraulic pump B68M-P18 is battery operated for independent use.

Having the inherent strengths of the Cembre 18V tool range, the B68M-P18 is a lightweight high capacity pump equipped with an innovative remote control suitable for a wide range of applications.

New Li-Ion 18V 5.2 Ah batteries offer a high capacity, while improved operating speed results from a revitalised hydraulic system with double speed action.

A maximum pressure sensor assures greater precision and repeatability of the pressure cycle, while a security valve doubles the provision for operator safety.

The unit has a manual pressure release button in case of emergency. Easy access to the oil reservoir is by means of an oil top-up inlet.

B68M-P18



The innovative remote control provides LED working lights and an OLED display of essential real time tool operating information including:

- Operating mode selection
- Release mode selection: Smart release, manual release
- Minimum set pressure and momentary pressure reached expressed in bar allows verification of correct operation
- Battery charge level
- No. of cycles performed
- No. of cycles before scheduled recommended maintenance
- Motor temperature

Designed with improved handling characteristics, B68M-P18 is easily manageable during the operating process and has a fibreglass-plastic shell with high resistance to wear and damage.

The pump features a rubber pocket to store and protect the remote control.

Low noise levels aid operator comfort while additional convenience and safety are provided by LED lighting on the remote control.

Selecting the SMART release mode on the OLED display allows the operating pressure to be maintained until the operating button is released, thus allowing the operator to make a visual check of, say, the crimped connection.

Releasing the button then automatically releases the pressure.

Crimping cycle data (up to 200,000 events) is automatically stored on a memory card for transfer to PC by USB interface located under the battery.

PORTABLE ELECTRO-HYDRAULIC PUMPS B70M-P36 RANGE

battery operated



Easily accessible oil top-up inlet



Toggle button for direct operation via the pump



Remote electrical hand or foot controller connection



High pressure hose connects to automatic self-lock quick coupling with protective cap



Automatic battery connection system



New generation pumps B70M-P36 are powered by an all new 36.0V 6.2Ah Li-Ion high capacity rechargeable battery providing independence and portability.

Fitted with a maximum pressure sensor (EPS) for enhanced precision and repeatability of the maximum pressure cycle, and a pressure relief valve providing additional safety for the operator. These units feature the Smart Release system which automatically retracts the ram at the end of the operating cycle.

The manual toggle button can be used to operate and release the pressure directly from the pump. (inhibited when the remote control is used for safety reasons). Oil top-up inlet for easy access to the oil reservoir. Extremely compact and suitable for a wide range of applications.

The Cembre logo acts as an indicator for the operator with instantaneous visual confirmation of the pumps status, such as; pump ready, pump in use, end of cycle, cycle error, anomaly, maintenance required.

The new design and ergonomic weight distribution allows the pump to be easily handled during use.

The rigid structure of the plastic body ensures adequate mechanical

protection and guarantees IP44M protection due to the presence of gaskets at the interface of the body shells.

The ergonomically designed handle helps to increase operator comfort when moving the pump.

Quieter operation, and the absence of vibrations ensure maximum operator comfort. Equipped with a 3m long high pressure hose complete with a male quick coupling on the pump and a self-locking female quick coupling. The pressure can be released at any time using the pressure release button.

The unit features an OLED display to provide essential real time tool oper-

ating information including:

- Operating mode selection (cutting, crimping or piercing)
- Release mode selection (Smart release, manual release)
- Minimum set pressure and snapshot pressure reached in bar/psi to allow verification of correct operation
- Battery charge level
- No. of cycles performed
- No. of cycles before scheduled recommended maintenance
- Motor temperature
- Operational command (hand controller or manual on the pump)

Can be used in vertical or horizontal position



OLED multifunctional display



Smart Logo



Manual pressure release button



Pump on (constant) In action (pulse)

End of cycle

Cycle error

Anomaly

Maintenance

PORTABLE ELECTRO-HYDRAULIC PUMP

battery operated

B70M-P36

- 1 Portable electro-hydraulic pump, 36V battery for independent use, developing 700 bar pressure
- 2 CB 3662L Battery 36 V - 6,2 Ah Li-Ion
- 3 ASC-ULTRA-EU External battery charger
- 4 USB cable
- 5 Shoulder strap
- 6 CVB-037 Canvas rucksack for carrying accessories
- 7 3 m flexible hose complete with male + female 3/8" NPT self-lock quick couplers
- 8 ERCH Remote control



TECHNICAL FEATURES

Operating pressure bar	700
Dimensions mm	
Length	405
width	161
Height	327
Battery	36V 6.2Ah
Weight kg (with Battery)	10.0*

*without accessories

PORTABLE ELECTRO-HYDRAULIC PUMP

battery operated

B70M-P36-CH

- 1 Portable electro-hydraulic pump, 36V battery for independent use, developing 700 bar pressure
- 2 CB 3662L Battery 36 V - 6,2 Ah Li-Ion
- 3 ASC-ULTRA-EU External battery charger
- 4 USB cable
- 5 Shoulder strap
- 6 CVB-037 Canvas rucksack for carrying accessories
- 9 ERCH-WH Remote hand controller integrated with 3 m length flexible hose complete with male + female 3/8" NPT self-lock quick couplers



TECHNICAL FEATURES

Operating pressure bar	700
Dimensions mm	
Length	405
width	161
Height	327
Battery	36V 6.2Ah
Weight kg (with Battery)	10.0*

*without accessories

Variously supplied with different versions:



ACCESSORIES FOR B70M-P36

purchase separately

TRS-B70

Canvas rucksack
(for carrying the pump)



ERCH-WH

Remote hand controller integrated
with 3 m length flexible hose



SH-B70

Hook for hanging the pump
from a ladder

VAL-P18

Durable transport case for pump and
accessories.



RCP-B70

Portable remote foot control

HYDRAULIC UNIT

CP1131

pump PO7000 + head RHC131

MAIN APPLICATIONS - max section sqmm

Section sqmm	0.25-1.5	1.5-2.5	4-6	10	16	25	35	50	70	95	120	150	185	200	240	300	400	500	630	800	1000	
L.V. lugs and splices																						
Insulated terminals																						
"C" sleeve Connectors																						
H.V. lugs																						
H.V. Splices*																						

*limited to the cable insulation diameter

These tools are supplied without dies. For die selection, please refer to chart on pages 248 to 262

TECHNICAL FEATURES

Crimping force kN	130
Dimensions mm	
Dimensions pump L x W x H	680 x 200 x 163
Dimensions head L x H	232 x 124
Weight unit kg	13,6

STORAGE

Type	VAL-P21*
Dimensions mm L x W x H	820 x 430 x 290
Weight kg	6,74
Supplied with the unit	✓

*Supplied with the unit, suitable for storage of 24 semi-circular slotted dies

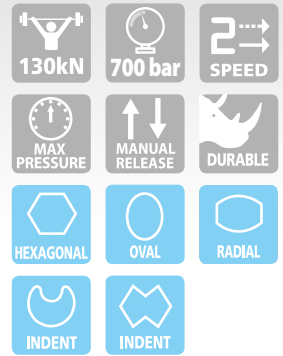

HYDRAULIC UNIT

CPU1131-C

pump PO7000 + head RHU131-C

MAIN APPLICATIONS - max section sqmm

Section sqmm	0.25-1.5	1.5-2.5	4-6	10	16	25	35	50	70	95	120	150	185	200	240	300	400	500	630	800	1000	
L.V. lugs and splices																						
Insulated terminals																						
"C" sleeve Connectors																						
Alu lugs and splices																						
H.V. lugs and splices																						

These tools are supplied without dies. For die selection, please refer to chart on pages 248 to 262

TECHNICAL FEATURES

Crimping force kN	130
Dimensions mm	
Dimensions pump L x W x H	680 x 200 x 163
Dimensions head L x H	245 x 89
Weight unit kg	13,5

STORAGE

Type	VAL-P21*
Dimensions mm L x W x H	820 x 430 x 290
Weight kg	6,74
Supplied with the unit	✓

*Supplied with the unit, suitable for storage of 24 semi-circular slotted dies and accessories for crimping Aluminium connectors



pump PO7000 + head ECW-H3D



MAIN APPLICATIONS - max section sqmm

Section sqmm	0,25÷1,5	1,5÷2,5	4÷6	10	16	25	35	50	70	95	120	150	185	200	240	300	400	500	630	800	1000	
L.V. lugs and splices																						
Insulated terminals																						
"C" sleeve Connectors																						
H.V. lugs and splices																						

These tools are supplied without dies. For die selection, please refer to chart on pages 248 to 262



TECHNICAL FEATURES

Crimping force kN	230
Dimensions mm	
Dimensions pump L x W x H	680 x 200 x 163
Dimensions head L x H	290 x 120
Weight unit kg	15,3

STORAGE

Type	VAL-P21*
Dimensions mm L x W x H	820 x 430 x 290
Weight kg	6,74
Supplied with the unit	✓

*Supplied with the unit, suitable for storage of 24 semi-circular slotted dies and adaptors and dies specific for head ECW-H3D



HYDRAULIC CUTTING UNIT

CP1096

pump PO7000 + head TC096

TECHNICAL FEATURES

Max cutting Ø mm	95
Dimensions mm	
Dimensions pump L x W x H	680 x 200 x 163
Dimensions head L x H	397 x 249
Weight unit kg	17,7

STORAGE

Type	VAL-CP096
Dimensions mm L x W x H	785 x 430 x 175
Weight kg	10,0
Supplied with the unit	✓



HYDRAULIC CUTTING UNIT

CP1120

pump PO7000 + head TC120

TECHNICAL FEATURES

Max cutting Ø mm	120
Dimensions mm	
Dimensions pump L x W x H	680 x 200 x 163
Dimensions head L x H	536 x 175
Weight unit kg	19,3

STORAGE

Type	VAL-22-TC120
Dimensions mm L x W x H	766 x 305 x 191
Weight kg	8,3
Supplied with the unit	✓

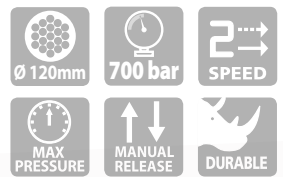

according to DIN EN 50340 - VDE 0682 part 661



GS approval
n. ET 13045

Hydraulic units provide protection against short circuit when accidentally cutting live L.V. / M.V. cables with nominal voltage up to 60 kV.

CP 1086-W-1000-KV TECHNICAL FEATURES

Max cutting Ø mm	85
Dimensions mm	
Dimensions pump L x W x H	680 x 200 x 163
Dimensions head L x H	405 x 143
Weight unit kg	16,6

CP 1096-W-1000-KV TECHNICAL FEATURES

Max cutting Ø mm	95
Dimensions mm	
Dimensions pump L x W x H	680 x 200 x 163
Dimensions head L x H	407 x 245
Weight unit kg	19,0

CP 1120-W-1000-KV TECHNICAL FEATURES

Max cutting Ø mm	120
Dimensions mm	
Dimensions pump L x W x H	680 x 200 x 163
Dimensions head L x H	556 x 185
Weight unit kg	20,2

Available as optional accessories:

- EK100 earth cable for the pump (1 m length)
- EK500P earth cable for the head (5 m length) with earth rod and canvas bag



STORAGE

Type	VAL-CP096-W
Dimensions mm L x W x H	785 x 430 x 175
Weight kg	10,0
Supplied with the unit	✓



PORTABLE BATTERY HYDRAULIC CUTTING UNITS

radio controlled - for remote cutting operations



B68RC3-85 TECHNICAL FEATURES	
Max cutting Ø mm	85
Dimensions mm	
Dimensions pump L x W x H	417 x 236 x 212
Dimensions head L x H	409 x 174 x 140
Weight unit kg	13,68

B68RC3-96 TECHNICAL FEATURES	
Max cutting Ø mm	95
Dimensions mm	
Dimensions pump L x W x H	417 x 236 x 212
Dimensions head L x H	498 x 249 x 147
Weight unit kg	17,24

B68RC3-120 TECHNICAL FEATURES	
Max cutting Ø mm	120
Dimensions mm	
Dimensions pump L x W x H	417 x 236 x 212
Dimensions head L x H	536 x 223 x 140
Weight unit kg	18,44

The heart of each unit is the new portable pump B68M-P18-KV-RC3, battery operated for independent use. Having the inherent strengths of the Cembre 18V tool range, the B68M-P18-KV-RC3 is a lightweight high capacity pump equipped with an innovative radio remote control designed specifically for man-hole environments to allow operators to control and operate the pump out of the man-hole at a safe distance. New Li-Ion 18V 7Ah batteries provide high capacity while improved operating speed results from a revitalized hydraulic system with double speed action. A maximum pressure sensor assures greater precision and repeatability of

the pressure cycle, while a security valve doubles the provision for operator safety. The unit is fitted with a patented unique system for stopping the pump when the cutting head sensor signals that its blades have travelled fully. At this point the LED indicator and buzzer notify the operator of the successful completion of the cutting operation. For this reason, each pump is paired to its specific cutting head only and it must be considered as a complete unit. The innovative remote control function is able to work in man-hole environment where radio communication is normally more complicated.

The unit features an OLED display to provide essential real time tool operating information including:

- Operating mode selection (cutting or crimping)
- Release mode selection (Smart release, manual release)
- Minimum set pressure and momentary pressure reached in bar/psi to allow verification of correct operation
- Battery charge level
- No. of cycles performed
- No. of cycles before scheduled recommended maintenance
- Motor temperature
- Operating command (radio or manual).

Available as optional accessories:

- CVB-031 Canvas bag
- EK100 Earth cable for the pump (1 m length)
- EK500P Earth cable for the head (5 m length) with earth rod and canvas bag



Supplied with:

- Radio remote control (2405 ÷ 2480 MHz)
- CB1870L, Li-Ion 18.0V 7.0 A h Battery (2 pcs)
- ASC30-36 EU 27044000, Battery charger
- Tubo flessibile isolato ad alta pressione da 10 m
- USB cable
- Shoulder strap
- VAL-B68RC3 Metal Carring Case

STORAGE

Type	VAL-B68RC3
Dimensions mm L x W x H	665 x 422 x 260
Weight kg	17,4
Supplied with the unit	✓



TF

Flexible hoses

High pressure flexible hoses for joining hydraulic heads to pumps. In addition to the standard versions listed below alternative hose lengths are available, upon request:



TF300-Q38FM

3 m length flexible hose fitted with an automatic female quick coupler and a male quick coupler.

TF600-Q38FM

6 m length flexible hose fitted with an automatic female quick coupler and a 3/8" NPT male threaded bush.

TF300-Q38F

3 m length flexible hose equipped with automatic female quick coupler at one end and male threading at the other end.

Q-M, Q-F

Quick couplers

standard version



Q14-MS

Q14-MS

Male automatic coupler for hydraulic heads (1/4" NPT).



Q38-F

Q38-F

Female automatic coupler with safety ring for hydraulic pumps and flexible hoses (3/8" NPT).



Q38-MS

Q38-MS

Male automatic coupler for flexible hoses (3/8" NPT).

I-F, I-M

insulated version



I38-F

I38-F

Female automatic coupler with safety ring for insulated hydraulic pumps and flexible hoses (3/8" NPT).



I38-MS

I38-MS

Male automatic coupler for insulated flexible hoses (3/8" NPT).

In this section of the catalogue you can find selected products at competitive price which complement our traditional range



Cable Ties in PA6.6

PA 6.6



HF HALOGEN FREE



Material: PA6.6 Polyamide
 Self-extinguishing V2 (UL 94)
 Humidity absorption:
 2,5% (at 50% relative humidity)
 Operating temperature:
 From -40°C to +85°C (continuous)
 From -40°C to +120°C (short periods)
 Resistant to:
 oils, greases, oil products, chlorinated solvents.
 Colour: Natural or Black (Ral 2005)

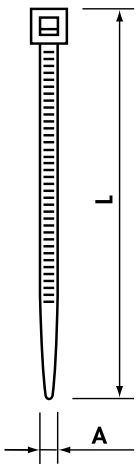

Black ties have higher UV resistance due to increased carbon black loading



Natural ties offer rapid installation due to the low friction coefficient of the material



Type	L (mm)	A (mm)	Max. Bundle Ø (mm)	Min. Loop Tensile Strength (kg)	Quantity	
G80X2.4	80	2,4	15	8	100	
G80X2.4N					1000	
G80X2.4/M			16		100	
G80X2.4N/M					1000	
G90X2.4	90	2,5	33		100	
G90X2.4N					1000	
G100X2.5			100		40	100
G100X2.5N						1000
G100X2.5/M	30	100				
G100X2.5N/M		1000				
G120X2.5	120	2,5	33	100		
G120X2.5N				1000		
G140X2.5			140	40	1000	
G140X2.5N					1000	
G140X2.5/M	53	100				
G140X2.5N/M		1000				
G160X2.5	160	2,8	65	100		
G160X2.5N				1000		
G160X2.5/M			76	1000		
G160X2.5N/M				1000		
G200X2.5	200	3,6	14	100		
G200X2.5N				1000		
G200X2.5/M			18	100		
G200X2.5N/M				1000		
G250X2.8	250	4,8	22	100		
G250X2.8N				1000		
G300X2.8			300	2,8	14	100
G300X2.8N						1000
G120X3.6	120	3,6			30	100
G120X3.6N						1000
G140X3.6			140	18	33	100
G140X3.6N						1000
G140X3.6/M	35	1000				
G140X3.6N/M		1000				
G150X3.6	150	3,6	44	100		
G150X3.6N				1000		
G180X3.6			180	22	53	100
G180X3.6N						1000
G200X3.6	200	4,8			76	1000
G200X3.6N						1000
G200X3.6/M			102	100		
G200X3.6N/M				1000		
G250X3.6	250	4,8	76	100		
G250X3.6N				1000		
G300X3.6			300	22	102	1000
G300X3.6N						1000
G300X3.6/M	110	1000				
G300X3.6N/M		1000				
G370X3.6	370	4,8	22	100		
G370X3.6N				1000		
G120X4.8	120	4,8	24	100		
G120X4.8N				1000		
G160X4.8			160	22	38	100
G160X4.8N						1000
G190X4.8	190	22			46	1000
G190X4.8N						1000
G190X4.8/M			50	1000		
G190X4.8N/M				1000		
G200X4.8	200	22	50	100		
G200X4.8N				1000		
G200X4.8/M			60	1000		
G200X4.8N/M				1000		
G250X4.8/M	250	22	60	1000		
G250X4.8N/M				1000		
G250X4.8			250	22	60	1000
G250X4.8N						1000
G280X4.8	280	22			70	1000
G280X4.8N						1000
G300X4.8			300	22	76	1000
G300X4.8N						1000
G370X4.8	370	22			102	1000
G370X4.8N						1000
G390X4.8			390	4,8	105	1000
G390X4.8N						1000
G430X4.8	430	4,8	110	1000		
G430X4.8N				1000		

Minimum order: 1,000 pcs

Minimum order: 100 pcs

Note: In Type, N = Black

Recommended tools are shown on page 246

The dimensions shown in the table must be considered as nominal. Cembre reserves the right to make changes without prior notice

CABLE TIES

G series, PA6.6 Polyamide

Cable Ties in PA6.6

Type	L (mm)	A (mm)	Max. Bundle Ø (mm)	Min. Loop Tensile Strength (kg)	Quantity			
G450X4.8	450	4,8	116	22	100			
G450X4.8N								
G530X4.8	530	4,8	140	22				
G530X4.8N								
G150X7.6	150	7,6	33	55				
G150X7.6N								
G200X7.6	200		50			50		
G200X7.6N								
G250X7.6	250		65			65		
G250X7.6N								
G300X7.6	300		76			76		
G300X7.6N								
G370X7.6	370		102			102		
G370X7.6N								
G430X7.6	430		125			125		
G430X7.6N								
G530X7.6	530		140			140		
G530X7.6N								
G430X9.0	430		9,0			110	80	
G430X9.0N								
G530X9.0	530					140		140
G530X9.0N								
G710X9.0	710					190		190
G710X9.0N								
G780X9.0	780				228	228		
G780X9.0N								
G830X9.0	830				239	239		
G830X9.0N								
G920X9.0	920	263		263				
G920X9.0N								
G1020X9.0	1020	295		295				
G1020X9.0N								
G1220X9.0	1220	365		365				
G1220X9.0N								
G230X12.6	230	12,6		50	115			
G230X12.6N								
G380X12.6	380			106		106		
G480X12.6								480
G480X12.6N								
G580X12.6	580			152		152		
G580X12.6N								
G730X12.6	730			204		204		
G730X12.6N								
G880X12.6	880		248	248				
G880X12.6N								
G1030X12.6	1030		295	295				
G1030X12.6N								

Note: In Type, N = Black

Recommended tools are shown on page 246

The dimensions shown in the table must be considered as nominal. Cembre reserves the right to make changes without prior notice

G

PA 6.6



HF
HALOGEN
FREE



Angled tongue to facilitate easy introduction into the buckle



Rounded corners for increased safety



CABLE TIES

G series, PA6.6 Polyamide - V0 (UL94)

Cable Ties in PA6.6 - V0 (UL94)

Type	L (mm)	A (mm)	Max. Bundle Ø (mm)	Min. Loop Tensile Strength (kg)	Quantity	Minimum Order Qty
G90X2.4 V0	90	2,4	16	8	100	1000
G100X2.5/M V0	100		22			
G140X2.5/M V0	140	2,5	33	18	1000	
G200X2.5/M V0	200		53			
G150X3.6 V0	150	3,6	35	100		
G200X4.8/M V0	200	4,8	50	22	1000	
G370X4.8 V0	370		102			
G430X4.8 V0	430	9,0	110	80	100	100
G710X9.0 V0	710		190			

Recommended tools are shown on page 246

The dimensions shown in the table must be considered as nominal. Cembre reserves the right to make changes without prior notice

G V0

PA 6.6



HF
HALOGEN
FREE

Same features as G series except: self-extinguishing V0 (UL 94)

CABLE TIES

GR series, PA6.6 Polyamide

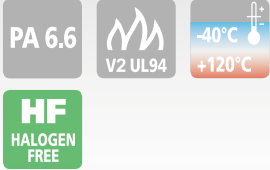

Same features as G series.
Easy installation without tools.
Released by pressure on the tongue.
Suitable for temporary locking.

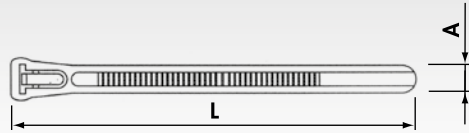

Releasable cable ties in PA6.6

Type	L (mm)	A (mm)	Max. Bundle Ø (mm)	Min. Loop Tensile Strength (kg)	Quantity
GR100X7.6N	100	7,6	20	22,2	100
GR120X7.6N	120		30		
GR150X7.6N	150		35		
GR200X7.6N	200		50		
GR250X7.6N	250		66		
GR300X7.6N	300		80		
GR370X7.6N	370		102		

Recommended tools are shown on page 246

The dimensions shown in the table must be considered as nominal. Cembre reserves the right to make changes without prior notice

CABLE TIES

GFH series, PA6.6 Polyamide



Same features as G series.
Quick and easy identification of bundled conductors.
Write on panel with Felt tip pen.

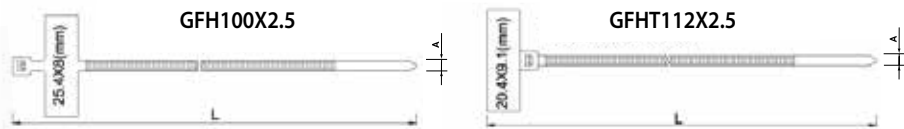

Markable cable ties in PA6.6

Type	L (mm)	A (mm)	Max. Bundle Ø (mm)	Min. Loop Tensile Strength (kg)	Quantity
GFH100X2.5	100	2,5	18	8,1	100
GFHT112X2.5	112				

Recommended tools are shown on page 246

The dimensions shown in the table must be considered as nominal. Cembre reserves the right to make changes without prior notice

CABLE TIES

1600 series, Elastomerized Polymer on Polyamide base



Resistant to: UV, salt atmosphere, oils, greases, oil products
Colour: Black

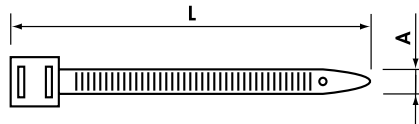

Material: Elastomerized Polymer on Polyamide base
Self-extinguishing HB (UL94)
Halogen free
Operating temperature:
From -45°C to +85°C (continuous)
From -45°C to +120°C (short periods)

Cable Ties in PA12 Polyamide

Type	Head Type	L (mm)	A (mm)	Min. Bundle Ø (mm)	Max. Bundle Ø (mm)	Min. Loop Tensile Strength (kg)	Quantity
1618.90	single	180	9	15	40	40	100
1626.90	double	260	9	30	60	55	100
1636.90	double	360	9	30	93	55	100
1651.90	double	510	9	70	140	55	100
1676.90	double	760	9	70	220	55	100

Recommended tools are shown on page 246

The dimensions shown in the table must be considered as nominal. Cembre reserves the right to make changes without prior notice

CABLE TIES

GX

GX series, in Stainless Steel AISI 304

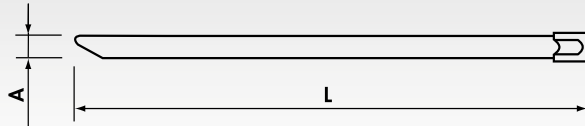

Cable Ties in Stainless Steel

Type	L (mm)	A (mm)	Max. Bundle Ø (mm)	Min. Loop Tensile Strength (kg)	Quantity
GX200X4.5	200	4,5	50	46	100
GX300X4.5	300		76		
GX370X4.5	370		102		
GX520X4.5	520		156		
GX370X7.9	370	7,9	102	114	
GX680X7.9	680		207		
GX1020X7.9	1020		312		

Recommended tools are shown on page 246

The dimensions shown in the table must be considered as nominal. Cembre reserves the right to make changes without prior notice

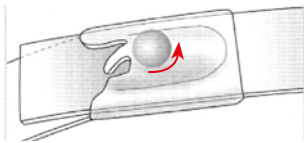

Insert the tongue into the buckle. The internal locking ball rolls freely as the tie is tightened.

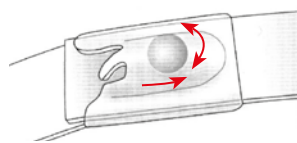

Once the correct tension is reached, use the specific tool to trim the tongue. The ball then wedges into the buckle locking it tightly against both the top and bottom of the tie.



Material: Stainless Steel AISI 304
 Unique ball locking mechanism that allows simple and rapid installation and secure locking.
 Operating temperature: From -80°C to +500°C
 High tensile strength.
 Non-flammability.
 High resistance to acetic acid, alkalis, sulphuric acid, corrosion, etc.
 In general very resistant to most hostile environments.

CABLE TIES

GXAC

GXAC series, 316 Stainless Steel coated with Polyester

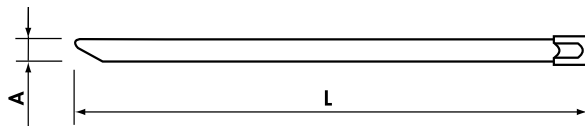

Coated Stainless Steel cable ties

Type	L (mm)	A (mm)	Max. Bundle Ø (mm)	Min. Loop Tensile Strength (kg)	Quantity
GXAC125X4.6	125	4,6	38,0	46	100
GXAC150X4.6	150		46,0		
GXAC200X4.6	200		61,9		
GXAC260X4.6	260		81,0		
GXAC290X4.6	290		90,6		
GXAC360X4.6	360		112,8		
GXAC520X4.6	520		163,8		
GXAC680X4.6	680		214,8		
GXAC840X4.6	840		265,7		
GXAC200X7.9	200		7,9		
GXAC290X7.9	290	90,6			
GXAC360X7.9	360	112,8			
GXAC520X7.9	520	163,8			
GXAC680X7.9	680	214,8			
GXAC840X7.9	840	265,7			

Recommended tools are shown on page 246

The dimensions shown in the table must be considered as nominal. Cembre reserves the right to make changes without prior notice

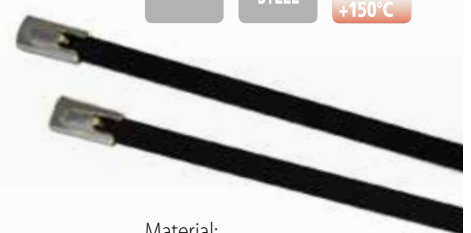

Material: 316 stainless steel for the most corrosive environments coated with Polyester for insulation purpose, and a better outdoor application
 Colour: Black
 Smooth surface and rounded edges assures cable protection and user safety
 Equipped with unique ball locking mechanism that allows simple and rapid installation and secure locking
 Operating temperature: da -40°C a +150°C
 High tensile strength
 Very resistant to ultraviolet radiation and chemical corrosion
 Non flammable

PA6.6 Polyamide

PA 6.6



Material: PA6.6 Polyamide
 Self-extinguishing V2 (UL 94)
 Humidity absorption:
 2,5% (at 50% relative humidity)
 Operating temperature:
 From -40°C to +85°C (continuous)
 From -40°C to +120°C (short periods)

Resistant to:
 oils, bases, greases, oil products, chlorinated solvents.
 Colour: Natural

Attention:
 acrylic adhesive; to obtain the best result, wait at least 6 - 8 hours before applying the load.

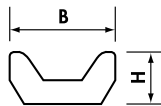
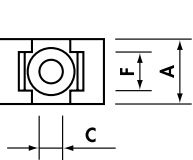
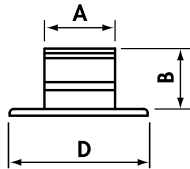
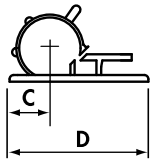
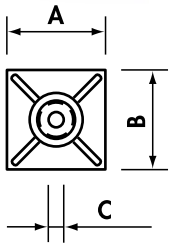

Self adhesive cable tie bases in PA6.6

Type	Max Tie (mm)	A (mm)	B (mm)	C (mm)	H (mm)	Fixing screw hole Ø (mm)	Quantity
AB13*	2,8	13,0	13,0	3,2	3,2	-	100
AB19*	3,6	19,0	19,0	4,0	4,4	3,1	100
AB28*	4,8	28,0	28,0	5,3	5,7	5,5	100

*Add to Ref: N for Black



Self adhesive cable clips in PA6.6

Type	Cable Ø (mm)	A (mm)	B (mm)	C (mm)	D (mm)	Quantity
CC8.9	8-9	9,0	12,0	8,0	21,5	100
CC9.12	9-12	12,0	15,0	8,2	21,5	100



Cable tie saddle clamps in PA6.6

Type	Max Tie (mm)	A (mm)	B (mm)	C (mm)	F (mm)	H (mm)	Quantity
SS4.8-3.7	4,8	9,5	15	3,7	5,0	7,2	100
SS4.8-4.5	4,8	9,5	15	4,5	5,0	7,2	100
SS9-4.5	9	16,0	22	4,5	9,2	9,7	100
SS9-5	9	16,0	22	5,0	9,2	9,7	100
SS9-6.4	9	16,0	22	6,4	9,2	9,7	100

GH8

ACCESSORIES

PA6.6 Polyamide

PA 6.6



Same features as G series.
 Push into Ø 8 mm hole.
 Cable tie inserted through slot in head.

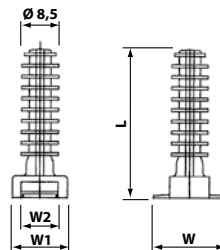

Stud fixing for cable ties in PA6.6

Type	W (mm)	W1 (mm)	W2 (mm)	L (mm)	Fixing hole Ø (mm)	Quantity
GH8	20	15	10	40,5	8	100

INSULATED COVERS

ES

For uninsulated connectors

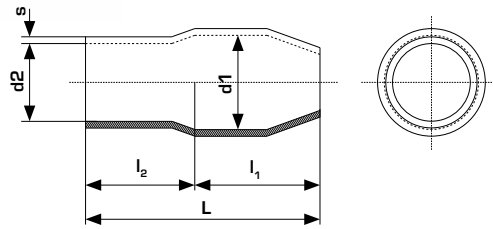

Insulated covers in PVC for general use with Cembre A-M copper tube lugs characterised by environmental tolerance, flexibility, not inflammability & stable performance. Widely used for the insulation and protection of connections and electrical terminations.

General features:

- Material: PVC
- Self extinguishing (UL94): V0
- Working temperature: 85 °C
- Colours: red, yellow, blue, black, grey, brown.

Type	Connectors A-M*	d1 Ø	d2 Ø	l1 ±1	l2 ±1	L ±2	s ±0.2	Quantity	Minimum Order Qty
ES03-..	A03	3.3	3.1	7.0	8.0	15.0	0.6	100	3,000
ES06-..	A06	4.5	3.7	8.0	8.0	16.0	0.7	100	
ES1-..	A1	5.7	4.1	9.0	9.0	18.0	0.8	100	
ES2-..	A2	7.2	6.2	11.0	10.0	21.0	1.0	100	1,000
ES3-..	A3	10.0	8.0	15.0	13.0	28.0	1.1	100	
ES5-..	A5	12.0	9.5	15.0	14.0	29.0	1.2	100	
ES10-..	A7, A9, A10	14.0	11.8	17.0	17.0	34.0	1.4	100	500
ES14-..	A12, A14	17.0	13.9	22.0	20.0	42.0	1.5	100	
ES19-..	A17, A19	19.0	16.0	25.0	21.0	46.0	1.5	50	
ES24-..	A20, A24	22.0	18.0	31.0	24.0	55.0	1.7	50	200
ES30-..	A29, A30	24.0	20.0	32.0	28.0	60.0	1.8	50	
ES37-..	A35, A37	26.0	22.0	34.0	31.0	65.0	1.8	50	
ES40-..	A40	32.2	24.0	38.0	31.0	69.0	2.0	50	100
ES48-..	A48	36.5	27.2	42.0	33.0	75.0	2.0	50	
ES80-..	A60, A80	36.7	30.0	42.0	33.0	75.0	2.0	25	

Add the suffix corresponding to the selected colour to the reference:

-BU blue, -GY grey, -BR brown, -BK black, -RE red, -YE yellow,

* See A-M type copper tube lugs on pages 28-29, 31

** Depending on the diameter of the insulated cable

flame-retardant Polyolefin - shrinkage ratio 2÷1



Heat-shrinkable Polyolefin tubing coil for general use; is environmentally neutral, flexible, not inflammable and offers fast heat shrinkage and stable performance.

Main uses include insulation and protection of electrical conductors, connectors and terminations; protection of metal tubes from corrosion; protection of antennae and various identification applications.

For general characteristics and technical specifications see page 242.

- Colours: Black, Red, White, Blue, Transparent, Yellow, Green, Grey, Brown, Yellow/Green.
- Packaging: Coil on Reel

Type	Coil Length	before shrinking		after shrinking		Colour
		Internal Ø mm	Internal Ø mm	Thickness mm	Colour	
TCS12X200BK	200 m	Ø 1,1 mm	Ø 0,50 mm	0,22 mm	BLACK	●
TCS16X200BK	200 m	Ø 1,5 mm	Ø 0,65 mm	0,28 mm	BLACK	●
TCS24X200BK	200 m	Ø 2,5 mm	Ø 1,00 mm	0,35 mm	BLACK	●
TCS32X200BK	200 m	Ø 3,0 mm	Ø 1,30 mm	0,38 mm	BLACK	●
TCS48X100BK	100 m	Ø 4,5 mm	Ø 2,00 mm	0,45 mm	BLACK	●
TCS64X100BK	100 m	Ø 6,5 mm	Ø 3,00 mm	0,55 mm	BLACK	●
TCS95X100BK	100 m	Ø 9,5 mm	Ø 4,50 mm	0,60 mm	BLACK	●
TCS127X100BK	100 m	Ø 12,5 mm	Ø 6,00 mm	0,60 mm	BLACK	●
TCS160X100BK	100 m	Ø 16,5 mm	Ø 8,00 mm	0,70 mm	BLACK	●
TCS190X100BK	100 m	Ø 19,0 mm	Ø 9,00 mm	0,80 mm	BLACK	●
TCS254X50BK	50 m	Ø 26,0 mm	Ø 12,5 mm	0,90 mm	BLACK	●
TCS320X50BK	50 m	Ø 31,5 mm	Ø 15,0 mm	0,95 mm	BLACK	●
TCS381X50BK	50 m	Ø 36,5 mm	Ø 17,5 mm	1,00 mm	BLACK	●
TCS508X25BK	25 m	Ø 50,0 mm	Ø 25,0 mm	1,00 mm	BLACK	●
TCS762X25BK	25 m	Ø 70,0 mm	Ø 36,0 mm	1,30 mm	BLACK	●
TCS1016X25BK	25 m	Ø 100,0 mm	Ø 51,0 mm	1,46 mm	BLACK	●
TCS1260X25BK	25 m	Ø 120,0 mm	Ø 61,0 mm	1,56 mm	BLACK	●
TCS1500X25BK	25 m	Ø 150,0 mm	Ø 76,0 mm	1,56 mm	BLACK	●
TCS16X200RE	200 m	Ø 1,5 mm	Ø 0,65 mm	0,28 mm	RED	●
TCS24X200RE	200 m	Ø 2,5 mm	Ø 1,00 mm	0,35 mm	RED	●
TCS32X200RE	200 m	Ø 3,0 mm	Ø 1,30 mm	0,38 mm	RED	●
TCS48X100RE	100 m	Ø 4,5 mm	Ø 2,00 mm	0,45 mm	RED	●
TCS64X100RE	100 m	Ø 6,5 mm	Ø 3,00 mm	0,55 mm	RED	●
TCS95X100RE	100 m	Ø 9,5 mm	Ø 4,50 mm	0,60 mm	RED	●
TCS127X100RE	100 m	Ø 12,5 mm	Ø 6,00 mm	0,60 mm	RED	●
TCS190X100RE	100 m	Ø 19,0 mm	Ø 9,00 mm	0,80 mm	RED	●
TCS254X50RE	50 m	Ø 26,0 mm	Ø 12,5 mm	0,90 mm	RED	●
TCS16X200WH	200 m	Ø 1,5 mm	Ø 0,65 mm	0,28 mm	WHITE	○
TCS20X200WH	200 m	Ø 2,0 mm	Ø 0,85 mm	0,32 mm	WHITE	○
TCS24X200WH	200 m	Ø 2,5 mm	Ø 1,00 mm	0,35 mm	WHITE	○
TCS32X200WH	200 m	Ø 3,0 mm	Ø 1,30 mm	0,38 mm	WHITE	○
TCS48X100WH	100 m	Ø 4,5 mm	Ø 2,00 mm	0,45 mm	WHITE	○
TCS64X100WH	100 m	Ø 6,5 mm	Ø 3,00 mm	0,55 mm	WHITE	○
TCS95X100WH	100 m	Ø 9,5 mm	Ø 4,50 mm	0,60 mm	WHITE	○
TCS127X100WH	100 m	Ø 12,5 mm	Ø 6,00 mm	0,60 mm	WHITE	○
TCS190X100WH	100 m	Ø 19,0 mm	Ø 9,00 mm	0,80 mm	WHITE	○
TCS254X50WH	50 m	Ø 26,0 mm	Ø 12,5 mm	0,90 mm	WHITE	○
TCS16X200BU	200 m	Ø 1,5 mm	Ø 0,65 mm	0,28 mm	BLUE	●
TCS24X200BU	200 m	Ø 2,5 mm	Ø 1,00 mm	0,35 mm	BLUE	●
TCS32X200BU	200 m	Ø 3,0 mm	Ø 1,30 mm	0,38 mm	BLUE	●
TCS48X100BU	100 m	Ø 4,5 mm	Ø 2,00 mm	0,45 mm	BLUE	●
TCS64X100BU	100 m	Ø 6,5 mm	Ø 3,00 mm	0,55 mm	BLUE	●
TCS95X100BU	100 m	Ø 9,5 mm	Ø 4,50 mm	0,60 mm	BLUE	●
TCS127X100BU	100 m	Ø 12,5 mm	Ø 6,00 mm	0,60 mm	BLUE	●
TCS190X100BU	100 m	Ø 19,0 mm	Ø 9,00 mm	0,80 mm	BLUE	●
TCS254X50BU	50 m	Ø 26,0 mm	Ø 12,5 mm	0,90 mm	BLUE	●
TCS381X50BU	50 m	Ø 36,5 mm	Ø 17,5 mm	1,00 mm	BLUE	●

TERMOCOIL HEAT-SHRINKABLE TUBING

TCS

flame-retardant Polyolefin - shrinkage ratio 2÷1

Type	Coil Length	before shrinking		after shrinking		Colour
		Internal Ø mm	Internal Ø mm	Thickness mm	Thickness mm	
TCS12X200TR	200 m	Ø 1,1 mm	Ø 0,50 mm	0,22 mm	TRANSPARENT	○
TCS16X200TR	200 m	Ø 1,5 mm	Ø 0,65 mm	0,28 mm	TRANSPARENT	○
TCS24X200TR	200 m	Ø 2,5 mm	Ø 1,00 mm	0,35 mm	TRANSPARENT	○
TCS32X200TR	200 m	Ø 3,0 mm	Ø 1,30 mm	0,38 mm	TRANSPARENT	○
TCS48X100TR	100 m	Ø 4,5 mm	Ø 2,00 mm	0,45 mm	TRANSPARENT	○
TCS64X100TR	100 m	Ø 6,5 mm	Ø 3,00 mm	0,55 mm	TRANSPARENT	○
TCS95X100TR	100 m	Ø 9,5 mm	Ø 4,50 mm	0,60 mm	TRANSPARENT	○
TCS127X100TR	100 m	Ø 12,5 mm	Ø 6,00 mm	0,60 mm	TRANSPARENT	○
TCS160X100TR	100 m	Ø 16,5 mm	Ø 8,00 mm	0,70 mm	TRANSPARENT	○
TCS190X100TR	100 m	Ø 19,0 mm	Ø 9,00 mm	0,80 mm	TRANSPARENT	○
TCS254X50TR	50 m	Ø 26,0 mm	Ø 12,5 mm	0,90 mm	TRANSPARENT	○
TCS320X50BK	50 m	Ø 31,5 mm	Ø 15,0 mm	0,95 mm	TRANSPARENT	○
TCS381X50TR	50 m	Ø 36,5 mm	Ø 17,5 mm	1,00 mm	TRANSPARENT	○
TCS508X25TR	25 m	Ø 50,0 mm	Ø 25,0 mm	1,00 mm	TRANSPARENT	○
TCS762X25TR	25 m	Ø 70,0 mm	Ø 36,0 mm	1,30 mm	TRANSPARENT	○
TCS1016X25TR	25 m	Ø 100,0 mm	Ø 51,0 mm	1,46 mm	TRANSPARENT	○
TCS1260X25TR	25 m	Ø 120,0 mm	Ø 61,0 mm	1,56 mm	TRANSPARENT	○
TCS1500X25TR	25 m	Ø 150,0 mm	Ø 76,0 mm	1,56 mm	TRANSPARENT	○
TCS16X200YE	200 m	Ø 1,5 mm	Ø 0,65 mm	0,28 mm	YELLOW	●
TCS24X200YE	200 m	Ø 2,5 mm	Ø 1,00 mm	0,35 mm	YELLOW	●
TCS32X200YE	200 m	Ø 3,0 mm	Ø 1,30 mm	0,38 mm	YELLOW	●
TCS48X100YE	100 m	Ø 4,5 mm	Ø 2,00 mm	0,45 mm	YELLOW	●
TCS64X100YE	100 m	Ø 6,5 mm	Ø 3,00 mm	0,55 mm	YELLOW	●
TCS95X100YE	100 m	Ø 9,5 mm	Ø 4,50 mm	0,60 mm	YELLOW	●
TCS127X100YE	100 m	Ø 12,5 mm	Ø 6,00 mm	0,60 mm	YELLOW	●
TCS190X100YE	100 m	Ø 19,0 mm	Ø 9,00 mm	0,80 mm	YELLOW	●
TCS254X50YE	50 m	Ø 26,0 mm	Ø 12,5 mm	0,90 mm	YELLOW	●
TCS16X200GN	200 m	Ø 1,5 mm	Ø 0,65 mm	0,28 mm	GREEN	●
TCS24X200GN	200 m	Ø 2,5 mm	Ø 1,00 mm	0,35 mm	GREEN	●
TCS32X200GN	200 m	Ø 3,0 mm	Ø 1,30 mm	0,38 mm	GREEN	●
TCS48X100GN	100 m	Ø 4,5 mm	Ø 2,00 mm	0,45 mm	GREEN	●
TCS64X100GN	100 m	Ø 6,5 mm	Ø 3,00 mm	0,55 mm	GREEN	●
TCS95X100GN	100 m	Ø 9,5 mm	Ø 4,50 mm	0,60 mm	GREEN	●
TCS127X100GN	100 m	Ø 12,5 mm	Ø 6,00 mm	0,60 mm	GREEN	●
TCS190X100GN	100 m	Ø 19,0 mm	Ø 9,00 mm	0,80 mm	GREEN	●
TCS254X50GN	50 m	Ø 26,0 mm	Ø 12,5 mm	0,90 mm	GREEN	●
TCS16X200GY	200 m	Ø 1,5 mm	Ø 0,65 mm	0,28 mm	GREY	●
TCS24X200GY	200 m	Ø 2,5 mm	Ø 1,00 mm	0,35 mm	GREY	●
TCS32X200GY	200 m	Ø 3,0 mm	Ø 1,30 mm	0,38 mm	GREY	●
TCS48X100GY	100 m	Ø 4,5 mm	Ø 2,00 mm	0,45 mm	GREY	●
TCS64X100GY	100 m	Ø 6,5 mm	Ø 3,00 mm	0,55 mm	GREY	●
TCS95X100GY	100 m	Ø 9,5 mm	Ø 4,50 mm	0,60 mm	GREY	●
TCS127X100GY	100 m	Ø 12,5 mm	Ø 6,00 mm	0,60 mm	GREY	●
TCS190X100GY	100 m	Ø 19,0 mm	Ø 9,00 mm	0,80 mm	GREY	●
TCS254X50GY	50 m	Ø 26,0 mm	Ø 12,5 mm	0,90 mm	GREY	●
TCS381X50GY	50 m	Ø 36,5 mm	Ø 17,5 mm	1,00 mm	GREY	●
TCS16X200BR	200 m	Ø 1,5 mm	Ø 0,65 mm	0,28 mm	BROWN	●
TCS24X200BR	200 m	Ø 2,5 mm	Ø 1,00 mm	0,35 mm	BROWN	●
TCS32X200BR	200 m	Ø 3,0 mm	Ø 1,30 mm	0,38 mm	BROWN	●
TCS48X100BR	100 m	Ø 4,5 mm	Ø 2,00 mm	0,45 mm	BROWN	●
TCS64X100BR	100 m	Ø 6,5 mm	Ø 3,00 mm	0,55 mm	BROWN	●
TCS95X100BR	100 m	Ø 9,5 mm	Ø 4,50 mm	0,60 mm	BROWN	●
TCS127X100BR	100 m	Ø 12,5 mm	Ø 6,00 mm	0,60 mm	BROWN	●
TCS190X100BR	100 m	Ø 19,0 mm	Ø 9,00 mm	0,80 mm	BROWN	●
TCS254X50BR	50 m	Ø 26,0 mm	Ø 12,5 mm	0,90 mm	BROWN	●
TCS381X50BR	50 m	Ø 36,5 mm	Ø 17,5 mm	1,00 mm	BROWN	●
TCS32X200Y/G	200 m	Ø 3,0 mm	Ø 1,30 mm	0,38 mm	YELLOW/GREEN	●
TCS48X100Y/G	100 m	Ø 4,5 mm	Ø 2,00 mm	0,45 mm	YELLOW/GREEN	●
TCS64X100Y/G	100 m	Ø 6,5 mm	Ø 3,00 mm	0,55 mm	YELLOW/GREEN	●
TCS95X100Y/G	100 m	Ø 9,5 mm	Ø 4,50 mm	0,60 mm	YELLOW/GREEN	●
TCS127X100Y/G	100 m	Ø 12,5 mm	Ø 6,00 mm	0,60 mm	YELLOW/GREEN	●
TCS190X100Y/G	100 m	Ø 19,0 mm	Ø 9,00 mm	0,80 mm	YELLOW/GREEN	●
TCS254X50Y/G	50 m	Ø 26,0 mm	Ø 12,5 mm	0,90 mm	YELLOW/GREEN	●
TCS381X50Y/G	50 m	Ø 36,5 mm	Ø 17,5 mm	1,00 mm	YELLOW/GREEN	●
TCS508X25Y/G	25 m	Ø 50,0 mm	Ø 25,0 mm	1,00 mm	YELLOW/GREEN	●





Heat-shrinkable Polyolefin tubing strip for general use; is environmentally neutral, flexible, not inflammable and offers fast heat shrinkage and stable performance.

Main uses include insulation and protection of electrical conductors, connectors and terminations; protection of metal tubes from corrosion; protection of antennae and various identification applications.

For general characteristics and technical specifications see page 242.

- Colours: Black, Red, White, Blue, Transparent, Yellow, Green, Grey, Brown, Yellow/Green.
- Packaging: Strips in Box

Type	Strip Length	before shrinking		after shrinking		Colour	Quantity Strips per box
		Internal Ø mm	Internal Ø mm	Thickness mm	Thickness mm		
TSS12BK	1,22 m	Ø 1,1 mm	Ø 0,5 mm	0,22 mm	0,22 mm	BLACK ●	30
TSS16BK	1,22 m	Ø 1,5 mm	Ø 0,65 mm	0,28 mm	0,28 mm	BLACK ●	30
TSS24BK	1,22 m	Ø 2,5 mm	Ø 1,00 mm	0,35 mm	0,35 mm	BLACK ●	30
TSS32BK	1,22 m	Ø 3,0 mm	Ø 1,30 mm	0,38 mm	0,38 mm	BLACK ●	30
TSS48BK	1,22 m	Ø 4,5 mm	Ø 2,00 mm	0,45 mm	0,45 mm	BLACK ●	30
TSS64BK	1,22 m	Ø 6,5 mm	Ø 3,00 mm	0,55 mm	0,55 mm	BLACK ●	30
TSS95BK	1,22 m	Ø 9,5 mm	Ø 4,50 mm	0,60 mm	0,60 mm	BLACK ●	20
TSS127BK	1,22 m	Ø 12,5 mm	Ø 6,00 mm	0,60 mm	0,60 mm	BLACK ●	15
TSS190BK	1,22 m	Ø 19,0 mm	Ø 9,00 mm	0,80 mm	0,80 mm	BLACK ●	10
TSS254BK	1,22 m	Ø 26,0 mm	Ø 12,5 mm	0,90 mm	0,90 mm	BLACK ●	6
TSS380BK	1,22 m	Ø 36,5 mm	Ø 17,5 mm	1,00 mm	1,00 mm	BLACK ●	4
TSS510BK	1,22 m	Ø 50,0 mm	Ø 25,0 mm	1,00 mm	1,00 mm	BLACK ●	2
TSS12RE	1,22 m	Ø 1,1 mm	Ø 0,5 mm	0,22 mm	0,22 mm	RED ●	30
TSS16RE	1,22 m	Ø 1,5 mm	Ø 0,65 mm	0,28 mm	0,28 mm	RED ●	30
TSS24RE	1,22 m	Ø 2,5 mm	Ø 1,00 mm	0,35 mm	0,35 mm	RED ●	30
TSS32RE	1,22 m	Ø 3,0 mm	Ø 1,30 mm	0,38 mm	0,38 mm	RED ●	30
TSS48RE	1,22 m	Ø 4,5 mm	Ø 2,00 mm	0,45 mm	0,45 mm	RED ●	30
TSS64RE	1,22 m	Ø 6,5 mm	Ø 3,00 mm	0,55 mm	0,55 mm	RED ●	30
TSS95RE	1,22 m	Ø 9,5 mm	Ø 4,50 mm	0,60 mm	0,60 mm	RED ●	20
TSS127RE	1,22 m	Ø 12,5 mm	Ø 6,00 mm	0,60 mm	0,60 mm	RED ●	15
TSS190RE	1,22 m	Ø 19,0 mm	Ø 9,00 mm	0,80 mm	0,80 mm	RED ●	10
TSS254RE	1,22 m	Ø 26,0 mm	Ø 12,5 mm	0,90 mm	0,90 mm	RED ●	6
TSS380RE	1,22 m	Ø 36,5 mm	Ø 17,5 mm	1,00 mm	1,00 mm	RED ●	4
TSS510RE	1,22 m	Ø 50,0 mm	Ø 25,0 mm	1,00 mm	1,00 mm	RED ●	2
TSS12WH	1,22 m	Ø 1,1 mm	Ø 0,5 mm	0,22 mm	0,22 mm	WHITE ○	30
TSS16WH	1,22 m	Ø 1,5 mm	Ø 0,65 mm	0,28 mm	0,28 mm	WHITE ○	30
TSS24WH	1,22 m	Ø 2,5 mm	Ø 1,00 mm	0,35 mm	0,35 mm	WHITE ○	30
TSS32WH	1,22 m	Ø 3,0 mm	Ø 1,30 mm	0,38 mm	0,38 mm	WHITE ○	30
TSS48WH	1,22 m	Ø 4,5 mm	Ø 2,00 mm	0,45 mm	0,45 mm	WHITE ○	30
TSS64WH	1,22 m	Ø 6,5 mm	Ø 3,00 mm	0,55 mm	0,55 mm	WHITE ○	30
TSS95WH	1,22 m	Ø 9,5 mm	Ø 4,50 mm	0,60 mm	0,60 mm	WHITE ○	20
TSS127WH	1,22 m	Ø 12,5 mm	Ø 6,00 mm	0,60 mm	0,60 mm	WHITE ○	15
TSS190WH	1,22 m	Ø 19,0 mm	Ø 9,00 mm	0,80 mm	0,80 mm	WHITE ○	10
TSS254WH	1,22 m	Ø 26,0 mm	Ø 12,5 mm	0,90 mm	0,90 mm	WHITE ○	6
TSS380WH	1,22 m	Ø 36,5 mm	Ø 17,5 mm	1,00 mm	1,00 mm	WHITE ○	4
TSS510WH	1,22 m	Ø 50,0 mm	Ø 25,0 mm	1,00 mm	1,00 mm	WHITE ○	2
TSS12BU	1,22 m	Ø 1,1 mm	Ø 0,5 mm	0,22 mm	0,22 mm	BLUE ●	30
TSS16BU	1,22 m	Ø 1,5 mm	Ø 0,65 mm	0,28 mm	0,28 mm	BLUE ●	30
TSS24BU	1,22 m	Ø 2,5 mm	Ø 1,00 mm	0,35 mm	0,35 mm	BLUE ●	30
TSS32BU	1,22 m	Ø 3,0 mm	Ø 1,30 mm	0,38 mm	0,38 mm	BLUE ●	30
TSS48BU	1,22 m	Ø 4,5 mm	Ø 2,00 mm	0,45 mm	0,45 mm	BLUE ●	30
TSS64BU	1,22 m	Ø 6,5 mm	Ø 3,00 mm	0,55 mm	0,55 mm	BLUE ●	30
TSS95BU	1,22 m	Ø 9,5 mm	Ø 4,50 mm	0,60 mm	0,60 mm	BLUE ●	20
TSS127BU	1,22 m	Ø 12,5 mm	Ø 6,00 mm	0,60 mm	0,60 mm	BLUE ●	15
TSS190BU	1,22 m	Ø 19,0 mm	Ø 9,00 mm	0,80 mm	0,80 mm	BLUE ●	10
TSS254BU	1,22 m	Ø 26,0 mm	Ø 12,5 mm	0,90 mm	0,90 mm	BLUE ●	6
TSS380BU	1,22 m	Ø 36,5 mm	Ø 17,5 mm	1,00 mm	1,00 mm	BLUE ●	4
TSS510BU	1,22 m	Ø 50,0 mm	Ø 25,0 mm	1,00 mm	1,00 mm	BLUE ●	2
TSS12TR	1,22 m	Ø 1,1 mm	Ø 0,5 mm	0,22 mm	0,22 mm	TRANSPARENT ○	30
TSS16TR	1,22 m	Ø 1,5 mm	Ø 0,65 mm	0,28 mm	0,28 mm	TRANSPARENT ○	30
TSS24TR	1,22 m	Ø 2,5 mm	Ø 1,00 mm	0,35 mm	0,35 mm	TRANSPARENT ○	30
TSS32TR	1,22 m	Ø 3,0 mm	Ø 1,30 mm	0,38 mm	0,38 mm	TRANSPARENT ○	30
TSS48TR	1,22 m	Ø 4,5 mm	Ø 2,00 mm	0,45 mm	0,45 mm	TRANSPARENT ○	30
TSS64TR	1,22 m	Ø 6,5 mm	Ø 3,00 mm	0,55 mm	0,55 mm	TRANSPARENT ○	30
TSS95TR	1,22 m	Ø 9,5 mm	Ø 4,50 mm	0,60 mm	0,60 mm	TRANSPARENT ○	20
TSS127TR	1,22 m	Ø 12,5 mm	Ø 6,00 mm	0,60 mm	0,60 mm	TRANSPARENT ○	15
TSS190TR	1,22 m	Ø 19,0 mm	Ø 9,00 mm	0,80 mm	0,80 mm	TRANSPARENT ○	10
TSS254TR	1,22 m	Ø 26,0 mm	Ø 12,5 mm	0,90 mm	0,90 mm	TRANSPARENT ○	6
TSS380TR	1,22 m	Ø 36,5 mm	Ø 17,5 mm	1,00 mm	1,00 mm	TRANSPARENT ○	4
TSS510TR	1,22 m	Ø 50,0 mm	Ø 25,0 mm	1,00 mm	1,00 mm	TRANSPARENT ○	2

TERMOSTRIP HEAT-SHRINKABLE TUBING

TSS

flame-retardant Polyolefin - shrinkage ratio 2÷1

Type	Strip Length	before shrinking		after shrinking		Colour	Quantity Strips per box
		Internal Ø mm	Internal Ø mm	Thickness mm	Internal Ø mm		
TSS12YE	1,22 m	Ø 1,1 mm	Ø 0,5 mm	0,22 mm	Ø 0,5 mm	YELLOW	30
TSS16YE	1,22 m	Ø 1,5 mm	Ø 0,65 mm	0,28 mm	Ø 0,65 mm	YELLOW	30
TSS24YE	1,22 m	Ø 2,5 mm	Ø 1,00 mm	0,35 mm	Ø 1,00 mm	YELLOW	30
TSS32YE	1,22 m	Ø 3,0 mm	Ø 1,30 mm	0,38 mm	Ø 1,30 mm	YELLOW	30
TSS48YE	1,22 m	Ø 4,5 mm	Ø 2,00 mm	0,45 mm	Ø 2,00 mm	YELLOW	30
TSS64YE	1,22 m	Ø 6,5 mm	Ø 3,00 mm	0,55 mm	Ø 3,00 mm	YELLOW	30
TSS95YE	1,22 m	Ø 9,5 mm	Ø 4,50 mm	0,60 mm	Ø 4,50 mm	YELLOW	20
TSS127YE	1,22 m	Ø 12,5 mm	Ø 6,00 mm	0,60 mm	Ø 6,00 mm	YELLOW	15
TSS190YE	1,22 m	Ø 19,0 mm	Ø 9,00 mm	0,80 mm	Ø 9,00 mm	YELLOW	10
TSS254YE	1,22 m	Ø 26,0 mm	Ø 12,5 mm	0,90 mm	Ø 12,5 mm	YELLOW	6
TSS380YE	1,22 m	Ø 36,5 mm	Ø 17,5 mm	1,00 mm	Ø 17,5 mm	YELLOW	4
TSS510YE	1,22 m	Ø 50,0 mm	Ø 25,0 mm	1,00 mm	Ø 25,0 mm	YELLOW	2
TSS12GN	1,22 m	Ø 1,1 mm	Ø 0,5 mm	0,22 mm	Ø 0,5 mm	GREEN	30
TSS16GN	1,22 m	Ø 1,5 mm	Ø 0,65 mm	0,28 mm	Ø 0,65 mm	GREEN	30
TSS24GN	1,22 m	Ø 2,5 mm	Ø 1,00 mm	0,35 mm	Ø 1,00 mm	GREEN	30
TSS32GN	1,22 m	Ø 3,0 mm	Ø 1,30 mm	0,38 mm	Ø 1,30 mm	GREEN	30
TSS48GN	1,22 m	Ø 4,5 mm	Ø 2,00 mm	0,45 mm	Ø 2,00 mm	GREEN	30
TSS64GN	1,22 m	Ø 6,5 mm	Ø 3,00 mm	0,55 mm	Ø 3,00 mm	GREEN	30
TSS95GN	1,22 m	Ø 9,5 mm	Ø 4,50 mm	0,60 mm	Ø 4,50 mm	GREEN	20
TSS127GN	1,22 m	Ø 12,5 mm	Ø 6,00 mm	0,60 mm	Ø 6,00 mm	GREEN	15
TSS190GN	1,22 m	Ø 19,0 mm	Ø 9,00 mm	0,80 mm	Ø 9,00 mm	GREEN	10
TSS254GN	1,22 m	Ø 26,0 mm	Ø 12,5 mm	0,90 mm	Ø 12,5 mm	GREEN	6
TSS380GN	1,22 m	Ø 36,5 mm	Ø 17,5 mm	1,00 mm	Ø 17,5 mm	GREEN	4
TSS510GN	1,22 m	Ø 50,0 mm	Ø 25,0 mm	1,00 mm	Ø 25,0 mm	GREEN	2
TSS12GY	1,22 m	Ø 1,1 mm	Ø 0,5 mm	0,22 mm	Ø 0,5 mm	GREY	30
TSS16GY	1,22 m	Ø 1,5 mm	Ø 0,65 mm	0,28 mm	Ø 0,65 mm	GREY	30
TSS24GY	1,22 m	Ø 2,5 mm	Ø 1,00 mm	0,35 mm	Ø 1,00 mm	GREY	30
TSS32GY	1,22 m	Ø 3,0 mm	Ø 1,30 mm	0,38 mm	Ø 1,30 mm	GREY	30
TSS48GY	1,22 m	Ø 4,5 mm	Ø 2,00 mm	0,45 mm	Ø 2,00 mm	GREY	30
TSS64GY	1,22 m	Ø 6,5 mm	Ø 3,00 mm	0,55 mm	Ø 3,00 mm	GREY	30
TSS95GY	1,22 m	Ø 9,5 mm	Ø 4,50 mm	0,60 mm	Ø 4,50 mm	GREY	20
TSS127GY	1,22 m	Ø 12,5 mm	Ø 6,00 mm	0,60 mm	Ø 6,00 mm	GREY	15
TSS190GY	1,22 m	Ø 19,0 mm	Ø 9,00 mm	0,80 mm	Ø 9,00 mm	GREY	10
TSS254GY	1,22 m	Ø 26,0 mm	Ø 12,5 mm	0,90 mm	Ø 12,5 mm	GREY	6
TSS380GY	1,22 m	Ø 36,5 mm	Ø 17,5 mm	1,00 mm	Ø 17,5 mm	GREY	4
TSS510GY	1,22 m	Ø 50,0 mm	Ø 25,0 mm	1,00 mm	Ø 25,0 mm	GREY	2
TSS12BR	1,22 m	Ø 1,1 mm	Ø 0,5 mm	0,22 mm	Ø 0,5 mm	BROWN	30
TSS16BR	1,22 m	Ø 1,5 mm	Ø 0,65 mm	0,28 mm	Ø 0,65 mm	BROWN	30
TSS24BR	1,22 m	Ø 2,5 mm	Ø 1,00 mm	0,35 mm	Ø 1,00 mm	BROWN	30
TSS32BR	1,22 m	Ø 3,0 mm	Ø 1,30 mm	0,38 mm	Ø 1,30 mm	BROWN	30
TSS48BR	1,22 m	Ø 4,5 mm	Ø 2,00 mm	0,45 mm	Ø 2,00 mm	BROWN	30
TSS64BR	1,22 m	Ø 6,5 mm	Ø 3,00 mm	0,55 mm	Ø 3,00 mm	BROWN	30
TSS95BR	1,22 m	Ø 9,5 mm	Ø 4,50 mm	0,60 mm	Ø 4,50 mm	BROWN	20
TSS127BR	1,22 m	Ø 12,5 mm	Ø 6,00 mm	0,60 mm	Ø 6,00 mm	BROWN	15
TSS190BR	1,22 m	Ø 19,0 mm	Ø 9,00 mm	0,80 mm	Ø 9,00 mm	BROWN	10
TSS254BR	1,22 m	Ø 26,0 mm	Ø 12,5 mm	0,90 mm	Ø 12,5 mm	BROWN	6
TSS380BR	1,22 m	Ø 36,5 mm	Ø 17,5 mm	1,00 mm	Ø 17,5 mm	BROWN	4
TSS510BR	1,22 m	Ø 50,0 mm	Ø 25,0 mm	1,00 mm	Ø 25,0 mm	BROWN	2
TSS12Y/G	1,22 m	Ø 1,1 mm	Ø 0,5 mm	0,22 mm	Ø 0,5 mm	YELLOW/GREEN	30
TSS16Y/G	1,22 m	Ø 1,5 mm	Ø 0,65 mm	0,28 mm	Ø 0,65 mm	YELLOW/GREEN	30
TSS24Y/G	1,22 m	Ø 2,5 mm	Ø 1,00 mm	0,35 mm	Ø 1,00 mm	YELLOW/GREEN	30
TSS32Y/G	1,22 m	Ø 3,0 mm	Ø 1,30 mm	0,38 mm	Ø 1,30 mm	YELLOW/GREEN	30
TSS48Y/G	1,22 m	Ø 4,5 mm	Ø 2,00 mm	0,45 mm	Ø 2,00 mm	YELLOW/GREEN	30
TSS64Y/G	1,22 m	Ø 6,5 mm	Ø 3,00 mm	0,55 mm	Ø 3,00 mm	YELLOW/GREEN	30
TSS95Y/G	1,22 m	Ø 9,5 mm	Ø 4,50 mm	0,60 mm	Ø 4,50 mm	YELLOW/GREEN	20
TSS127Y/G	1,22 m	Ø 12,5 mm	Ø 6,00 mm	0,60 mm	Ø 6,00 mm	YELLOW/GREEN	15
TSS190Y/G	1,22 m	Ø 19,0 mm	Ø 9,00 mm	0,80 mm	Ø 9,00 mm	YELLOW/GREEN	10
TSS254Y/G	1,22 m	Ø 26,0 mm	Ø 12,5 mm	0,90 mm	Ø 12,5 mm	YELLOW/GREEN	6
TSS380Y/G	1,22 m	Ø 36,5 mm	Ø 17,5 mm	1,00 mm	Ø 17,5 mm	YELLOW/GREEN	4





Heat-shrinkable Polyolefin tubing for general use; is environmentally neutral, flexible, not inflammable and offers fast heat shrinkage and stable performance.

Main uses include insulation and protection of electrical conductors, connectors and terminations; protection of metal tubes from corrosion; protection of antennae and various identification applications.

General characteristics:

- Operating temperature: -55°C + 125°C
- Minimum shrinkage temperature: 70°C
- Temperature for complete shrinkage: 110°C
- RoHS compliant
- Colours: Black, Red, White, Blue, Grey, Brown, Yellow/Green.
- Packaging: Roll in Dispenser Box

Technical Specifications:

Property	Test Method	Performance
Traction resistance (MPa):	ASRM D2671	≥10.4
Elongation at failure (%):	ASRM D2671	≥200
Traction resistance after heat aging (MPa):	UL 224 158°Cx168hr	≥7.3
Elongation at failure after heat aging (%):	UL 224 158°Cx168hr	≥100
Heat resistance:	UL 224 250°Cx4hr	No failure
Low temperature flexibility:	UL 224 -30°Cx4hr	No failure
Dielectric strength (kv/mm):	IEC 243	≥15
Insulation resistance:	600V UL 224	No perforation at 2500V
Volume resistance (Ω.cm):	IEC 93	≥1x10 ¹⁴
Corrosive action:	UL 224 158°Cx168hr	Not corrosive
Copper compatibility:	UL 224 158°Cx168hr	Not corrosive
Flammability:	UL 224	VW-1

Type	Reel Length	before shrinking		after shrinking		Colour
		Internal Ø mm	Internal Ø mm	Thickness mm	Thickness mm	
TBS16X20BK	20 m	Ø 1,5 mm	Ø 0,65 mm	0,28 mm	0,28 mm	BLACK ●
TBS24X20BK	20 m	Ø 2,5 mm	Ø 1,00 mm	0,35 mm	0,35 mm	BLACK ●
TBS32X10BK	10 m	Ø 3,0 mm	Ø 1,30 mm	0,38 mm	0,38 mm	BLACK ●
TBS48X10BK	10 m	Ø 4,5 mm	Ø 2,00 mm	0,45 mm	0,45 mm	BLACK ●
TBS64X10BK	10 m	Ø 6,5 mm	Ø 3,00 mm	0,55 mm	0,55 mm	BLACK ●
TBS95X10BK	10 m	Ø 9,5 mm	Ø 4,50 mm	0,60 mm	0,60 mm	BLACK ●
TBS127X10BK	10 m	Ø 12,5 mm	Ø 6,00 mm	0,60 mm	0,60 mm	BLACK ●
TBS190X5BK	5 m	Ø 19,0 mm	Ø 9,00 mm	0,80 mm	0,80 mm	BLACK ●
TBS254X5BK	5 m	Ø 26,0 mm	Ø 12,5 mm	0,90 mm	0,90 mm	BLACK ●
TBS16X20RE	20 m	Ø 1,5 mm	Ø 0,65 mm	0,28 mm	0,28 mm	RED ●
TBS24X20RE	20 m	Ø 2,5 mm	Ø 1,00 mm	0,35 mm	0,35 mm	RED ●
TBS32X10RE	10 m	Ø 3,0 mm	Ø 1,30 mm	0,38 mm	0,38 mm	RED ●
TBS48X10RE	10 m	Ø 4,5 mm	Ø 2,00 mm	0,45 mm	0,45 mm	RED ●
TBS64X10RE	10 m	Ø 6,5 mm	Ø 3,00 mm	0,55 mm	0,55 mm	RED ●
TBS95X10RE	10 m	Ø 9,5 mm	Ø 4,50 mm	0,60 mm	0,60 mm	RED ●
TBS127X10RE	10 m	Ø 12,5 mm	Ø 6,00 mm	0,60 mm	0,60 mm	RED ●
TBS190X5RE	5 m	Ø 19,0 mm	Ø 9,00 mm	0,80 mm	0,80 mm	RED ●
TBS254X5RE	5 m	Ø 26,0 mm	Ø 12,5 mm	0,90 mm	0,90 mm	RED ●
TBS16X20WH	20 m	Ø 1,5 mm	Ø 0,65 mm	0,28 mm	0,28 mm	WHITE ○
TBS24X20WH	20 m	Ø 2,5 mm	Ø 1,00 mm	0,35 mm	0,35 mm	WHITE ○
TBS32X20WH	10 m	Ø 3,0 mm	Ø 1,30 mm	0,38 mm	0,38 mm	WHITE ○
TBS48X10WH	10 m	Ø 4,5 mm	Ø 2,00 mm	0,45 mm	0,45 mm	WHITE ○
TBS64X10WH	10 m	Ø 6,5 mm	Ø 3,00 mm	0,55 mm	0,55 mm	WHITE ○
TBS95X10WH	10 m	Ø 9,5 mm	Ø 4,50 mm	0,60 mm	0,60 mm	WHITE ○
TBS127X10WH	10 m	Ø 12,5 mm	Ø 6,00 mm	0,60 mm	0,60 mm	WHITE ○
TBS190X5WH	5 m	Ø 19,0 mm	Ø 9,00 mm	0,80 mm	0,80 mm	WHITE ○
TBS254X5WH	5 m	Ø 26,0 mm	Ø 12,5 mm	0,90 mm	0,90 mm	WHITE ○
TBS16X20BU	20 m	Ø 1,5 mm	Ø 0,65 mm	0,28 mm	0,28 mm	BLUE ●
TBS24X20BU	20 m	Ø 2,5 mm	Ø 1,00 mm	0,35 mm	0,35 mm	BLUE ●
TBS32X10BU	10 m	Ø 3,0 mm	Ø 1,30 mm	0,38 mm	0,38 mm	BLUE ●
TBS48X10BU	10 m	Ø 4,5 mm	Ø 2,00 mm	0,45 mm	0,45 mm	BLUE ●
TBS64X10BU	10 m	Ø 6,5 mm	Ø 3,00 mm	0,55 mm	0,55 mm	BLUE ●
TBS95X10BU	10 m	Ø 9,5 mm	Ø 4,50 mm	0,60 mm	0,60 mm	BLUE ●
TBS127X10BU	10 m	Ø 12,5 mm	Ø 6,00 mm	0,60 mm	0,60 mm	BLUE ●
TBS190X5BU	5 m	Ø 19,0 mm	Ø 9,00 mm	0,80 mm	0,80 mm	BLUE ●
TBS254X5BU	5 m	Ø 26,0 mm	Ø 12,5 mm	0,90 mm	0,90 mm	BLUE ●

Type	Reel Length	before shrinking		after shrinking		Colour
		Internal Ø mm	Internal Ø mm	Thickness mm	Thickness mm	
TBS16X20GY	20 m	Ø 1,5 mm	Ø 0,65 mm	0,28 mm	0,28 mm	GREY ●
TBS24X20GY	20 m	Ø 2,5 mm	Ø 1,00 mm	0,35 mm	0,35 mm	GREY ●
TBS32X10GY	10 m	Ø 3,0 mm	Ø 1,30 mm	0,38 mm	0,38 mm	GREY ●
TBS48X10GY	10 m	Ø 4,5 mm	Ø 2,00 mm	0,45 mm	0,45 mm	GREY ●
TBS64X10GY	10 m	Ø 6,5 mm	Ø 3,00 mm	0,55 mm	0,55 mm	GREY ●
TBS95X10GY	10 m	Ø 9,5 mm	Ø 4,50 mm	0,60 mm	0,60 mm	GREY ●
TBS127X10GY	10 m	Ø 12,5 mm	Ø 6,00 mm	0,60 mm	0,60 mm	GREY ●
TBS190X5GY	5 m	Ø 19,0 mm	Ø 9,00 mm	0,80 mm	0,80 mm	GREY ●
TBS254X5GY	5 m	Ø 26,0 mm	Ø 12,5 mm	0,90 mm	0,90 mm	GREY ●
TBS16X20BR	20 m	Ø 1,5 mm	Ø 0,65 mm	0,28 mm	0,28 mm	BROWN ●
TBS24X20BR	20 m	Ø 2,5 mm	Ø 1,00 mm	0,35 mm	0,35 mm	BROWN ●
TBS32X10BR	10 m	Ø 3,0 mm	Ø 1,30 mm	0,38 mm	0,38 mm	BROWN ●
TBS48X10BR	10 m	Ø 4,5 mm	Ø 2,00 mm	0,45 mm	0,45 mm	BROWN ●
TBS64X10BR	10 m	Ø 6,5 mm	Ø 3,00 mm	0,55 mm	0,55 mm	BROWN ●
TBS95X10BR	10 m	Ø 9,5 mm	Ø 4,50 mm	0,60 mm	0,60 mm	BROWN ●
TBS127X10BR	10 m	Ø 12,5 mm	Ø 6,00 mm	0,60 mm	0,60 mm	BROWN ●
TBS190X5BR	5 m	Ø 19,0 mm	Ø 9,00 mm	0,80 mm	0,80 mm	BROWN ●
TBS254X5BR	5 m	Ø 26,0 mm	Ø 12,5 mm	0,90 mm	0,90 mm	BROWN ●
TBS16X20Y/G	20 m	Ø 1,5 mm	Ø 0,65 mm	0,28 mm	0,28 mm	YELLOW/GREEN ●
TBS24X20Y/G	20 m	Ø 2,5 mm	Ø 1,00 mm	0,35 mm	0,35 mm	YELLOW/GREEN ●
TBS32X10Y/G	10 m	Ø 3,0 mm	Ø 1,30 mm	0,38 mm	0,38 mm	YELLOW/GREEN ●
TBS48X10Y/G	10 m	Ø 4,5 mm	Ø 2,00 mm	0,45 mm	0,45 mm	YELLOW/GREEN ●
TBS64X10Y/G	10 m	Ø 6,5 mm	Ø 3,00 mm	0,55 mm	0,55 mm	YELLOW/GREEN ●
TBS95X10Y/G	10 m	Ø 9,5 mm	Ø 4,50 mm	0,60 mm	0,60 mm	YELLOW/GREEN ●
TBS127X10Y/G	10 m	Ø 12,5 mm	Ø 6,00 mm	0,60 mm	0,60 mm	YELLOW/GREEN ●
TBS190X5Y/G	5 m	Ø 19,0 mm	Ø 9,00 mm	0,80 mm	0,80 mm	YELLOW/GREEN ●
TBS254X5Y/G	5 m	Ø 26,0 mm	Ø 12,5 mm	0,90 mm	0,90 mm	YELLOW/GREEN ●

cast resin, low voltage through joints

Shells

Manufactured from transparent synthetic material which allows a visual check of the connections before and after casting.

The halves of the shell are joined by snap closures which avoid further fixing or sealing.

Shells are left on after casting to provide additional protection against mechanical abrasion, chemical agents and severe weather conditions.



STRAIGHT JOINTS

Type	Dimensions mm				Dimensions Cable	
	L	H	D1(1)	D2(1)	Cable Diameter mm	Indicative Cable Section (2) mm ²
N11	200	50	8	26	8 - 25	4C x 1,5 ÷ 10
N12	260	67	16	32	16 - 31	4C x 10 ÷ 25
N13	360	75	21	38	21 - 36	4C x 35 ÷ 50
N14	400	100	26	41	26 - 39	4C x 50 ÷ 70
N15	530	130	35	56	35 - 54	4C x 95 ÷ 150
N16	700	150	47	74	45 - 72	4C x 185 ÷ 300

(1) Internal dimension of the shell

(2) Indicative cable sections are approximate and concern only harmonised, PVC or Rubber insulated cables at a working voltage of 0,6/1 kV

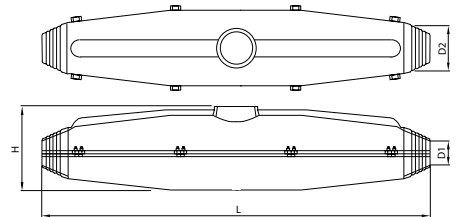

BRANCH JOINTS

Type	Dimensions mm					Dimensions Cable		
	L	H	B	D1(1)	D2(1)	Cable Diameter mm	Indicative Cable Section (2) mm ²	
							Passante	Derivato
NY00	150	47	70	11	20	11 - 20	4C x 1,5 ÷ 2,5	4C x 1,5
NY0	175	60	94	6	22	6 - 21	4C x 4 ÷ 10	4C x 4
NY1	225	75	110	9	26	9 - 24	4C x 6 ÷ 25	4C x 16

(1) Internal dimension of the shell

(2) Indicative cable sections are approximate and concern only harmonised, PVC or Rubber insulated cables at a working voltage of 0,6/1 kV

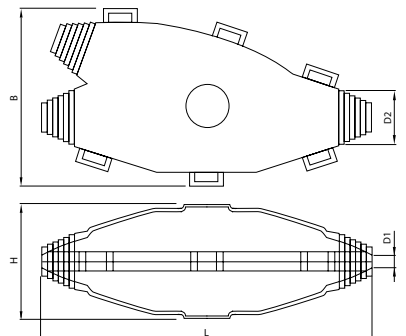

Cast resin technology

PUR-cast resin technology was introduced to seal and protect power, signal and telephone cable joints.

This new generation of two component cast resin has been developed for the most demanding environments and circumstances.

Cembre cast resin joints meet the requirements of EN50393 and DIN VDE 57291-2 (VDE0291).

Quick setting properties in humid or even cold conditions make it a fast and reliable solution.

No external measuring or mixing is required as this takes place within an Aluminium foil pouch, avoiding spillage and errors during installation.

Unmixed resin components have a 48 month shelf-life even in the most difficult storage conditions.

Shells are made of durable PET resulting in good hydrophobic properties and excellent impact resistance, while good adhesion to PVC and metals assures a watertight seal.

Technical characteristic	Test result	Requirement of DIN VDE 0291
Pot life @ 5°C 23°C 35°C	35 min 20 min 15 min	product conforms ± 30%
Reactant open cup flash point	> 200 °C	> 55
Tensile strength	≥ 8.0 Mpa	≥ 5.0
Hot aging	-5 Shore A	-7
Adhesive	> 1500 CP.S	-
Elongation at break	≥ 100%	≥ 50%
Gel time for 300 ml @ Pouch >1000 ml Pouch <1000 ml	23 °C 26 min 17 min	product conforms ± 10% product conforms ± 10%
Max. reaction temp.	60 °C / 333 K	product conforms ± 10%
Total vol. variability when hardening	6 %	max. 6.5 %
Cast resin component open cup flash point	> 200 °C	> 100
Density	1.07 g / cm ³	-
Impact strength	> 10 kJ / m ²	> 10 kJ / m ²
Hardness	75 Shore A	min. 20 Shore D
Expansion coefficient in temp. range 20-50°C	5.9 x 10 ⁻⁴ K ⁻¹	product conforms ± 15%
Thermal conductivity	0.2W x m ⁻¹ x K ⁻¹	product conforms ± 20%
Flammability	Class II c	acc. to DIN VDE 0304, part 3
Water absorption 42 days@50°C	360 mg	max. 400 mg
Electrolytic corrosion	A1	-
Voltage test @ 23°C 80°C	> 20 kV > 10 kV	no breakdown @ test voltage > 20 kV > 20 kV
Dielectric dissipation factor @ 23°C and 50 Hz 23°C and 1k Hz	0.08 0.05	max. 0.1 -
Relative permittivity @ 23°C and 50 Hz @ 23°C and 1k Hz	5 5.1	< 6 -
Tracking resistance	KA 3c	min KA 3c
After 28 days of immersion in 90°C water		
Tensile strength	8.2N/mm ²	≥ 65% of initial value
Elongation at break	60%	≥ 65% of initial value
Hardness	47 Shore	≥ 80% of initial value

MECHANICAL TOOLS

ML

MARKETline range

MARKETline



TECHNICAL FEATURES

Crimping Range	For crimping insulated terminals, 0,25 to 6 sqmm side insertion
Dimensions mm	
Length	252
Width	78
Height	23
Weight g	556



MLL1



TECHNICAL FEATURES

Crimping Range	Single aperture, ratchet controlled tool for crimping female connectors, open barrel, flag type 1 to 2,5 sqmm - side insertion
Dimensions mm	
Length	252
Width	78
Height	23
Weight g	558



MLL90



TECHNICAL FEATURES

Crimping Range	For crimping end sleeves 0,25 to 6 sqmm
Dimensions mm	
Length	198
Width	77
Height	18
Weight g	350



MLS1

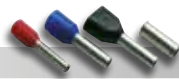

TECHNICAL FEATURES

Crimping Range	For crimping end sleeves 6 to 16 sqmm
Dimensions mm	
Length	198
Width	77
Height	18
Weight g	350



MLS2

TECHNICAL FEATURES

Crimping Range	For crimping insulated and uninsulated connectors, 0,25 to 6 sqmm
Dimensions mm	
Length	234
Width	65
Height	15
Weight g	228



ZP2

HB

MECHANICAL TOOLS

MARKETline range

TECHNICAL FEATURES

Application Range	Wire stripper, for PVC insulated cables 0,25 to 6 sqmm
Dimensions mm	
Length	166
Width	55
Height	15
Weight g	134



HB5

TECHNICAL FEATURES

Application Range	A versatile tool for cutting, crimping, and stripping. Range: 0,2 to 6 sqmm
Dimensions mm	
Length	206
Width	106
Height	21
Weight g	256



HB7

TECHNICAL FEATURES

Application Range	Wire stripper, for PVC insulated cables 0,2 to 6 sqmm
Dimensions mm	
Length	175
Width	90
Height	22
Weight g	200

MARKETline



HB8

CABLE TIE TOOLS

TECHNICAL FEATURES

Application Range	For plastic cable ties from 2,2 to 4,8 mm
Dimensions mm	
Length	162
Width	133
Height	23
Weight g	208



5313022048

Automatic cutting

TECHNICAL FEATURES

Application Range	For stainless steel cable ties width up to 7,9 mm
Dimensions mm	
Length	180
Width	141
Height	30
Weight g	558



5527030079

With cutting device

TECHNICAL FEATURES

Application Range	For plastic cable ties from 4,8 to 9 mm
Dimensions mm	
Length	194
Width	100
Height	25
Weight g	324



5523036090

Manual cutting

FLS

TAPE RULES

FLS3 3 metres long
FLS5 5 metres long

Robust metal case with comfortable ergonomic shape and protective mouldings for professional use. Nylon coated tape for long-life corrosion and abrasion resistance.

End hook magnet for increased user convenience. Self-locking on extension, double release button for controlled retraction.



















































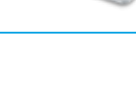





















- FLS3 Weight : 166 g – Tape width : 16 mm
 - FLS5 Weight : 252 g – Tape width : 19 mm
- Supplied in individual blister or as a display of 12 units for FLS3 and FLS5



DIE SELECTOR CHART



DIE SELECTOR CHART

	APPLICATION	CONDUCTOR		CONNECTOR				HYDRAULIC TOOLS							
								B15MD		HT45-E B450ND-BV		HT51 RH50 B500 B500ND B550			
								DIE SET	NEST	INDEN- TOR	DIE SET	NEST	INDEN- TOR	DIE SET	
		Conductor Size sqmm		TERMINAL		SPLICE	DIE SET	NEST	INDEN- TOR	DIE SET	NEST	INDEN- TOR	DIE SET		
		Low Str.	Flex												
COPPER CONDUCTORS		0,25 ÷ 2,5	A 03-M. A 06-M.				L 03-M / L 03-P L 06-M / L 06-P	ME03/2-15 							
			4 ÷ 6	A 1-M. A 1-L.				L 1-M L 1-P	ME03/2-15  MA03/3-15 	MA1 	PA1	ME1 	MA1-50 	PA1-50	ME1-50 
		10		A 2-M. A 2-L. A 2-P12 A 2-U.		A 2-2M.		L 2-M L 2-P	ME03/2-15  ME2/3-15  MA03/3-15 	MA2.3 	PA5	ME2 	MA2.3-50 	PA5-50	ME2-50 
			16	A 3-M. A 3-L. A 3-P14 A 3-P22R. A 3-U.		A 3-2M.	2A 3-M.	L 3-M L 3-P	ME2/3-15  MA03/3-15 			MA5 			PA10
		25		A 5-M. A 5-L. A 5-P16 A 5-P22R.		A 5-2M.	2A 5-M.	L 5-M L 5-P		MA7 	PA10		ME5 	MA5-50 	
			35	25*	A 7-M. A 7-L. A 7-P20	A 7-2M.	2A 7-M.	L 7-M L 7-P				MA10 	PA10		ME7 
		50		35*	A 10-M. A 10-L. A 10-P25	A 10-2M.	2A 10-M.	2A10-2M.	L 10-M L 10-P		MA10 			PA10	ME10 
			70	50*	A 14-M. A 14-L. A 14-P30	A 14-2M.	2A 14-M.	2A14-2M.	L 14-M L 14-P			MA10 	PA10		ME14 
		95		70*	A 19-M. A 19-L.	A 19-2M.	2A 19-M.	2A19-2M.	L 19-M L 19-P		MA10 			PA10	ME19 
			120	95*	A 24-M. A 24-L.	A 24-2M.	2A 24-M.	2A24-2M.	L 24-M L 24-P			MA10 	PA10		ME24 
		150		120*	A 30-M. A 30-L.	A 30-2M.	2A 30-M.	2A30-2M.	L 30-M L 30-P		MA10 			PA10	ME30 
			185	150*	A 37-M. A 37-L. A 37-4ESI	A 37-2M.	2A 37-M.	2A37-2M.	L 37-M L 37-P			MA10 	PA10		
		240		185*	A 48-M. A 48-L. A 48-4ESI	A 48-2M.	2A 48-M.	2A48-2M.	L 48-M L 48-P		MA10 			PA10	
			300	240	A 60-M. A 60-L. A 60-4ESI	A 60-2M.	2A 60-M.	2A60-2M.	L 60-M L 60-P			MA10 	PA10		
		400		300	A 80-M. A 80-L. A 80-4ESI	A 80-2M.	2A 80-M.	2A80-2M.	L 80-M		MA10 			PA10	
			500	400	A 100-M. A 100-4ESI	A 100-2M.	2A 100-M.	2A100-2M.	L 100-M			MA10 	PA10		
		630		500	A 120-M. A 120-4ESI	A 120-2M.	2A 120-M.	2A120-2M.	L 120-M		MA10 			PA10	
			800	630	A 160-M. A 160-4ESI	A 160-2M.	2A 160-M.	2A160-2M.	L 160-M			MA10 	PA10		
		1000		800	A 200-M.	A 200-2M.	2A 200-M.	2A200-2M.	L 200-M		MA10 			PA10	
			35		A 9-M.							MA9 	PA10		ME9 
	50			A 12-M.						MA9 	PA10			ME12 	MA12-50 
		70		A 17-M.								MA9 	PA10	ME17 	MA17-50 
	95			A 20-M.						MA9 	PA10			ME20 	MA20-50 
		120		A 29-M.								MA9 	PA10	ME29 	MA29-50 
	150			A 35-M.						MA9 	PA10			ME35 	MA35-50 
		185		A 40-M.								MA9	PA10	ME40 	MA40-50

 = Hexagonal crimp (use one size up with fine stranded conductors, E.G.: 95* fine stranded use A19.. + ME 19 or A 20.. + ME 20)

* Contact Cembre for appropriate die set

 = Indent crimp

DIE SELECTOR CHART

HYDRAULIC TOOLS																	
HT61 RH61 B600 [◇]			HT 81-U RHU 81		HT 120 and tools and heads with 130 kN crimping force			ECW-H3D			RHU 520						
NEST	INDEN- TOR	DIE SET	NEST AND INDENTOR	DIE SET	NEST	INDEN- TOR	DIE SET	NEST	INDENTOR	DIE SET	NEST	INDENTOR	DIE SET				
MA1-50	PA1-50	ME1-50															
MA2.3-60	PA5-50	ME2-50	MA3.5-U	ME2.19-U	MA2-C	PA10-C	ME2-C	Adaptor AU230-130D with die set MA...-C and indentor PA...-C	Adaptor AU230-130D with die set ME...-C	Adaptor AU520-130C with die set MA...-C and indentor PA...-C	Adaptor AU 520-130 C with die set ME...-C						
		ME3-50		ME3.14-U			MA3-C					ME3-C					
		ME5-50		ME5.7-U			MA5-C					ME5-C					
MA7-50	ME7-50	MA7.14-U	MA7-C		ME7-C												
MA10-50	PA10-50	ME10-50	MA10.19-U	ME10.24-U	MA10-C	PA24-C	ME10-C										
MA14-50	PA19-50	ME14-50	MA7.14-U	ME3.14-U	MA14-C		ME14-C										
MA19-50		ME17-50	MA10.19-U MA19-U	ME2.19-U	MA19-C		ME19-C										
MA24-50	PA24-50	ME24-50		MA24-U	ME10.24-U	MA24-C	PA48-C					ME24-C					
		ME30-50	MA30.80-U	ME30-U	MA30-C	ME30-C											
		ME37-50	MA37-U	ME37-U	MA37-C	ME37-C											
		ME48-50	MA48-U	ME48-U	MA48-C	ME48-C											
					MA60-C	PA60-C	ME60-C										
							ME80-C					MA80-3D	PA100-3D	ME80-3D	MA80-520	PA120-520	ME80-520
												MA100-3D		ME100-3D	MA100-520		ME100-520
								MA120-3D	PA120-3D	ME120-3D	MA120-520	ME120-520					
											MA160-520	PA200-520	ME160-520				
											MA200-520		ME200-520				
			MA9.17-U	ME9.20-U	MA9-C	PA10-C	ME9-C	Adaptor AU 230-130 D with die set MA...-C and indentor PA...-C	Adaptor AU 230-130 D with die set ME...-C	Adaptor AU520-130C with die set MA...-C and indentor PA...-C	Adaptor AU 520-130 C with die set ME...-C						
			MA12.20-U	ME12.17-U	MA12-C	PA24-C	ME12-C										
			MA9.17-U	ME12.17-U	MA17-C		ME17-C										
			MA12.20-U	ME9.20-U	MA20-C	ME20-C											
			MA29.80-U	ME29-U	MA29-C	PA48-C	ME29-C										
			MA35-U	ME35-U	MA35-C		ME35-C										
			MA40-U	ME40-U	MA40-C		ME40-C										

N.B.: Number inside symbol indicates the number of crimps on A-M barrel ** Only for B500, B500ND and RH50.

[◇] The tools type HT 61, RH 61 and B600 use the same dies as the HT51 with a spring type 6522051.

DIE SELECTOR CHART

APPLICATION	CONDUCTOR	CONNECTOR					
COPPER CONDUCTORS   	Conductor Size Flex sqmm	TERMINAL					
	10	ANE2-M..	ANE2-P12	ANE2-U..			
	16	ANE3-M..	ANE3-P14	ANE3-U..			
	25	ANE5-M..	ANE5-P16				
	35	ANE7-M..	ANE7-P20				
	50	ANE10-M..					
	70	ANE14-M..					
	95	ANE19-M..					
	120	ANE24-M..					
	150	ANE30-M..					
EXTRA FLEXIBLE COPPER CONDUCTORS 	35	ANE9-M..					
	50	ANE12-M..					
	70	ANE17-M..					
	95	ANE20-M..					
	120	ANE29-M..					
	150	ANE35-M..					
COPPER CONDUCTORS  	Conductor Size Flex sqmm	TERMINAL					
	0,3 ÷ 4	PKD506÷PKD418	PKE508÷PKE418	PKC508÷PKC418	KE506÷KE412		
	4 ÷ 16	PKD410÷PKD1618	PKE410÷PKE1618	PKC410÷PKC1618	KE410÷KE1616		
	16	PKD16..	PKE16..	PKC16..	KE16..		
	25	PKD25..	PKE25..	PKC25..	KE25..		
	35	PKD35..		PKC35..	KE35..		
	50	PKD50..		PKC50..			
	70			PKC70..			
	95			PKC95..			
	120			PKC120..			
	Conductor Size Flex sqmm	TERMINAL					
	2 x 0,5	PKT508 PKT510					
	2 x 0,75	PKT7508 PKT7510					
	2 x 1	PKT108 PKT110					
	2 x 1,5	PKT1508 PKT1512					
	2 x 2,5	PKT2510 PKT2512					
	2 x 4	PKT412					
	2 x 6	PKT614					
	2 x 10	PKT1014					
	2 x 16	PKT1614					







 = Indent crimp
  = Radial crimp
  = Trapezium crimp

DIE SELECTOR CHART

HYDRAULIC TOOLS									
B15MD	HT45-E B450ND-BV	HT51 RH50 B500 B500ND B550	HT61 RH61 B600 [◇]	HT 120 and tools and heads with 130 kN crimping force			ECW-H3D		
DIE SET		DIE SET		NEST	INDENTOR	DIE SET	NEST	INDENTOR	
NN4-15		MN2RF-50	MN2RF-50	MN2-C	PN7-C	MN2RF-C	Adaptor AU230-130D with die set MN...-C and indentor PN...-C or with die set MN...-RF-C and die set MN...-F-C		
		MN3RF-50	MN3RF-50	MN3-C		MN3RF-C			
		MN5RF-50	MN5RF-50	MN5-C		MN5RF-C			
		MN7RF-50	MN7RF-50	MN7-C		MN7RF-C			
		MN10RF-50	MN10RF-50	MN10-C	PN14-C	MN10RF-C			
		MN14RF-50	MN14RF-50	MN14-C		MN14RF-C			
		MN19RF-50	MN19RF-50	MN19-C	PN24-C	MN19RF-C			
		MN24RF-50	MN24RF-50	MN24-C		MN24RF-C			
					MN30-C	PN37-C		MN30RF-C	
		MN7RF-50		MN9-C	PN14-C	MN7RF-C	Adaptor AU230-130D with die set MN...-C and indentor PN...-C or with die set MN...-RF-C and die set MN...-F-C		
		MN12F-50		MN12-C		MN12F-C			
		MN17F-50		MN17-C	PN24-C	MN17F-C			
		MN20F-50		MN20-C		MN20F-C			
				MN29-C	PN37-C	MN29F-C			
				MN35-C		MN35F-C			
DIE SET		DIE SET							
KE4-15									
KE16-15									
KE35-15		MTT16-50							
		MTT25-50							
		MTT35-50							
		MTT50-50							
		MTT70-50							
		MTT95-50							
		MTT120-50							
DIE SET	COMP. APERTURE	DIE SET							
KE4-15	1								
	1,5								
	2,5								
	2,5								
KE4-15	4								
KE16-15	6								
KE16-15	10								
KE16-15	16	MTT16-50							
KE35-15	35	MTT35-50							

[◇] The tools type HT 61, RH 61 and B600 use the same dies as the HT51 with a spring type 6S22051.

DIE SELECTOR CHART



APPLICATION	CONDUCTOR		CONNECTOR				HT45-E B450ND-BV	HT51 RH50 B500 B500ND B550	HT61 RH61 B600	HT 81-U RHU 81	HT 120 and tools and heads with 130 kN crimping force	ECW-H3D	RHU520						
	Conductor Size sqmm	Tap	CONNECTOR	CONNECTOR	CONNECTOR	DIE SET								DIE SET	DIE SET	DIE SET	DIE SET	DIE SET	DIE SET
			Run	CONDUCTOR	CONDUCTOR	CONDUCTOR								DIE SET	DIE SET	DIE SET	DIE SET	DIE SET	DIE SET
TAP-OFF ON COPPER CONDUCTOR  C-C-ST  C-C	6 ÷ 2.5	6 ÷ 1.5	C6-C6ST	C6-C6		MC6	MC6-50	MC6-50	MC6.25-U										
	10	10 ÷ 1.5	C10-C10ST	C10-C10		MC10	MC10-50	MC10-50	MC10-U	MC10-C									
	16	16 ÷ 1.5	C16-C16ST	C16-C16					MC6.25-U	MC25-C	Adaptor AU230-130D with die set MC-C								
	25 ÷ 16	10 ÷ 1.5	C25-C10ST	C25-C10					MC25-U	MC35-C									
	25	25 ÷ 16	C25-C25ST	C25-C25															
	40 ÷ 35	16 ÷ 1.5	C35-C16ST	C35-C16															
	40 ÷ 35	40 ÷ 25	C35-C35ST	C35-C35															
	50	25 ÷ 10																	
	70 ÷ 63	25 ÷ 1.5	C70-C25NST	C70-C25N															
	50	25 ÷ 4	C50-C25ST	C50-C25															
	*50	50 ÷ 35	C50-C50ST	C50-C50															
	*70 ÷ 50	40 ÷ 4	C70-C35ST	C70-C35															
	*70 ÷ 50	70 ÷ 35	C70-C70ST	C70-C70															
	100 ÷ 95	40 ÷ 4	C95-C35ST	C95-C35															
	100 ÷ 95	70 ÷ 40	C95-C70ST	C95-C70															
	100 ÷ 95	100 ÷ 63	C95-C95ST	C95-C95															
	125 ÷ 110	125 ÷ 25	C120-C120ST	C120-C120															
	160 ÷ 150	125 ÷ 25	C150-C120ST	C150-C120															
	125	125																	
	150	150 ÷ 63																	
125	125																		
185	100 ÷ 16																		
185 ÷ 120	185 ÷ 120																		
240 ÷ 150	120 ÷ 95																		
H.V. COPPER CONDUCTORS  MT-7D  MT-6C  CA-M  CA-3M  MT-C	25 R	MT25-TD	MT25-GC	CA25-M..	CA25-2M..	MT25-C..	DIE SET												
	35 RC/35 ÷ 40 S	MT40S-TD	MT40S-GC	CA40S-M..	CA40S-2M..	MT40S-C..	MMT25-50	MMT25-50	MMT25-U	MMT25-C									
	50 RC	MT50R-TD	MT50R-GC	CA50R-M..	CA50R-2M..	MT50R-C..	MMT50-50	MMT50-50	MMT50-U	MMT50-C									
	50 S	MT50S-TD	MT50S-GC	CA50S-M..	CA50S-2M..	MT50S-C..													
	63 S ÷ 70 S	MT70S-TD	MT70S-GC	CA70S-M..	CA70S-2M..	MT70S-C..													
	80 S ÷ 95 RC	MT95R-TD	MT95R-GC	CA95R-M..	CA95R-2M..	MT95R-C..													
	95 S ÷ 100 S	MT95S-TD	MT95S-GC	CA95S-M..	CA95S-2M..	MT95S-C..													
	120 RC/S ÷ 150 RC	MT150R-TD	MT150R-GC	CA150R-M..	CA150R-2M..	MT150R-C..													
	150 S ÷ 180 RC	MT150S-TD	MT150S-GC	CA150S-M..	CA150S-2M..	MT150S-C..													
	160 S ÷ 200 RC	MT200R-TD	MT200R-GC	CA200R-M..	CA200R-2M..	MT200R-C..													
	200 S ÷ 240 RC	MT240R-TD	MT240R-GC	CA240R-M..	CA240R-2M..	MT240R-C..													
	240 S ÷ 315 RC	MT315R-TD	MT315R-GC	CA315R-M..	CA315R-2M..	MT315R-C..													
	315 S	MT315S-TD	MT315S-GC	CA315S-M..	CA315S-2M..	MT315S-C..													
	400 R	MT400-TD		2A80-M..	2A80-2M..							ME80-C							
	500 R	MT500-TD		2A100-M..	2A100-2M..							ME100-3D							
	600 R ÷ 630 R	MT630-TD		2A120-M..	2A120-2M..							ME120-3D							
													ME80-520						
													ME100-520						
													ME120-520						

◊ The tools type HT 61, RH 61 and B600 use the same dies as the HT 51 with a spring type 632051.

* When using die set type MC70-50, the conductors marked with a star must be annealed.

○ = circular crimp
 ○ = oval crimp
 ◊ = hexagonal crimp

DIE SELECTOR CHART FOR DEEP STEPPED INDENTING WITH CONTAINING DIES

APPLICATION	CONDUCTOR	CONNECTOR			HYDRAULIC TOOLS				
		Conductor Size sqmm	LUGS	MTA	DIE HOLDER	DIE		INDENTOR	
						HT 131-UC	RHU 131-C		B1350-UC
 CAA-M.  MTA-C	10	CAA10-M..			AU130-150	MV35	MUA35	PS130-35/E	
	16	CAA16-M..	MTA16-C			MV95	MUA95	PS130-95/E	
	25	CAA25-M..	MTA25-C			MV150	MUA150	PS130-150/E	
	35	CAA35-M..	MTA35-C			MV240	MUA240	PS130-240/E	
	50	CAA50-M..	MTA50-C			MUA300-34			
	70	CAA70-M..	MTA70-C..						
	95	CAA95-M..	MTA95-C..						
	120	CAA120-M..	MTA120-C..						
	150	CAA150-M..	MTA150-C..						
	185	CAA185-M..	MTA185-C..						
240	CAA240-M..	MTA240-C..							
300	CAA300-34M..								
 AA-M.	16	AA16-M..			AU130-150				
	25	AA25-M..							
	35	AA35-M..							
	50	AA50-M..							
	70	AA70-M..							
	95	AA95-M..							
	120	AA120-M..							
	150	AA150-M..							
	185	AA185-M..							
	240	AA240-M..							
300	AA300-34M..								

ALUMINIUM CONDUCTORS

 = Deep indent crimp

DIE SELECTOR CHART FOR DEEP STEPPED INDENTING WITH CONTAINING DIES

Conductor Size sqmm		SPLICE		Conductor Size sqmm Al/Cu		SPICES		DIE HOLDER		DIE		INDENTOR	
10	MTMA10-GC	MTMA16/1	16	10	MTMA16-10GC					MVM35	MUA35		PS130-35/E
16	MTMA16-GC	MTMA25/1	25	10	MTMA25-10GC								
25	MTMA25-GC		25	16	MTMA25-16GC								
35	MTMA35-GC	MTMA35/1											
50	MTMA50-GC	MTMA50/1	50	25	MTMA50-25GC								
			50	35	MTMA50-35GC								
70	MTMA70-GC	MTMA70/1	70	35	MTMA70-35GC								
			70	50	MTMA70-50GC								
95	MTMA95-GC	MTMA95/1	95	50	MTMA95-50GC								
			95	70	MTMA95-70GC								
120	MTMA120-GC	MTMA120/1	120	70	MTMA120-70GC								
			120	95	MTMA120-95GC								
150	MTMA150-GC	MTMA150/1	150	70	MTMA150-70GC								
			150	95	MTMA150-95GC								
185	MTMA185-GC	MTMA185/1	185	120	MTMA150-120GC								
			185	150	MTMA185-150GC								
240	MTMA240-GC	MTMA240/1	240	150	MTMA240-150GC								
			240	185	MTMA240-185GC								
300	MTMAD300-GC	MTMAD300/1	300	185	MTMAD300-185GC								
			300	240	MTMAD300-240GC								





ALUMINIUM CONDUCTORS

= Deep indent crimp

PRE-ROUNDERS SELECTION		DIE-SUPPORT		DIES DESCRIPTION		DIES SEQUENCE	
ALUMINIUM CONDUCTOR SIZE sqmm	PRE-ROUNDER	DIE-SUPPORT				CONDUCTOR ROUNDING	CRIMPING
25				1) AU 130... DIE HOLDER Used to house dies and pre-rounders.			
35		AC 130-P		2) UP 130... PRE-ROUNDERS Used to round aluminium sectoral conductors in order to introduce them into circular connectors. Each pre-rounder is made of two parts: the upper part is housed in die-holder AU 130... and the lower part is locked onto AC 130-P die support.			
50				3) AC 130-P DIE SUPPORT Houses lower part of pre-rounder UP 130...			
70				4) MUA... DIES Containing dies.			
95				5) PS 130...-E INDENTORS Such indentors are specifically engineered for deep indentation of aluminium conductors of any stranding configuration.			
120							
150							
185							
240							

DIE SELECTOR CHART

APPLICATION	CONDUCTOR	CONNECTOR		B15MD DIE SET	HT45-E B450ND-BV DIE SET	HT51 RH50 B500 B500ND B550 DIE SET		HT120 and tools and heads with 130 kN crimping force		ECW-H3D		RHU520	
		LUGS	SPICES			HT51 RH50 B500 B500ND B550 DIE SET	HT120 and tools and heads with 130 kN crimping force	NEST	INDENTOR	NEST	INDENTOR		
 O. DIN 46234	6-10	Q10..				MQ10-50	MQ10-50	MQM10-C				Adaptor AU520-130C with die set MQ...	
	10-16	Q16..				MQ16-50	MQ16-50	MQM16-C	MQS16-C				
	16-25	Q25..				MQ25-50	MQ25-50	MQM25-C	MQS25-C				
	25-35	Q35..				MQ35-50	MQ35-50	MQM35-C	MQS35-C				
	35-50	Q50..				MQ50-50	MQ50-50	MQM50-C	MQS50-C				
	50-70	Q70..				MQ70-50	MQ70-50	MQM70-C	MQS70-C				
	70-95	Q95..						MQM95-C	MQS95-C				
	95-120	Q120..						MQM120-C	MQS120-C				
	120-150	Q150..						MQM150-C	MQS150-C				
	150-185	Q185..						MQM185-C	MQS185-C				
	185-240	Q240..						MQM240-C	MQS240-C				
	6	DR6..		DSV6	MK5		MK5-50	MK5-50	MK5-C				Adaptor AU520-130C with die set MK...-C
	10	DR10..		DSV10	MK5/8-15		MK6-50	MK6-50	MK6-C				
	16	DR16..		DSV16	MK8		MK8-50	MK8-50	MK8-C				
	25	DR25..		DSV25	MK10		MK10-50	MK10-50	MK10-C				
	35	DR35..		DSV35	MK12		MK12-50	MK12-50	MK12-C				
	50	DR50..		DSV50	MK14		MK14-50	MK14-50	MK14-C				
	70	DR70..		DSV70	MK16		MK16-50	MK16-50	MK16-C				
95	DR95..		DSV95	MK18		MK18-50	MK18-50	MK18-C					
120	DR120..		DSV120	MK20		MK20-50	MK20-50	MK20-C					
150	DR150..		DSV150	MK22L		MK22-50	MK22-50	MK22-C					
185	DR185..		DSV185			MK25-50	MK25-50	MK25-C					
240	DR240..		DSV240			MK28-50	MK28-50	MK28-C					
300	DR300..		DSV300			MK32-50*	MK32-50	MK32-C					
400	DR400..		DSV400										
500	DR500..		DSV500										
625	DR625..		DSV625										
800	DR800..		DSV800										
1000	DR1000..		DSV1000										
 HR.. DIN 46235 - 46267 T.1	10	HR10..	HSV10	MH10		MH10-50	MH10-50	MH10-C			Adaptor AU520-130C with die set MH...-C		
	16	HR16..	HSV16	MH16		MH16-50	MH16-50	MH16-C					
	25	HR25..	HSV25	MH25		MH25-50	MH25-50	MH25-C					
	35	HR35..	HSV35	MH35		MH35-50	MH35-50	MH35-C					
	50	HR50..	HSV50	MH50		MH50-50	MH50-50	MH50-C					
	70	HR70..	HSV70	MH70		MH70-50	MH70-50	MH70-C					
	95	HR95..	HSV95	MH95		MH95-50	MH95-50	MH95-C					
	120	HR120..	HSV120	MH120		MH120-50	MH120-50	MH120-C					
	150	HR150..	HSV150	MH150		MH150-50	MH150-50	MH150-C					
	185	HR185..	HSV185			MH185-50	MH185-50	MH185-C					
	240	HR240..	HSV240			MH240-50	MH240-50	MH240-C					
	300	HR300..	HSV300			MH300-50*	MH300-50	MH300-C					
	400							MH400-C					
	500							MH500-3D					
	630							MH630-3D					

= Indent crimp
 = Hexagonal crimp
 NB: for through connectors this is the number of crimps per conductor
 * Only for B500, B500ND and RH50
 ◇ Tools type HT 81-U and RHU 81 with adaptor type 6780232 can use the same dies of HT 51 but are equipped with spring type 6522051
 ◇ The tools type HT 61, RH 61 and B600 use the same dies as the HT 51 with a spring type 6522051.

DIE SELECTOR CHART

APPLICATION	CONDUCTOR		CONNECTOR		HYDRAULIC TOOLS					
	Conductor Size sqmm	Conductor Size AWG	LUGS	SPLICE	HT 120 and tools and heads with 130 kN crimping force		HT 51 RH50 B500 B500ND			
					B15MD DIE SET	DIE SET	DIE SET	DIE SET		
C...	10	8	C8..	BSCL8			MY2-50 (1)	MY2-C (1)	ECW-H3D DIE SET	RHU520 DIE SET
CL...	16	6	C6..	BSCL6			MY3-50 (1)	MY3-C (1)		
CL...	25	4	C4..	BSCL4			MY4-50 (1)	MY4-C (1)		
CL...	35	3	C3..	BSCL3			MY5-50 (1)	MY5-C (1)		
CL...	50	2	C2..	BSCL2			MY6-50 (1)	MY6-C (1)		
CL...	70	1	C1..	BSCL1			MY7-50 (1)	MY7-C (1)		
CL...	95	1/0	C1/0.	BSCL1/0			MY10-50 (2)	MY10-C (1)		
CL...	120	2/0	C2/0.	BSCL2/0			MY14-50 (2)	MY14-C (1)		
CL...	150	3/0	C3/0.	BSCL3/0			MY16-50 (2)	MY16-C (1)		
CL...	185	4/0	C4/0.	BSCL4/0			MY19-50 (2)	MY19-C (1)		
BSCL	240	250 MCM	C250..	BSCL250			MY24-50 (2)	MY24-C (1)		
BSCL	300	300 MCM	C300..	BSCL300			MY30-50 (2)	MY30-C (1)		
BSCL	350	350 MCM	C350..	BSCL350			MY36-50 (2)	MY36-C (1)		
BSCL	400	400 MCM	C400..	BSCL400			MY37-50 (2)	MY37-C (1)		
BSCL	500	500 MCM	C500..	BSCL500			MY48-50 (3)	MY48-C (2)		
BSCL	600	600 MCM	C600..	BSCL600			MY60-C (2)	MY60-C (2)		
BSCL	750	750 MCM	C750..	BSCL750			MY76-C (2)	MY76-C (2)		







































N.B.: Number inside symbol indicates the number of crimps for C short barrel lugs only.

○ = Circular crimp ◐ = Indent crimp ◑ = Hexagonal crimp

COPPER CONDUCTORS



DIE SELECTOR CHART

APPLICATION	CONDUCTOR	CONNECTOR		HYDRAULIC TOOLS								
				B15MD	HT45-E B450ND-BV				HT51 RH50 B500 B500ND			
				DIE SET	NEST	INDENTOR	DIE SET	NEST	INDENTOR	DIE SET		
COPPER CONDUCTORS  T-M.  L-T  T-L.	Conductor Size sqmm	TERMINAL	SPLICE									
	4 ÷ 6	T6-M.. T6-L..	L6-T..	MS4/10-15 	MA1 	PA1	MS6 	MA1-50 	PA1-50	MS6-50 		
	10	T10-M.. T10-L..	L10-T..	MS4/10-15 MS10/16-15 	MA2.3 	PA5	MS10 	MA2.3-50 	PA5-50	MS10-50 		
	16	T16-M.. T16-L..	L16-T..	MS10/16-15 			MS16 			MS16-50 		
	25	T25-M.. T25-L..	L25-T..		MA5 		MS25 	MA5-50 		MS25-50 		
	35	T35-M.. T35-L..	L35-T..		MA7 	PA10	MS35 	MA7-50 	PA10-50	MS35-50 		
	50	T50-M.. T50-L..	L50-T..		MA10 		MS50 	MA10-50 		MS50-50 		
	70	T70-M.. T70-L..	L70-T..				MS70 	MA14-50 	PA19-50	MS70-50 		
	95	T95-M.. T95-L..	L95-T..				MS95 	MA19-50 		MS95-50 		
	120	T120-M.. T120-L..	L120-T..				MS120 	MA24-50 	PA24-50	MS120-50 		
	150	T150-M.. T150-L..	L150-T..				MS150 			MS150-50 		
	185	T185-M..	L185-T..							MS185-50 		
	240	T240-M..	L240-T..							MS240-50 		
	300	T300-M..	L300-T..							MS300-50* 		
	400	T400-M..	L400-T..									

  = Indent crimp
  = Hexagonal crimp





















* Only for B500, B500ND and RH50

DIE SELECTOR CHART

HYDRAULIC TOOLS														
HT61 RH61 B600 [◇]			HT81-U RHU81			HT 120 and tools and heads with 130 kN crimping force			ECW-H3D			RHU520		
NEST	INDEN- TOR	DIE SET	NEST	DIE SET	NEST	INDEN- TOR	DIE SET	NEST	INDEN- TOR	DIE SET	NEST	INDEN- TOR	DIE SET	
MA1-50 ☺	PA1-50	MS6-50 ①		MS6-10-U ①			MS6-C ①							
MA2.3-50 ☺	PA5-50	MS10-50 ①	MA3.5-U ☺	MS6-10-U ①	MA2-C ☺	MS10-C ①	PA10-C	Adaptor AU230-130D with die set MA..-C and indentor PA..-C	Adaptor AU230-130D with die set MS..-C	Adaptor AU520-130C with die set MA..-C and indentor PA..-C	Adaptor AU520-130C with die set MS..-C			
		MS16-50 ①		MS16-25-U ①	MA3-C ☺	MS16-C ①								
MA5-50 ☺		MS25-50 ①		MS16-25-U ①	MA5-C ☺	MS25-C ①								
MA7-50 ☺	PA10-50	MS35-50 ②	MA7.14-U ☺	MS35-50-U ②	MA7-C ☺	MS35-C ①	PA24-C							
MA10-50 ☺		MS50-50 ②	MA10.19-U ☺	MS35-50-U ②	MA10-C ☺	MS50-C ①								
MA14-50 ☺	PA19-50	MS70-50 ②	MA9.17-U ☺	MS70-150-U ②	MA14-C ☺	MS70-C ①	PA48-C							
MA19-50 ☺		MS95-50 ②	MA10.19-U ☺	MS95-120-U ②	MA19-C ☺	MS95-C ①								
MA24-50 ☺	PA24-50	MS120-50 ②	MA24-U ☺	MS95-120-U ②	MA24-C ☺	MS120-C ①	PA60-C							
		MS150-50 ③	MA30.80-U ☺	MS70-150-U ③	MA30-C ☺	MS150-C ②								
		MS185-50 ③	MA35-U ☺	MS185-U ③	MA37-C ☺	MS185-C ②	MS300-C ③							
		MS240-50 ④	MA48-U ☺	MS240-U ④	MA48-C ☺	MS240-C ②								
					MA60-C ☺	MS400-C ③								

[◇] The tools type HT 61, RH 61 and B600 use the same dies as the HT51 with a spring type 6522051.

MUT DIES CROSS REFERENCE CHART

DIE INDEX	DIETYPE			
	 14.6 tons tools 131 series	 6 tons tools 51 series	 6 tons tools 45 series	 6 & 6.4 tons tools 54 & 55 series
161	MUT9999-C	MUT9999-50	MUT9999	MUT9999-W
162	MUT9998-C	MUT9998-50	MUT9998	MUT9998-W
163	MUT9997-C	MUT9997-50	MUT9997	MUT9997-W
164	MUT9996-C	MUT9996-50	MUT9996	MUT9996-W
166	MUT9995-C	MUT9995-50	MUT9995	MUT9995-W
167	MUT9958-C	-	-	MUT9958-W
168	MUT9974-C	-	-	-
169	MUT9979-C	-	-	-
170	MUT9973-C	-	-	-
203	MUT9943-C	MUT9943-50	-	MUT9943-W
204	MUT9941-C	MUT9941-50	-	MUT9941-W
209	MUT9972-C	-	-	-
239	MUT9993-C	MUT9993-50	MUT9993	MUT9993-W
242	MUT9967-C	-	-	-
243	MUT9991-C	MUT9991-50	MUT9991	MUT9991-W
247	-	MUT9954-50	-	MUT9954-W
249	MUT9990-C	MUT9990-50	MUT9990	MUT9990-W
253	MUT9957-C	-	-	-
255	MUT9962-C	-	-	-
261	MUT9956-C	-	-	-
296*	 beige	MUT9924-C	-	-
297*	 yellow olive	MUT9923-C	-	-
298*	 white	MUT9921-C	-	-
299*	 brown	MUT9918-C	-	-
300*	 pink	MUT9916-C	-	-
305	MUT9977-C	-	-	-
316	MUT9976-C	-	-	-
317	MUT9965-C	-	-	-
322	MUT9971-C	-	-	-
324*	 red	MUT9920-C	-	-
327	MUT9961-C	-	-	-
346*	 grey	MUT9928-C	-	-
348*	 pink	MUT9926-C	-	-
373	MUT9989-C	MUT9989-50	-	MUT9989-W
374*	 blue	MUT9929-C	-	-
375*	 green	MUT9927-C	-	-
467*	 rubin	MUT9922-C	-	-
470*	 blue	MUT9919-C	-	-
471*	 gold	MUT9925-C	-	-
472*	 green	MUT9917-C	-	-
473*	 black	MUT9915-C	-	-
490	MUT9966-C	-	-	-
642	MUT9970-C	-	-	-
654	MUT9975-C	MUT9975-50	-	-
655	MUT9968-C	-	-	-
658	MUT9988-C	MUT9988-50	-	MUT9988-W
659	MUT9987-C	MUT9987-50	MUT9987	MUT9987-W
936*	 yellow	MUT9914-C	-	-
698	MUT9986-C	MUT9986-50	MUT9986	MUT9986-W
699	MUT9985-C	MUT9985-50	-	MUT9985-W
708	MUT9959-C	-	-	-
756	MUT9964-C	-	-	-
788	MUT9950-C	-	-	-
790	MUT9969-C	-	-	-
BG	MUT9984-C	MUT9984-50	-	MUT9984-W
C	MUT9983-C	MUT9983-50	MUT9983	MUT9983-W
D	MUT9978-C	-	-	-
D3	MUT9981-C	MUT9981-50	-	-
E	MUT9982-C	MUT9982-50	-	MUT9982-W
F	MUT9960-C	-	-	-
K840	-	-	-	MUT9942-W
N	MUT9955-C	-	-	-
O	MUT9980-C	MUT9980-50	-	MUT9980-W

*Stainless steel dies

RHU600 DIES CROSS REFERENCE CHART

DIE INDEX	DIE TYPE			
	CEMBRE	ALCOA	HUSKIE	BURNDY
10SH	M10SH-600	6010SH	HA60-01	-
12SH	M12SH-600	6012SH	HA60-02	-
14SH	M14SH-600	6014SH	HA60-03	-
16SH	M16SH-600	6016SH	HA60-04	-
18SH	M18SH-600	6018SH	HA60-05	-
20SH	M20SH-600	6020SH	HA60-06	-
74SH	M74SH-600	6074SH	HA60-07	-
75SH	M75SH-600	6075SH	HA60-08	-
76SH	M76SH-600	6076SH	HA60-09	-
76.1SH	M76.1SH-600	6076.1SH	-	-
20AH	M20AH-600	6020AH	HA60-20	20AH60
24AH	M24AH-600	6024AH	HA60-21	24AH60
27AH	M27AH-600	6027AH	HA60-22	27AH60
30AH	M30AH-600	6030AH	HA60-23	30AH60
34AH	M34AH-600	6034AH	HA60-24	34AH60
36AH	M36AH-600	6036AH	HA60-25	36AH60
38AH	M38AH-600	6038AH	HA60-26	38AH60
40AH	M40AH-600	6040AH	HA60-27	40AH60
74AH	M74AH-600	6074AH	HA60-28	-
75AH	M75AH-600	6075AH	HA60-29	75AH60
76AH	M76AH-600	6076AH	HA60-30	76AH60
07CD	M7CD-600	6007CD	HA60-40	07CD60
08CD	M8CD-600	6008CD	HA60-41	08CD60
09CD	M9CD-600	6009CD	HA60-42	09CD60
10CD	M10CD-600	6010CD	HA60-43	10CD60
11CD	M11CD-600	6011CD	HA60-44	11CD60
12CD	M12CD-600	6012CD	HA60-45	12CD60
13CD	M13CD-600	6013CD	HA60-46	13CD60
14CD	M14CD-600	6014CD	HA60-47	14CD60
15CD	M15CD-600	6015CD	HA60-48	15CD60
16CD	M16CD-600	6016CD	HA60-49	16CD60
17CD	M17CD-600	6017CD	HA60-50	17CD60

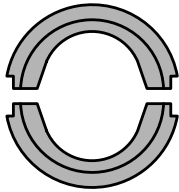
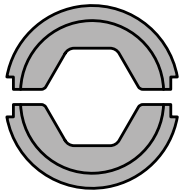

RHU1000 DIES CROSS REFERENCE CHART

DIE INDEX	DIETYPE		
	 CEMBRE	ALCOA	HUSKIE
10SH	M10SH-1000	10010SH	HA100-01
12SH	M12SH-1000	10012SH	HA100-02
14SH	M14SH-1000	10014SH	HA100-03
16SH	M16SH-1000	10016SH	HA100-04
18SH	M18SH-1000	10018SH	HA100-05
20SH	M20SH-1000	10020SH	HA100-06
76SH	M76SH-1000	10076SH	-
20AH	M20AH-1000	10020AH	HA100-20
24AH	M24AH-1000	10024AH	HA100-21
27AH	M27AH-1000	10027AH	HA100-22
30AH	M30AH-1000	10030AH	HA100-23
34AH	M34AH-1000	10034AH	HA100-24
36AH	M36AH-1000	10036AH	HA100-25
38AH	M38AH-1000	10038AH	HA100-26
40AH	M40AH-1000	10040AH	HA100-27
76AH	M76AH-1000	10076AH	HA100-30
42AH	M42AH-1000	10042AH	HA100-34
44AH	M44AH-1000	10044AH	HA100-36
48AH	M48AH-1000	10048AH	HA100-38
07CD	M7CD-1000	10007CD	HA100-40
08CD	M8CD-1000	10008CD	HA100-41
09CD	M9CD-1000	10009CD	HA100-42
10CD	M10CD-1000	10010CD	HA100-43
11CD	M11CD-1000	10011CD	HA100-44
12CD	M12CD-1000	10012CD	HA100-45
13CD	M13CD-1000	10013CD	HA100-46
14CD	M14CD-1000	10014CD	HA100-47
15CD	M15CD-1000	10015CD	HA100-48
16CD	M16CD-1000	10016CD	HA100-49
17CD	M17CD-1000	10017CD	HA100-50
18CD	M18CD-1000	10018CD	HA100-51
19CD	M19CD-1000	10019CD	HA100-52
20CD	M20CD-1000	10020CD	HA100-53



A P P E N D I X

Type/Code Cross-Reference chart

Type	Code	Type	Code	Type	Code	Type	Code	Type	Code
1052007	3005900	1143M40N	3005241	1702.2N	3004026	1890	3016410	1900DP.16	3001162
1052007N	3005901	1143M50	3005245	1702.5	3004425	1890A	3016420	1900DP.21	3001165
1052009	3005903	1143M50G	3005247	1702.5N	3004426	1891	3016430	1900DP.29	3001168
1052009N	3005904	1143M50N	3005246	1702CONC	3003523	1891A	3016431	1900DP.36	3001171
1052011	3005906	1143M63	3005250	1702CONCNC	3003524	1892	3016440	1900DP.42	3001174
1052011N	3005907	1143M63G	3005252	1702N	3003026	1892A	3016450	1900DP.48	3001177
1052013	3005909	1143M63N	3005251	1702P	3006025	1892B	3016451	1900DP.M12	3013380
1052013N	3005910	1150	3005745	1702PN	3006026	1893	3016460	1900DP.M16	3013383
1052016	3005912	1150N	3005746	1702T	3003519	1893A	3016461	1900DP.M20	3013386
1052016N	3005913	1163	3005750	1702TN	3003520	1894	3016480	1900DP.M25	3013389
1052021	3005915	1163N	3005751	1703	3003030	1895	3016490	1900DP.M32	3013392
1052021N	3005916	1253M12	3006750	1703.2	3004030	1896	3016500	1900DP.M40	3013395
1052029	3005918	1253M12N	3006751	1703.5	3004430	1897	3016510	1900DP.M50	3013398
1052029N	3005919	1253M16	3006755	1703P	3006030	1898	3016520	1900DP.M63	3013401
1052036	3005921	1253M16N	3006756	1704	3003035	1899	3016530	1901.07	3001503
1052036N	3005922	1253M20	3006760	1704.2	3004035	1899A	3016535	1901.07N	3001504
1052042	3005924	1253M20N	3006761	1704P	3006035	1899B	3016540	1901.09	3001515
1052042N	3005925	1253M25	3006765	1705	3003040	1900.07	3001010	1901.09N	3001516
1052048	3005927	1253M25N	3006766	1705.2	3004040	1900.07G	3001012	1901.11	3001520
1052048N	3005928	1253M32	3006770	1706	3003045	1900.07N	3001011	1901.11N	3001521
1053M12	3005958	1253M32N	3006771	1707	3003050	1900.07/X	3001077	1901.13	3001535
1053M12N	3005959	1253M40	3006775	1708	3003055	1900.09	3001015	1901.13N	3001536
1053M16	3005961	1253M40N	3006776	1709	3003010	1900.09G	3001017	1901.16	3001550
1053M16N	3005962	1253M50	3006780	1710	3005515	1900.09N	3001016	1901.16N	3001551
1053M20	3005964	1253M50N	3006781	1710N	3005516	1900.09/X	3001080	1901.21	3001568
1053M20N	3005965	1253M63	3006785	1711	3005520	1900.11	3001020	1901.21N	3001569
1053M25	3005967	1253M63N	3006786	1711N	3005521	1900.11G	3001022	1901.29	3001575
1053M25N	3005968	1400	3003110	1712	3005525	1900.11N	3001021	1901.29N	3001576
1053M32	3005970	1401	3003114	1712N	3005526	1900.11/X	3001083	1901.36	3001582
1053M32N	3005971	1401B	3003116	1713	3005530	1900.12	3001120	1901.36N	3001583
1053M40	3005973	1401BN	3003117	1713N	3005531	1900.12N	3001121	1901.42	3001590
1053M40N	3005974	1401N	3003115	1714	3005535	1900.13	3001025	1901.42N	3001591
1053M50	3005976	1402	3003120	1,71E+37	3005572	1900.13G	3001027	1901.48	3001596
1053M50N	3005977	1402N	3003121	1714N	3005536	1900.13N	3001026	1901.48N	3001597
1053M63	3005979	1403	3003125	1715	3005540	1900.13/X	3001086	1901.M12	3001650
1053M63N	3005980	1404	3003130	1715N	3005541	1900.14	3001110	1901.M12G	3001652
1112	3005715	1405	3003135	1719	3005510	1900.14N	3001111	1901.M12N	3001651
1112N	3005716	1407	3003155	1,72E+20	3005581	1900.16	3001030	1901.M16	3001655
1116	3005720	1408	3003170	1719E17N	3005580	1900.16G	3001032	1901.M16G	3001657
1116N	3005721	1410	3005610	1719N	3005511	1900.16N	3001031	1901.M16N	3001656
1120	3005725	1410N	3005611	1730M20	3003225	1900.16/X	3001089	1901.M20	3001660
1120N	3005726	1411	3005615	1730M20N	3003226	1900.21	3001035	1901.M20G	3001662
1125	3005730	1411N	3005616	180709	3017610	1900.21G	3001037	1901.M20N	3001661
1125N	3005731	1412	3005620	180911	3017620	1900.21N	3001036	1901.M25	3001665
1132	3005735	1412N	3005621	180913	3017625	1900.21/X	3001092	1901.M25G	3001667
1132N	3005736	1414	3005630	181113	3017630	1900.29	3001040	1901.M25N	3001666
1140	3005740	1414N	3005631	181116	3017640	1900.29G	3001042	1901.M32	3001670
1140N	3005741	1415	3005635	181316	3017650	1900.29N	3001041	1901.M32G	3001672
1141012	3005120	1415N	3005636	181321	3017655	1900.29/X	3001095	1901.M32N	3001671
1141012N	3005121	1500.07	3002010	181621	3017660	1900.34	3001130	1901.M40	3001675
1141112	3005155	1500.07N	3002011	182129	3017670	1900.34N	3001131	1901.M40G	3001677
1141112N	3005156	1500.09	3002015	182936	3017680	1900.36	3001045	1901.M40N	3001676
1141200	3005170	1500.09N	3002016	1830	3004110	1900.36G	3001047	1901.M50	3001680
1141200N	3005171	1500.11	3002020	1830N	3004111	1900.36N	3001046	1901.M50G	3001682
1142007	3005010	1500.11N	3002021	1831	3004115	1900.36/X	3001098	1901.M50N	3001681
1142007G	3005012	1500.12	3002120	1831N	3004116	1900.38	3001115	1901.M63	3001685
1142007N	3005011	1500.12N	3002121	1832	3004120	1900.38N	3001116	1901.M63G	3001687
1142009	3005015	1500.13	3002025	1832N	3004121	1900.42	3001050	1901.M63N	3001686
1142009G	3005017	1500.13N	3002026	1835G	3004222	1900.42G	3001052	1902.13N	3001538
1142009N	3005016	1500.14	3002110	1836	3004225	1900.42N	3001051	1910.07	3001501
1142011	3005020	1500.14N	3002111	183642	3017690	1900.42/X	3001101	1910.07N	3001502
1142011G	3005022	1500.16	3002030	1836N	3004226	1900.48	3001055	1910.09	3001509
1142011N	3005021	1500.16N	3002031	1840	3006610	1900.48G	3001057	1910.09N	3001510
1142013	3005025	1500.21	3002035	1840N	3006611	1900.48N	3001056	1910.11	3001526
1142013G	3005027	1500.21N	3002036	1841	3006615	1900.48/X	3001104	1910.11N	3001527
1142013N	3005026	1500.34	3002130	1841N	3006616	1900.M12	3001215	1910.13	3001539
1142016	3005030	1500.34N	3002131	1842	3006620	1900.M12G	3001217	1910.13N	3001540
1142016G	3005032	1500.38	3002115	184248	3017700	1900.M12N	3001216	1910.16	3001552
1142016N	3005031	1500.38N	3002116	1842N	3006621	1900.M12/X	3001310	1910.16N	3001553
1142021	3005035	1500.M12	3002205	1843	3006625	1900.M16	3001220	1910.21	3001565
1142021G	3005037	1500.M12N	3002206	1843N	3006626	1900.M16G	3001222	1910.21N	3001566
1142021N	3005036	1500.M16	3002210	1844	3006630	1900.M16N	3001221	1910.29	3001578
1142029	3005040	1500.M16N	3002211	1844N	3006631	1900.M16/X	3001313	1910.29N	3001579
1142029G	3005042	1500.M20	3002215	1845	3006635	1900.M20	3001225	1910.36	3001588
1142029N	3005041	1500.M20N	3002216	1845N	3006636	1900.M20G	3001227	1910.36N	3001589
1142036	3005045	1500.M25	3002220	1846	3006640	1900.M20N	3001226	1910.42	3001592
1142036G	3005047	1500.M25N	3002221	1846N	3006641	1900.M20/X	3001316	1910.42N	3001593
1142036N	3005046	1500.M32	3002225	1847	3006645	1900.M25	3001230	1910.48	3001598
1142042	3005050	1500.M32N	3002226	1847N	3006646	1900.M25G	3001232	1910.48N	3001599
1142042G	3005052	1618.90	3041350	1848	3006650	1900.M25N	3001231	1910.M12	3001705
1142042N	3005051	1626.90	3041360	1848N	3006651	1900.M25/X	3001319	1910.M12G	3001707
1142048	3005055	1636.90	3041370	1849	3006655	1900.M32	3001235	1910.M12N	3001706
1142048G	3005057	1651.90	3041380	1849N	3006656	1900.M32G	3001237	1910.M16	3001710
1142048N	3005056	1676.90	3041390	1861	3004515	1900.M32N	3001236	1910.M16G	3001712
1143M12	3005215	1700	3003015	1861N	3004516	1900.M32/X	3001322	1910.M16N	3001711
1143M12G	3005217	1700.2	3004015	1862	3004520	1900.M40	3001240	1910.M20	3001715
1143M12N	3005216	1700.2N	3004016	1862N	3004521	1900.M40G	3001242	1910.M20G	3001717
1143M16	3005220	1700N	3003016	1866	3004615	1900.M40N	3001241	1910.M20N	3001716
1143M16G	3005222	1700P	3006015	1866N	3004616	1900.M40/X	3001325	1910.M25	3001720
1143M16N	3005221	1700T	3003515	1880	3016215	1900.M50	3001245	1910.M25G	3001722
1143M20	3005225	1700TN	3003516	1881	3016220	1900.M50G	3001247	1910.M25N	3001721
1143M20G	3005227	1701	3003020	1882	3016225	1900.M50N	3001246	1910.M32	3001725
1143M20N	3005226	1701.2	3004020	1883	3016230	1900.M50/X	3001328	1910.M32G	3001727
1143M25	3005230	1701.2N	3004021	1884	3016235	1900.M63	3001250	1910.M32N	3001726
1143M25G	3005232	1701N	3003021	1884A	3016236	1900.M63G	3001252	1910.M40	3001730
1143M25N	3005231	1701P	3006020	1885	3016240	1900.M63N	3001251	1910.M40G	3001732
1143M32	3005235	1701PN	3006021	1886	3016245	1900.M63/X	3001331	1910.M40N	3001731
1143M32G	3005237	1701T	3003517	1887	3016250	1900DP.07	3001150	1910.M50	3001735
1143M32N	3005236	1701TN	3003518	1888	3016255	1900DP.09	3001153	1910.M50G	3001737
1143M40	300524								

Type/Code Cross-Reference chart

Type	Code	Type	Code	Type	Code	Type	Code	Type	Code
1910.M63G	3001742	20424836N	3017890	2900.21N	3012035	2A24-M12	2505150	36A3M20356	3016923
1910.M63N	3001741	20424842N	3017895	2900.29N	3012040	2A24-M14	2505230	36A3M2526	3016930
1925.3	3016470	20431612N	3017949	2900.36N	3012045	2A24-M16	2505310	36A3M2536	3016932
200101241N	3013121	20432012N	3017951	2900.42N	3012050	2A24-M20	2505390	36A3M2537	3016934
200101441N	3013111	20432016N	3017953	2900.48N	3012055	2A3-M10	2500070	36A3M2545	3016936
200103441N	3013131	20432512N	3017955	2900.M12N	3012215	2A3-M8	2500030	36A3M2546	3016937
200103841N	3013116	20432516N	3017957	2900.M16N	3012220	2A30-M10	2506020	36A3M2554	3016938
200105841N	3013126	20432520N	3017959	2900.M20N	3012225	2A30-M12	2506030	36A3M3228	3016944
200110041N	3013136	20433220N	3017961	2900.M25N	3012230	2A30-M14	2506110	36A3M3239	3016946
200111241N	3013156	20433225N	3017963	2900.M32N	3012235	2A30-M16	2506190	36A3M32465	3016945
200111441N	3013146	20434025N	3017965	2900.M40N	3012240	2A30-M20	2506270	36A3M3248	3016943
200111841N	3013141	20434032N	3017967	2900.M50N	3012245	2A37-M12	2507070	36A3M4078	3016952
200120041N	3013171	20435032N	3017969	2900.M63N	3012250	2A37-M14	2507110	36A3M40106	3016954
200121221N	3013186	20435040N	3017971	2900DP.07N	3012160	2A37-M16	2507190	36A3M5088	3016968
200130021N	3013196	20436340N	3017973	2900DP.09N	3012162	2A37-M20	2507270	36C201629	3016982
200200721N	3013011	20436350N	3017975	2900DP.11N	3012164	2A48-M12	2508030	36C3M252105	3016985
200200921N	3013016	2052007N	3011810	2900DP.13N	3012166	2A48-M14	2508070	4300-3127	2590942
200201121N	3013021	2052009N	3011815	2900DP.16N	3012168	2A48-M16	2508110	4300-3128	2590930
200201321N	3013026	2052011N	3011820	2900DP.21N	3012170	2A48-M20	2508190	4300-3129	2590931
200201621N	3013031	2052013N	3011825	2900DP.29N	3012172	2A5-M10	2500570	4300-3132	2590957
200202121N	3013036	2052016N	3011830	2900DP.36N	3012174	2A5-M12	2500650	4300-3136	2590950
200202921N	3013041	2052021N	3011835	2900DP.42N	3012176	2A5-M8	2500530	4300-3137	2590934
200203621N	3013046	2052029N	3011840	2900DP.48N	3012178	2A60-M12	2508480	4300-3138	2590954
200204221N	3013051	2052036N	3011845	2900DP.M12N	3012315	2A60-M14	2508500	4300-3140	2590951
200204821N	3013056	2052042N	3011850	2900DP.M16N	3012317	2A60-M16	2508530	4300-3144	2590958
2003M1221N	3013215	2052048N	3011855	2900DP.M20N	3012319	2A60-M20	2508610	4300-3146	2590947
2003M1621N	3013220	2053M12N	3011910	2900DP.M25N	3012321	2A7-M10	2501110	4300-3147	2590938
2003M2021N	3013225	2053M16N	3011915	2900DP.M32N	3012323	2A7-M12	2501150	4300-3148	2590939
2003M2521N	3013230	2053M20N	3011920	2900DP.M40N	3012325	2A7-M8	2501030	4300-3153	2590943
2003M3221N	3013235	2053M25N	3011925	2900DP.M50N	3012327	2A80-M12	2509030	4300-3154	2590944
2003M4021N	3013240	2053M32N	3011930	2900DP.M63N	3012329	2A80-M14	2509070	4300-3241	2590935
2003M5021N	3013245	2053M40N	3011935	2901.07N	3012590	2A80-M16	2509150	4300-3258	2590932
2003M6321N	3013250	2053M50N	3011940	2901.09N	3012593	2A80-M20	2509230	4300-3262	2590933
2021012	3014120	2053M63N	3011945	2901.11N	3012596	2A10-2M12	2502410	4300-3539	2590959
2021012N	3014121	207101441N	3013608	2901.13N	3012599	2A14-2M12	2503310	4300-3540	2590960
2021014	3014110	20931216N	3017705	2901.16N	3012602	2A14-2M14	2503315	4300-3541	2590961
2021014N	3014111	20931620N	3017707	2901.21N	3012605	2A19-2M12	2504480	4320-0864	2591274
2021034	3014130	20932025N	3017709	2901.29N	3012608	2A19-2M14	2504510	4320-0865	2591272
2021034N	3014131	20932532N	3017711	2901.36N	3012611	2A24-2M12	2505490	4320-0866	2591273
2021038	3014115	20932540N	3017713	2901.42N	3012614	2A24-2M14	2505560	4900.07	3002710
2021038N	3014116	20933240N	3017715	2901.M12N	3012650	2A24-2M16	2505590	4900.09	3002713
2021058	3014125	20933250N	3017717	2901.M16N	3012652	2A30-2M12	2506400	4900.11	3002716
2021058N	3014126	20934050N	3017719	2901.M20N	3012654	2A30-2M14	2506410	4900.13	3002719
2021100	3014135	20935063N	3017721	2901.M25N	3012656	2A37-2M12	2507420	4900.16	3002722
2021100N	3014136	20A40916N	3018650	2901.M32N	3012658	2A37-2M14	2507440	4900.21	3002725
2021112	3014155	20A41120N	3018655	2901.M40N	3012660	2A37-2M16	2507490	4900.29	3002728
2021112N	3014156	20A41320N	3018657	2901.M50N	3012662	2A48-2M12	2508380	4900.36	3002731
2021114	3014145	20A41620N	3018659	2910.07N	3012501	2A48-2M14	2508410	4900.42	3002734
2021114N	3014146	20A42011N	3018610	2910.09N	3012511	2A48-2M16	2508430	4900.48	3002737
2021118	3014140	20A42016N	3018612	2910.11N	3012521	2A60-2M12	2508700	4900.M12	3002750
2021118N	3014141	20A42120N	3018661	2910.13N	3012531	2A60-2M14	2508760	4900.M16	3002753
2021200	3014170	20A42125N	3018665	2910.16N	3012541	2A60-2M16	2508770	4900.M20	3002756
2021200N	3014171	20A42513N	3018615	2910.21N	3012551	2A80-2M12	2509310	4900.M25	3002759
2031012N	3015621	20A42516N	3018617	2910.29N	3012555	2A80-2M14	2509350	4900.M32	3002762
2031014N	3015611	20A42925N	3018667	2910.36N	3012560	2A80-2M14/55°	2509346	4900.M40	3002765
2031034N	3015631	20A43216N	3018620	2910.42N	3012565	2A80-2M16	2509390	4900.M50	3002768
2031038N	3015616	20A43221N	3018621	2910.48N	3012570	2A100-2M12	2509742	4900.M63	3002771
2031058N	3015626	20M3M1261N	3011410	2910.M12N	3012710	2A100-2M14	2509760	4901.07	3002910
2031100N	3015636	20M3M1661N	3011412	2910.M16N	3012712	2A100-2M16	2509780	4901.09	3002913
2031112N	3015656	20M3M2061N	3011414	2910.M20N	3012714	2A120-2M12	2509910	4901.11	3002916
2031114N	3015646	20M3M2561N	3011416	2910.M25N	3012716	2A120-2M14	2509930	4901.13	3002919
2031118N	3015641	20M3M3261N	3011418	2910.M32N	3012718	2A120-2M14/55°	2509952	4901.16	3002922
2031200N	3015671	20M3M4061N	3011420	2910.M40N	3012720	2A120-2M16	2509970	4901.21	3002925
2031212N	3015686	20M3M5061N	3011422	2910.M50N	3012722	2A160-2M14	8008603	4901.29	3002928
2031300N	3015696	20M3M6361N	3011424	2910.M63N	3012724	2A160-2M16	2509982	4901.36	3002931
2032007N	3015511	20N3M12N	3015810	2911.07N	3012110	2A200-2M12	2509993	4901.42	3002934
2032009N	3015516	20N3M16N	3015812	2911.09N	3012113	2A200-2M16	2509985	4901.48	3002937
2032011N	3015521	20N3M20N	3015814	2911.11N	3012116	2A200-2M20	2509994	4901.M12	3002950
2032013N	3015526	20N3M25N	3015816	2911.13N	3012119	3411012	3016645	4901.M16	3002953
2032016N	3015531	20N3M32N	3015818	2911.16N	3012122	3411014	3016615	4901.M20	3002956
2032021N	3015536	20N3M40N	3015820	2911.21N	3012125	3411034	3016665	4901.M25	3002959
2032029N	3015541	20N3M50N	3015822	2911.29N	3012128	3411038	3016625	4901.M32	3002962
2032036N	3015546	20N3M63N	3015824	2911.36N	3012131	3411100	3016695	4901.M40	3002965
2032042N	3015551	2155	3051010	2911.42N	3012134	3412011	3016635	4901.M50	3002968
2032048N	3015556	2156	3051015	2911.M12N	3012750	3412016	3016657	4901.M63	3002971
2033M12N	3015751	2157	3051020	2911.M16N	3012752	3412021	3016685	5116660210	3061210
2033M16N	3015756	2158	3051125	2911.M20N	3012754	3412029	3016705	5116660500	3061215
2033M20N	3015761	2160	3051130	2911.M25N	3012756	3422016	3016658	5313202048	3061605
2033M25N	3015766	2161	3051135	2911.M32N	3012758	3431100	3016895	5523036090	3061610
2033M32N	3015771	2162	3051140	2911.M40N	3012760	3441012	3017045	5527030079	3061615
2033M40N	3015776	2163	3051145	2911.M50N	3012762	3441034	3017065	5900.M12N	3012810
2033M50N	3015781	2164	3051150	2A10-M10	2502070	3572007	3017410	5900.M16N	3012812
20420907N	3017810	2171	3051310	2A10-M12	2502150	3572011	3017430	5900.M20N	3012814
20421107N	3017820	2172	3051315	2A10-M14	2502190	3572013	3017445	5900.M25N	3012816
20421109N	3017822	2173	3051320	2A10-M16	2502230	35720131	3017446	5900.M32N	3012818
20421307N	3017830	2174	3051325	2A100-M16	2509630	3572016	3017455	5900.M40N	3012820
20421309N	3017832	2176	3051430	2A100-M20	2509670	3572021	3017480	5900.M50N	3012822
20421311N	3017835	2323	3052010	2A120-M16	2509870	3573M16	3017520	5900.M63N	3012824
20421607N	3017840	2326	3052020	2A120-M20	2509890	3573M20	3017530	5901.M12N	3012850
20421609N	3017842	2329	3052030	2A14-M10	2503030	3573M25	3017540	5901.M16N	3012852
20421611N	3017845	2333	3052110	2A14-M12	2503110	3573M32	3017550	5901.M20N	3012854
20421613N	3017847	2336	3052120	2A14-M14	2503150	3601	3026020	5901.M25N	3012856
20422111N	3017850	2339	3052130	2A14-M16	2503190	3602	3026030	5901.M32N	3012858
20422113N	3017855	2342	3052140	2A160-M20	2509980	3603	3026040		

Type/Code Cross-Reference chart

Type	Code	Type	Code	Type	Code	Type	Code	Type	Code
6010.34	3016060	A19-L8	2260560	A30-M10	2300110	A10-2M8-24-24	2221467	AA300-34-M16	2743215
6010.36	3016110	A19-L10	2260570	A30-M12	2300150	A10-2M10-24-13	2221493	AA400-M16	2743310
6010.38	3016020	A19-L12	2260610	A30-M14	2300230	A10-2M12	2221480	AA50-M12	2740110
6010.42	3016120	A24-L10	2281010	A30-M16	2300270	A10-2M12-25	2221470	AA50-M14	2740150
6010.48	3016130	A24-L12	2281050	A30-M20	2300350	A14-2M8-24-24	2241552	AA500-40-M16	2743330
6010.58	3016050	A30-L10	2300870	A30-M8	2300070	A14-2M10-24	2241565	AA630-M16	2743370
6.010.114	3016070	A30-L12	2300910	A30B-M10/19	2300120	A14-2M12-25	2241590	AA70-M12	2740510
7032007	3010604	A37-L10	2320510	A30B-M8/19	2300080	A14-2M12-30-29	2241592	AA70-M14	2740550
7032009	3010606	A37-L12	2320550	A35-M10	2310265	A14-2M12-40	2241600	AA95-M12	2741030
7032011	3010608	A48-L10	2341293	A35-M12	2310270	A19-2M6	2261220	AA95-M14	2741070
7032013	3010610	A48-L12	2341295	A35-M14	2310310	A19-2M8-50 S	2261334	AB13	3041530
7032016	3010614	A60-L12	2351010	A35-M16	2310350	A19-2M10-24-13	2261348	AB13N	3041531
7032021	3010616	A03-M3	2100030	A35-M20	2310390	A19-2M10-24-26	2261350	AB19	3041532
7032029	3010618	A03-M3.5	2100070	A37-M10	2320110	A19-2M10-40	2261360	AB19N	3041533
7032036	3010620	A03-M4	2100110	A37-M12	2320150	A19-2M12-25	2261370	AB28	3041534
7032042	3010622	A03-M5	2100150	A37-M14	2320190	A19-2M12-30-29	2261379	AB28N	3041535
7032048	3010624	A03-M6	2100190	A37-M16	2320230	A19-2M14-25	2261400	AC130-P	2615531
7032A007	3010628	A06-M3	2101030	A37-M20	2320270	A24-2M8-20	2281780	ANE10-M6	2439350
7032A009	3010630	A06-M3.5	2101070	A37-M8	2320070	A24-2M8-24-29	2281790	ANE10-M8	2439360
7032A011	3010632	A06-M4	2101110	A37B-M10/24.5	2320120	A24B-2M8-25/19	2281777	ANE10-M10	2439370
7032A013	3010634	A06-M5	2101150	A3-M10	2180270	A24B-2M8-45/19	2281779	ANE10-M12	2439380
7032A016	3010636	A06-M6	2101190	A3-M12	2180310	A24-2M10	2281810	ANE12-M10	2442220
7032A021	3010638	A06-M8	2101230	A3-M4	2180030	A24-2M10-22	2281815	ANE12-M10/19	2442225
7032A029	3010640	A10-M10	2220150	A3-M5	2180110	A24-2M10-25/24	2281817	ANE12-M12	2442230
7032A036	3010642	A10-M12	2220190	A3-M5/9	2180120	A24-2M10-33.5	2281825	ANE12-M6/15	2442200
7032A042	3010644	A10-M14	2220230	A3-M6	2180150	A24L-2M10-30AS	2281840	ANE12-M8	2442210
7032A048	3010646	A10-M16	2220270	A3-M8	2180190	A24-2M12-30-29	2281910	ANE14-M6	2446410
7033M12	3010652	A10-M6	2220070	A3-P14	2180830	A24-2M12-40	2281920	ANE14-M8	2446420
7033M16	3010654	A10-M8	2220110	A40-M10	2330230	A24-2M14	2282210	ANE14-M10	2446430
7033M20	3010656	A10-P25	2221990	A40-M12	2330270	A24-2M16	2282213	ANE14-M12	2446440
7033M25	3010658	A100-M16	2370030	A40-M14	2330310	A30-2M8-20	2301250	ANE14-M14	2446450
7033M32	3010660	A100-M20	2370110	A40-M16	2330350	A30-2M10-24-28	2301260	ANE17-M10	2447260
7033M40	3010662	A10B-M6/11.5	2220078	A40-M20	2330390	A30-2M12-30	2301350	ANE17-M10/19	2447265
7033M50	3010664	A12-M10	2230270	A48-M10	2340110	A30-2M12-30-29	2301359	ANE17-M12	2447270
7033M63	3010666	A12-M10/19	2230280	A48-M10/31	2340120	A30-2M12-40	2301367	ANE17-M14	2447280
7033AM12	3010670	A12-M12	2230310	A48-M12	2340150	A30-2M14	2301650	ANE17-M16	2447290
7033AM16	3010672	A12-M6/15	2230210	A48-M12/31	2340158	A30-2M14-33.5	2301653	ANE17-M6	2447240
7033AM20	3010674	A12-M8	2230230	A48-M14	2340190	A37-2M10-25	2320890	ANE17-M8	2447250
7033AM25	3010676	A120-M16	2372070	A48-M16	2340230	A37-2M12	2320910	ANE19-M8	2449510
7033AM32	3010678	A120-M20	2372150	A48-M16/31	2340238	A37-2M12-32	2320915	ANE19-M10	2449520
7033AM40	3010680	A14-M10	2240230	A48-M20	2340310	A37-2M12-30-31	2320919	ANE19-M12	2449530
7033AM50	3010682	A14-M12	2240270	A48-M8	2340070	A37-2M14	2320970	ANE19-M14	2449540
7033AM63	3010684	A14-M14	2240310	A5-M10	2190190	A37-2M14-35	2320950	ANE19-M16	2449550
7900.07	3010000	A14-M16	2240350	A5-M12	2190230	A37-2M16-40	2320990	ANE2-M10	2408840
7900.09	3010005	A14-M6	2240110	A5-M4	2190030	A48-2M10-20	2340730	ANE2-M12	2408845
7900.11	3010010	A14-M8	2240150	A5-M5	2190070	A48-2M10-35	2340740	ANE2-M4	2408820
7900.13	3010015	A14-P30	2241730	A5-M5/9	2190075	A48-2M12	2340820	ANE2-M5	2408825
7900.16	3010020	A14B-M6/11.5	2240118	A5-M6	2190110	A48-2M12-35	2340790	ANE2-M6	2408830
7900.21	3010025	A160-M16	2374150	A5-M8	2190150	A48-2M12-40	2340810	ANE2-M8	2408835
7900.29	3010030	A160-M20	2374170	A5-P16	2191510	A48-2M12-30-31	2340770	ANE2-P12	2408850
7900.36	3010035	A17-M10	2250270	A60-M10	2350030	A48-2M14	2340860	ANE2-U4	2408860
7900.42	3010040	A17-M10/19	2250280	A60-M12	2350070	A48-2M14-40	2340850	ANE2-U5	2408865
7900.48	3010045	A17-M12	2250310	A60-M14	2350150	A60-2M12	2350600	ANE2-M10	2451320
7900A.07	3010060	A17-M14	2250350	A60-M16	2350190	A60-2M12-40	2350610	ANE20-M12	2451330
7900A.09	3010062	A17-M16	2250860	A60-M20	2350230	A60-2M12-30-38	2350620	ANE20-M14	2451340
7900A.11	3010064	A17-M6	2250210	A60B-M10/31	2350033	A60-2M14	2350660	ANE20-M16	2451350
7900A.13	3010066	A17-M8	2250230	A60B-M12/31	2350072	A60-2M16-40	2350730	ANE20-M8	2451310
7900A.16	3010068	A19-M10	2260190	A7-M10	2200190	A60-2M16	2350740	ANE24-M10	2453530
7900A.21	3010070	A19-M12	2260230	A7-M12	2200230	A60-2M16-35	2350750	ANE24-M12	2453550
7900A.29	3010072	A19-M14	2260270	A7-M5	2200070	A80-2M14	2360510	ANE24-M14	2453570
7900A.36	3010074	A19-M16	2260310	A7-M6	2200110	A80-2M14-40	2360500	ANE24-M16	2453590
7900A.42	3010076	A19-M20	2260390	A7-M8	2200150	A80-2M16-40	2360600	ANE29-M10	2456010
7900A.48	3010078	A19-M6	2260110	A7-P20	2201750	A80B-2M16-40	2360601	ANE29-M12	2456030
7900.M12	3010110	A19-M8	2260150	A7B-M6/11.5	2200120	A80-2M16-50	2360610	ANE29-M14	2456050
7900.M16	3010113	A19B-M8/15.5	2260163	A80-M12	2360030	A5-2M8-24-24/345	2190461	ANE29-M16	2456070
7900.M20	3010116	A1-M10	2103270	A80-M14	2360070	A5-2M12-30-29/345	2190480	ANE29-M20	2456090
7900.M25	3010119	A1-M3	2103030	A80-M16	2360110	A10-2M8-24-24/345	2221466	ANE3-M10	2415840
7900.M32	3010122	A1-M3.5	2103070	A80-M20	2360150	A14-2M8-24-24/345	2241550	ANE3-M12	2415850
7900.M40	3010125	A1-M4	2103110	A9-M10	2210270	A14-2M10-24-26/315	2241570	ANE3-M4	2415800
7900.M50	3010128	A1-M5	2103150	A9-M12	2210310	A14-2M10-24-26/345	2241572	ANE3-M5	2415810
7900.M63	3010131	A1-M6	2103190	A9-M6/15	2210210	A14-2M12-30-29/345	2241593	ANE3-M6	2415820
7900A.M12	3010150	A1-M8	2103230	A9-M8	2210230	A19-2M8-24-24/345	2261330	ANE3-M8	2415830
7900A.M16	3010152	A20-M10	2270270	A3-P22R	2180840	A19-2M10-24-26/345	2261351	ANE3-P14	2415860
7900A.M20	3010154	A20-M12	2270310	A3-P22R/45	2180843	A19-2M12-30-29/345	2261380	ANE3-U4	2415870
7900A.M25	3010156	A20-M14	2270350	A5-P22R	2191515	A24-2M8-24-29/345	2281791	ANE3-U5	2415875
7900A.M32	3010158	A20-M16	2270390	A5-P22R/45	2191518	A24-2M10-24-29/345	2281827	ANE30-M12	2458320
7900A.M40	3010160	A20-M8	2270230	A2-U4	2170510	A24-2M12-30-29/345	2281911	ANE30-M14	2458350
7900A.M50	3010162	A200-M16	2376090	A2-U5	2170520	A30-2M8-24-29/345	2301255	ANE30-M16	2458370
7900A.M63	3010164	A200-M20	2376100	A3-U4	2181990	A30-2M10-24-28/345	2301262	ANE30-M20	2458390
A1-L6	2103200	A24-M10	2280150	A3-U5	2182000	A30-2M12-30-29/345	2301360	ANE35-M12	2460010
A2-L5	2170820	A24-M12	2280190	A100-4ESI	2370990	A37-2M10-25/315	2320891	ANE35-M14	2460030
A2-L6	2170830	A24-M14	2280230	A120-4ESI	2372850	A37-2M12-30-31/345	2320920	ANE35-M16	2460050
A2-L8	2170850	A24-M16	2280270	A160-4ESI	2374350	A48-2M12/345	2340775	ANE35-M20	2460070
A3-L5	2180620	A24-M20	2280310	A37-4ESI	2321510	A48-2M12-30/45	2340765	ANE5-M10	2418540
A3-L6	2180630	A24-M8	2280110	A48-4ESI	2340950	A48-2M12-30-31/345	2340771	ANE5-M12	2418550
A3-L8	2180640	A24B-M10/19	2280155	A60-4ESI	2350850	A60-2M12-30-38/345	2350621	ANE5-M4	2418500
A3-L10	2180659	A24B-M8/19	2280115	A80-4ESI	2360850	AA16-M8	2740020	ANE5-M5	2418510
A5-L6	2190670	A29-M10	2290270	A2-2M4-12	2170750	AA25-M8	2740050	ANE5-M6	2418520
A5-L8	2190710	A29-M12	2290310	A2-2M8-20	2170770	AA35-M8	2740070	ANE5-M8	2418530
A5-L10	2190750	A29-M14	2290350	A3-2M8-20	2181750	AA35-M10	2740075	ANE5-P16	2418560
A7-L6	2200710	A29-M16	2290390	A3-2M12-40	2181751	AA120-M12	2741510	ANE7-M6	2422300
A7-L8	2200750	A29-M20	2290430	A5-2M8-20	2190450	AA120-M14	2741550	ANE7-M8	2422310
A7-L10	2200790	A29-M8	2290230	A5-2M8-24-24	2190460	AA150-M12	2742030	ANE7-M10	2422320
A7-L12	2200830	A2-M10	2170270	A5-2M10-24-13	2190470	AA150-M14	2742070	ANE7-M12	2422330
A10-L6	2220605	A2-M12	2170310	A7-2M10-25	2201190	AA185-M12	2742510	ANE7-P20	2422360
A10-L8	2220610	A2-M4	2170070	A7-2M12-25	2200990	AA185-M14	2742550	ANE9-M10	2430170
A10-L10	2220650	A2-M5	2170150	A7-2M12-40	2200995	AA240-M12	2743030	ANE9-M12	2430180
A10-L12	2220690	A2-M5/9	2170155	A10-2M6	2221463	AA240-M14	2743070	ANE9-M6/15	2430150
A14-L8	2241245	A2-M6	2170190	A10-2M8-20	2221465	AA300-M16	2743150	ANE9-M8	2430160
A14-L10									

Type/Code Cross-Reference chart

Type	Code	Type	Code	Type	Code	Type	Code	Type	Code
AU130-150	2615560	BKF-F405P	2053567	B5CL2/0	2489545	C6-12	2395320	CAA240-M12	2760590
AU130-240	2615590	BKF-F408	2053572	B5CL250	2489560	C6-14	2395260	CAA25-M12	2760030
AU230-130D	2636960	BKF-F408P	2053577	B5CL3	2489525	C6-38	2395300	CAA300-M16	2760710
AU230-630	2680300	BKF-F608	2053612	B5CL3/0	2489550	C6-516	2395280	CAA300-34-M12	2760680
AU520-130C	2648230	BKF-F608P	2053622	B5CL300	2489565	C6-8	2395220	CAA300-34-M16	2760715
AU55-50	2672515	BKF-FM608	2053692	B5CL350	2489570	C750-12	2398320	CAA35-M12	2760070
AU55-W	2672511	BKF-M608	2053652	B5CL4	2489520	C750-34	2398380	CAA35ADN	2762260
B-FC470	2598880	BKY-M3	2145842	B5CL4/0	2489555	C750-58	2398330	CAA400-M16	2760750
B-FL750	2598865	BKY-M3.5	2145845	B5CL400	2489575	C750-78	2398400	CAA50-M12	2760110
B-FL750ND	2598790	BKY-M3.5/1	2145847	B5CL500	2489580	C8-10	2395040	CAA500-M16-TNBD	2760852
B-TC250	2596266	BKY-M4	2145853	B5CL6	2489515	C8-12	2395120	CAA630-4M8	2760950
B-TC0250ND	2599540	BKY-M5	2145856	B5CL600	2489585	C8-14	2395060	CAA70-M12	2760150
B-TC320ND	2596285	BKY-M6/1	2145862	B5CL750	2489590	C8-38	2395100	CAA95-M12	2760190
B-TC320NDF	2596290	BKY-M8	2145871	B5CL8	2489510	C8-516	2395080	CB1820L	2598495
B-TC450	2599405	BKY-M10	2145874	C1/0-12	2396280	C8-8	2395020	CB1852L	2598514
B-TC4500	2599409	BKY-M12	2145878	C1/0-14	2396220	C10-C10	2490070	CB3662L	2870229
B-TC500	2598827	BKY-P8	2145930	C1/0-38	2396260	C120-C120	2490630	CBP-F405	2076535
B-TC5000D-SC	2596300	BKY-P10	2145932	C1/0-516	2396240	C150-C120	2490670	CBP-F408	2076540
B-TC500Y	2598815	BKY-P12	2145934	C1/0-58	2396320	C150-C150	2490690	CBP-F408P	2076543
B-TC550	2599420	BKY-PP12	2145940	C1/0-916	2396300	C16-C16	2490110	CBP-F608	2076545
B-TC650	2599440	BKY-PP12/25	2145942	C1-12	2396080	C185-C185	2490745	CBP-F608P	2076550
B-TC650-SC	2599430	BKY-PP16/23	2145944	C1-14	2396020	C185-C95	2490710	CBP-M3	2076310
B-TC950	2599460	BKY-PPL30	2145950	C1-38	2396060	C240-C120	2490760	CBP-M3.5	2076315
B-TD270	2598951	BKY-PPL46	2145952	C1-516	2396040	C25-C10	2490150	CBP-M3.5/1	2076320
B-TD410T	2598945	BKY-U3	2145900	C2/0-12	2396480	C25-C25	2490190	CBP-M4	2076325
B15MD	2598837	BKY-U3.5	2145903	C2/0-14	2396420	C35-C16	2490230	CBP-M5	2076335
B1300-C	2599350	BKY-U4	2145906	C2/0-34	2396540	C35-C35	2490270	CBP-M6	2076340
B1300-C-KV	2599388	BKY-U5	2145909	C2/0-38	2396460	C50-C25	2490350	CBP-M6/1	2076345
B1300-UC	2599365	BKY-U6	2145912	C2/0-516	2396440	C50-C50	2490390	CBP-M608	2076560
B1300L-C	2599358	BKY-U6/1	2145914	C2/0-58	2396520	C59	8420035	CBP-M7	2076350
B1300L-C-KV	2599380	BN-FA608	3031640	C2/0-916	2396500	C6-C6	2490030	CBP-M8	2076355
B1300PL	2598542	BN-FAB608	3031660	C2-10	2395820	C70-C25N	2490310	CBP-P10	2076455
B1350-C	2599320	BN-FAR608	3031680	C2-12	2395900	C70-C35	2490430	CBP-P12	2076460
B1350-C-KV	2599340	BN-M10	2152390	C2-14	2395840	C70-C70	2490470	CBP-P8	2076450
B1350L-C	2599327	BN-M12	2152430	C2-38	2395880	C95-C35	2490510	CBP-PP12	2076480
B1350L-C-KV	2599345	BN-M2	2152010	C250-12	2397080	C95-C70	2490550	CBP-PP12/25	2076490
B1350-UC	2599335	BN-M3	2152030	C250-14	2397020	C95-C95	2490590	CBP-PPL30	2076498
B450ND-BV	2596235	BN-M3.5	2152070	C250-34	2397140	C10-C10ST	2492070	CBP-U3	2076380
B500	2596205	BN-M3.5/1	2152110	C250-38	2397060	C120-C120ST	2492630	CBP-U3.5	2076385
B500-KV	2596207	BN-M4	2152150	C250-516	2397040	C150-C120ST	2492670	CBP-U4	2076395
B500ND	2596220	BN-M5	2152190	C250-58	2397120	C150-C150ST	2492690	CBP-U4/1	2076400
B540ND6	2599979	BN-M6	2152230	C250-78	2397160	C16-C16ST	2492110	CBP-U4/2	2076405
B550	2598968	BN-M6/1	2152270	C250-916	2397100	C185-C185ST	2492745	CBP-U4/3L	2076408
B600	2596215	BN-M7	2152310	C2-516	2395860	C185-C95ST	2492710	CBP-U5	2076410
B68M-P18	2590163	BN-M8	2152350	C3/0-12	2396680	C240-C120ST	2492760	CBP-U6	2076415
B68RC3-85	2597970	BN-MA608	3031740	C3/0-14	2396620	C25-C10ST	2492150	CC8-9	3041630
B68RC3-96	2597972	BN-P10	2153190	C3/0-34	2396740	C25-C25ST	2492190	CC9-12	3041632
B68RC3-120	2597974	BN-P12	2153230	C3/0-38	2396660	C35-C16ST	2492230	CDD6	2599940
B70M-P36	2596030	BN-P8	2153150	C3/0-516	2396640	C35-C35ST	2492270	CDD6-8	2599941
B70M-P36-CH	2596046	BN-PP12	2153270	C3/0-58	2396720	C50-C25ST	2492350	CFA2600	3031942
BA-3	2598424	BN-PP12/25	2153310	C3/0-916	2396700	C50-C50ST	2492390	CFA300	3031900
BF-BF5	2053630	BN-PP16/25	2153350	C300-12	2397360	C6-C6ST	2492030	CFA400	3031914
BF-BM5	2053660	BN-U10	2152910	C300-34	2397420	C70-C25NST	2492310	CFA600	3031928
BF-F405	2053560	BN-U12	2152950	C300-38	2397340	C70-C35ST	2492430	CFA8600	3031970
BF-F405P	2053565	BN-U3	2152630	C300-516	2397320	C70-C70ST	2492470	CFAR600	3031956
BF-F408	2053570	BN-U3.5	2152670	C300-58	2397400	C95-C35ST	2492510	CGP-F608	2076845
BF-F408P	2053575	BN-U3.5/1	2152680	C300-78	2397440	C95-C70ST	2492550	CGP-F608P	2076850
BF-F608	2053610	BN-U4	2152710	C300-916	2397380	C95-C95ST	2492590	CGP-M3	2076610
BF-F608P	2053620	BN-U4/1	2152730	C3-10	2395640	CA150R-2M14	2533010	CGP-M3.5	2076615
BF-FM608	2053690	BN-U4/2	2152732	C3-12	2395720	CA150R-M12	2532810	CGP-M4	2076625
BF-M10	2052390	BN-U5	2152750	C3-14	2395660	CA150R-M14	2532850	CGP-M5	2076635
BF-M12	2052430	BN-U6	2152790	C3-38	2395700	CA150S-2M14	2533330	CGP-M6	2076640
BF-M2	2052010	BN-U6/1	2152830	C350-12	2397540	CA150S-M12	2533210	CGP-M6/1	2076645
BF-M3	2052030	BN-U8	2152870	C350-34	2397600	CA150S-M14	2533250	CGP-M608	2076860
BF-M3.5	2052070	BP-M10	2046345	C350-38	2397520	CA200R-2M14	2533570	CGP-M7	2076650
BF-M3.5/1	2052110	BP-M12	2046350	C350-58	2397580	CA200R-M14	2533350	CGP-M8	2076660
BF-M4	2052150	BP-M2	2046305	C350-78	2397620	CA240R-2M14	2533850	CGP-M8/1	2076665
BF-M5	2052190	BP-M3	2046310	C350-916	2397560	CA240R-M14	2533770	CGP-M10	2076670
BF-M6	2052230	BP-M3.5	2046315	C3-516	2395680	CA25-2M12	2530210	CGP-P10	2076755
BF-M6/1	2052270	BP-M3.5/1	2046316	C3-8	2395620	CA25-2M8	2530130	CGP-P12	2076760
BF-M6/2	2052280	BP-M4	2046320	C4/0-12	2396880	CA25-M10	2530050	CGP-P14	2076765
BF-M608	2053650	BP-M5	2046325	C4/0-14	2396820	CA25-M12	2530090	CGP-PP12	2076780
BF-M608P	2053655	BP-M6	2046330	C4/0-34	2396940	CA25-M8	2530010	CGP-PP17	2076790
BF-M7	2052310	BP-M6/1	2046331	C4/0-38	2396860	CA315R-2M14	2534430	CGP-U3.5	2076685
BF-M8	2052350	BP-M6/2	2046332	C4/0-516	2396840	CA315R-M14	2534330	CGP-U4	2076695
BF-P10	2053250	BP-M7	2046335	C4/0-58	2396920	CA315S-2M14	2534610	CGP-U5	2076710
BF-P12	2053290	BP-M8	2046340	C4/0-916	2396900	CA315S-M14	2534530	CGP-U6	2076715
BF-P8	2053210	BP-P10	2046415	C400-12	2397740	CA405-2M12	2530510	CL1/0-10	2396385
BF-PP10	2053320	BP-P12	2046420	C400-34	2397800	CA405-M12	2530450	CL1/0-12	2396397
BF-PP12	2053330	BP-P8	2046410	C400-38	2397720	CA405-M16	2530490	CL1/0-38	2396394
BF-PP12/25	2053370	BP-PP12	2046440	C400-58	2397780	CA50R-2M12	2530870	CL1/0-516	2396391
BF-PP12/29	2053380	BP-PP12/25	2046445	C400-78	2397820	CA50R-M12	2530790	CL1/0-D14	2396360
BF-PP16/25	2053410	BP-PP12/29	2046450	C400-916	2397760	CA50S-2M12	2531190	CL1/0-D141	2396361
BF-PPL30	2053460	BP-PP16/25	2046455	C4-10	2395440	CA50S-M12	2531110	CL1/0-D38	2396370
BF-PPL46	2053465	BP-PPL30	2046470	C4-12	2395520	CA50S-M16	2531150	CL1/0-DN	2396375
BF-U10	2052910	BP-PPL46	2046475	C4-14	2395460	CA70-M12	2531870	CL1/OIH-10	2396405
BF-U12	2052950	BP-U10	2046565	C4-38	2395500	CA70S-2M12	2531510	CL1/OIH-12	2396413
BF-U3	2052630	BP-U12	2046570	C4-516	2395480	CA70S-M12	2531430	CL1/OIH-14	2396407
BF-U3.5	2052670	BP-U3	2046510	C4-8	2395420	CA70S-M16	2531470	CL1/OIH-38	2396411
BF-U3.5/1	2052671	BP-U3.5	2046515	C500-12	2397940	CA95R-2M14	2532230	CL1/OIH-516	2396409
BF-U4	2052710	BP-U3.5/1	2046516	C500-34	2398000	CA95R-M12	2532150	CL1/OIH-58	2396417
BF-U4/1	2052720	BP-U4	2046530	C500-38	2397920	CA95R-M14	2532190	CL1/OIH-916	2396415
BF-U4/2	2052730	BP-U4/1	2046531	C500-58	2397980	CA95S-2M14	2532610	CL1-10	2396183
BF-U5	2052750	BP-U4/2	2046540	C500-78	2398020	CA95S-M12	2532450	CL1-12	2396191
BF-U5/2	2052765	BP-U5	2046545	C500-916	2397960	CA95S-M14	2532490	CL1-516	2396187
BF-U6	2052790	BP-U6	2046555	C600-12	2398120	CA95S-M16	2532500	CL1-D14	2396160
BF-U6/1	2052830	BP-U6/1	2046556	C600-34	2398180	CAA10-M12	2760005	CL1-D141	2396161
BF-U8	2052870	BP-U8	2046560	C600-58	2398160	CAA120-M12	2760310	CL1-D38	2396170
BKF-BF4	2053632	B5CL1	2489535	C600-78	2398200	CAA150-M12	2760350	CL1-DN	2396175
BKF-BM4	2053662	B5CL1/0	2489540	C600-916	2398140	CAA16-M12	2760012	CL1IH-10	2396205
BKF-F405	2053562	B5CL2	2489530	C6-10	2395240	CAA185-M12	2760430	CL1IH-12	2396217

Type/Code Cross-Reference chart

Type	Code	Type	Code	Type	Code	Type	Code	Type	Code
CL1H-14	2396208	CL400H-58	2397914	CRP-M8	2076055	DSV25	2489025	ES24-RE	2470519
CL1H-38	2396214	CL400H-916	2397911	CRP-P10	2076155	DSV35	2489030	ES30-RE	2470520
CL1H-516	2396211	CL4-10	2395585	CRP-P12	2076160	DSV50	2489035	ES37-RE	2470521
CL2/0-12	2396594	CL4-12	2395597	CRP-P8	2076150	DSV70	2489040	ES40-RE	2470522
CL2/0-38	2396591	CL4-14	2395588	CRP-PP12	2076180	DSV95	2489045	ES48-RE	2470523
CL2/0-D14	2396560	CL4-38	2395594	CRP-PP12/1	2076185	DSV120	2489050	ES80-RE	2470524
CL2/0-D141	2396561	CL4-D14	2395560	CRP-PP12/2/3	2076190	DSV150	2489055	ES03-YE	2470550
CL2/0-D38	2396570	CL4-D141	2395561	CRP-PP14	2076195	DSV185	2489060	ES06-YE	2470551
CL2/0-DN	2396575	CL4-D38	2395570	CRP-PPL30	2076205	DSV240	2489065	ES1-YE	2470552
CL2/OIH-12	2396611	CL4-DN	2395575	CRP-U3	2076080	DSV300	2489070	ES2-YE	2470553
CL2/OIH-14	2396605	CL4H-10	2395605	CRP-U3.5	2076085	DSV400	2489075	ES3-YE	2470554
CL2/OIH-34	2396617	CL4H-12	2395617	CRP-U3.5/2	2076090	DSV500	2489080	ES5-YE	2470555
CL2/OIH-38	2396609	CL4H-14	2395608	CRP-U4	2076095	DSV625	2489085	ES10-YE	2470556
CL2/OIH-516	2396607	CL4H-38	2395614	CRP-U4/1	2076100	DSV800	2489090	ES14-YE	2470557
CL2/OIH-58	2396615	CL4H-516	2395611	CRP-U4/2	2076105	DSV1000	2489095	ES19-YE	2470558
CL2/OIH-916	2396613	CL500-12	2398088	CRP-U5	2076110	ECW-H3D	2630073	ES24-YE	2470559
CL2-10	2395985	CL500-58	2398094	CRP-U6	2076115	EK100	2597990	ES30-YE	2470560
CL2-12	2395997	CL500-D141	2398061	CRP-U6/1	2076120	EK500P	2597992	ES37-YE	2470561
CL2-14	2395988	CL500-D38	2398070	CRP-U8	2076125	EKLOEPA12	2847000	ES40-YE	2470562
CL250-12	2397204	CL500-DN	2398075	CS-CPE-1	2592748	EKLOS	2848001	ES48-YE	2470563
CL250-D38	2397180	CL500H-12	2398108	CVB-001	2593300	EKL1BEPA12	2847002	ES80-YE	2470564
CL250-DN	2397185	CL500H-34	2398117	CVB-007	2593295	EKL15	2848003	F1-15	2599865
CL250H-12	2397229	CL500H-38	2398105	CVB-010	2593298	EKL2EPA12	2847004	FD11	3017354
CL250H-14	2397220	CL500H-58	2398114	CVB-011	2593299	EKL25	2848010	FD13.5	3017356
CL250H-34	2397238	CL500H-916	2398111	CVB-013	2593294	EKL3EM4PA12	2847006	FD16	3017358
CL250H-38	2397226	CL600-12	2398285	CVB-031	2593312	EKL35	2848007	FD21	3017360
CL250H-516	2397223	CL600-58	2398291	CVB-037	2593315	EKL4BEPA12	2847008	FD29	3017362
CL250H-58	2397235	CL600-D38	2398270	DR6-5	2387910	EKL4BESVCE	2848009	FD36	3017364
CL250H-916	2397232	CL600-DN	2398275	DR6-6	2387920	ELB-3	2598422	FD42	3017366
CL2-516	2395991	CL600H-12	2398305	DR6-8	2387930	EPB-1N	2598453	FD48	3017368
CL2-D14	2395960	CL600H-34	2398314	DR10-5	2388000	ERCH	2596112	FD7	3017350
CL2-D141	2395961	CL600H-58	2398311	DR10-6	2388005	ERCH-WH	2596114	FD9	3017352
CL2-D38	2395970	CL600H-916	2398308	DR10-8	2388010	ES03-BU	2470410	FDM12	3017375
CL2-DN	2395975	CL6-10	2395385	DR10-10	2388015	ES06-BU	2470411	FDM16	3017374
CL2-DN38	2395971	CL6-12	2395397	DR16-6	2388030	ES1-BU	2470412	FDM20	3017377
CL2H-10	2396005	CL6-14	2395388	DR16-8	2388040	ES2-BU	2470413	FDM25	3017379
CL2H-12	2396017	CL6-D14	2395360	DR16-10	2388050	ES3-BU	2470414	FDM32	3017381
CL2H-14	2396008	CL6-D141	2395361	DR16-12	2388060	ES5-BU	2470415	FDM40	3017383
CL2H-38	2396014	CL6-D38	2395370	DR25-6	2388110	ES10-BU	2470416	FDM50	3017385
CL2H-516	2396011	CL6-DN	2395375	DR25-8	2388120	ES14-BU	2470417	FDM63	3017387
CL3/0-12	2396794	CL6H-10	2395405	DR25-10	2388130	ES19-BU	2470418	FL10-150	2510070
CL3/0-D141	2396761	CL6H-12	2395417	DR25-12	2388140	ES24-BU	2470419	FL10-200	2510150
CL3/0-D38	2396770	CL6H-14	2395408	DR25-16	2388160	ES30-BU	2470420	FL10-250	2510190
CL3/0-DN	2396775	CL6H-38	2395414	DR35-6	2388210	ES37-BU	2470421	FL16-150	2510470
CL3/OIH-12	2396811	CL6H-516	2395411	DR35-8	2388220	ES40-BU	2470422	FL16-200	2510550
CL3/OIH-14	2396805	CL750-12	2398485	DR35-10	2388230	ES48-BU	2470423	FL16-250	2510590
CL3/OIH-34	2396817	CL750-58	2398488	DR35-12	2388240	ES80-BU	2470424	FL16-320	2510670
CL3/OIH-38	2396809	CL750-D38	2398470	DR35-16	2388246	ES03-GY	2470430	FL16-350	2510690
CL3/OIH-516	2396807	CL750-DN	2398475	DR50-6	2388250	ES06-GY	2470431	FL16-420	2510710
CL3/OIH-58	2396815	CL750-DN38	2398471	DR50-8	2388255	ES1-GY	2470432	FL16-570	2510750
CL3/OIH-916	2396813	CL750H-12	2398505	DR50-10	2388260	ES2-GY	2470433	FL16-660	2510790
CL300-12	2397491	CL750H-34	2398511	DR50-12	2388270	ES3-GY	2470434	FL25-150	2510950
CL300-D38	2397470	CL750H-58	2398508	DR50-14	2388280	ES5-GY	2470435	FL25-200	2511070
CL300-DN	2397475	CL8-10	2395183	DR50-16	2388290	ES10-GY	2470436	FL25-300	2511110
CL300H-12	2397509	CL8-14	2395186	DR70-8	2388320	ES14-GY	2470437	FL25-350	2511190
CL300H-34	2397515	CL8-38	2395192	DR70-10	2388330	ES19-GY	2470438	FL10-150ST	2518510
CL300H-38	2397507	CL8-D14	2395160	DR70-12	2388340	ES24-GY	2470439	FL10-200ST	2518550
CL300H-516	2397505	CL8-D141	2395161	DR70-14	2388350	ES30-GY	2470440	FL10-250ST	2518590
CL300H-58	2397513	CL8-D38	2395170	DR70-16	2388360	ES37-GY	2470441	FL16-150ST	2518870
CL300H-916	2397511	CL8H-10	2395203	DR70-20	2388380	ES40-GY	2470442	FL16-200ST	2518910
CL3-12	2395797	CL8H-12	2395215	DR95-8	2388390	ES48-GY	2470443	FL16-250ST	2518950
CL3-14	2395788	CL8H-14	2395206	DR95-10	2388395	ES80-GY	2470444	FL16-320ST	2518990
CL3-38	2395794	CL8H-38	2395212	DR95-12	2388400	ES03-BR	2470450	FL16-350ST	2519030
CL350-12	2397688	CL8H-516	2395209	DR95-14	2388410	ES06-BR	2470451	FL16-420ST	2519070
CL350-D141	2397661	CMA600	3031984	DR95-16	2388420	ES1-BR	2470452	FL16-570ST	2519150
CL350-D38	2397670	CMB1	2599943	DR95-20	2388430	ES2-BR	2470453	FL16-660ST	2519170
CL350-DN	2397675	CMB2	2599945	DR120-8	2388450	ES3-BR	2470454	FL25-150ST	2519530
CL350H-12	2397708	CP1086-W-1000-KV	2597905	DR120-10	2388460	ES5-BR	2470455	FL25-200ST	2519570
CL350H-34	2397717	CP1096	2597700	DR120-12	2388470	ES10-BR	2470456	FL25-250ST	2519610
CL350H-38	2397705	CP1096-W-1000-KV	2597695	DR120-16	2388490	ES14-BR	2470457	FL25-300ST	2519690
CL350H-58	2397714	CP1120	2597962	DR120-20	2388500	ES19-BR	2470458	FLS3	3026810
CL350H-916	2397711	CP1120-W-1000-KV	2597958	DR150-10	2388530	ES24-BR	2470459	FLS5	3026815
CL3-516	2395791	CP1131	2610120	DR150-12	2388540	ES30-BR	2470460	G80X2.4	3041700
CL3-D38	2395770	CPE-1	2592751	DR150-16	2388560	ES37-BR	2470461	G80X2.4N	3041701
CL3-DN	2395775	CPE-1-110	2592752	DR150-20	2388570	ES40-BR	2470462	G80X2.4/M	3041702
CL3H-10	2395805	CPKD108	2808582	DR185-10	2388600	ES48-BR	2470463	G80X2.4N/M	3041703
CL3H-12	2395817	CPKD1508	2808587	DR185-12	2388610	ES80-BR	2470464	G90X2.4	3041705
CL3H-14	2395808	CPKD2508	2808592	DR185-16	2388620	ES03-BK	2470470	G90X2.4N	3041706
CL3H-38	2395814	CPKD508	2808573	DR185-20	2388630	ES06-BK	2470471	G90X2.4V0	3041709
CL3H-516	2395811	CPKD7508	2808578	DR240-10	2388710	ES1-BK	2470472	G100X2.5	3041710
CL4/0-12	2396994	CPP-0	2592671	DR240-12	2388720	ES2-BK	2470473	G100X2.5N	3041711
CL4/0-38	2396991	CPU1131-C	2610150	DR240-16	2388730	ES3-BK	2470474	G100X2.5/M	3041712
CL4/0-D141	2396961	CPU1230-3D	2630200	DR240-20	2388740	ES5-BK	2470475	G100X2.5/MV0	3041714
CL4/0-D38	2396970	CRP-F305	2076225	DR300-10	2388780	ES10-BK	2470476	G100X2.5/M/M	3041713
CL4/0-DN	2396975	CRP-F308	2076230	DR300-12	2388790	ES14-BK	2470477	G120X2.5	3041715
CL4/0-DN38	2396971	CRP-F405	2076235	DR300-16	2388810	ES19-BK	2470478	G120X2.5N	3041716
CL4/OIH-12	2397011	CRP-F405P	2076237	DR300-20	2388820	ES24-BK	2470479	G140X2.5	3041720
CL4/OIH-14	2397005	CRP-F408	2076240	DR400-12	2388870	ES30-BK	2470480	G140X2.5N	3041721
CL4/OIH-34	2397017	CRP-F408P	2076242	DR400-16	2388890	ES37-BK	2470481	G140X2.5/M	3041722
CL4/OIH-38	2397009	CRP-F608	2076245	DR400-20	2388900	ES40-BK	2470482	G140X2.5/MV0	3041724
CL4/OIH-516	2397007	CRP-F608P	2076250	DR500-12	2388950	ES48-BK	2470483	G140X2.5/M/M	3041723
CL4/OIH-58	2397015	CRP-M3	2076010	DR500-16	2388970	ES80-BK	2470484	G160X2.5	3041725
CL4/OIH-916	2397013	CRP-M3.5	2076015	DR500-20	2388980	ES03-RE	2470510	G160X2.5N	3041726
CL400-12	2397888	CRP-M3.5/1	2076020	DR625-12	2389030	ES06-RE	2470511	G160X2.5/M	3041727
CL400-58	2397894	CRP-M4	2076025	DR625-16	2389050	ES1-RE	2470512	G160X2.5N/M	3041728
CL400-D141	2397861	CRP-M4/3	2076030	DR625-20	2389060	ES2-RE	2470513	G200X2.5	3041730
CL400-D38	2397870	CRP-M5	2076035	DR800-20	2389110	ES3-RE	2470514	G200X2.5N	3041731
CL400-DN	2397875	CRP-M6	2076040	DR1000-20	2389130	ES5-RE	2470515	G200X2.5/M	3041732
CL400H-12	2397908	CRP-M6/1	2076045	DSV6	2489010	ES10-RE	2470516	G200X2.5/MV0	3041734
CL400H-34	2397917	CRP-M608	2076260	DSV10	2489015	ES14-RE	2470517	G200X2.5N/M	3041733
CL400H-38	2397905	CRP-M7	2076050	DSV16	2489020	ES19-RE	2470518	G250X2.8	3041735

Type/Code Cross-Reference chart

Type	Code	Type	Code	Type	Code	Type	Code	Type	Code
G250X2.8N	3041736	G880X12.6N	3041946	GP-M7	2046635	HR50-8	2385145	KE508ST	2802070
G300X2.8	3041740	G1030X12.6	3041950	GP-M8	2046640	HR50-10	2385150	KE610ST	2802990
G300X2.8N	3041741	G1030X12.6N	3041951	GP-M8/1	2046641	HR50-12	2385155	KE612ST	2803030
G120X3.6	3041745	GA-3	2598429	GP-P10	2046715	HR50-14	2385160	KE616ST	2803070
G120X3.6N	3041746	GF-F608	2055630	GP-P12	2046720	HR50-16	2385165	KE7506ST	2802110
G140X3.6	3041750	GF-F608P	2055650	GP-P14	2046725	HR70-6	2385175	KE7508ST	2802150
G140X3.6N	3041751	GF-M10	2054250	GP-PP12	2046740	HR70-8	2385180	KIT-B1300-C-1	2599318
G140X3.6/M	3041753	GF-M10/1	2054290	GP-PP17	2046750	HR70-10	2385185	KIT-B1300-C-2	2599319
G140X3.6N/M	3041752	GF-M12	2054330	GP-PPL46	2046755	HR70-12	2385190	KIT-B1300-C-MK	2599349
G150X3.6	3041755	GF-M14	2054370	GP-U10	2046865	HR70-14	2385195	KIT-B500-1	2596201
G150X3.6N	3041756	GF-M16	2054410	GP-U10/1	2046866	HR70-16	2385200	KIT-B500-2	2596202
G150X3.6V0	3041759	GF-M3	2054010	GP-U12	2046870	HR95-8	2385210	KIT-B500-MK	2596203
G180X3.6	3041760	GF-M3.5	2054030	GP-U14	2046875	HR95-10	2385215	KIT-B500ND-1	2596225
G180X3.6N	3041761	GF-M4	2054070	GP-U16	2046880	HR95-12	2385220	KIT-B-FL750-1	2598860
G200X3.6	3041765	GF-M5	2054110	GP-U3.5	2046825	HR95-14	2385225	KIT-HT131-C-1	2610380
G200X3.6N	3041766	GF-M6	2054150	GP-U4	2046830	HR95-16	2385230	KIT-HT131-C-2	2610381
G200X3.6/M	3041767	GF-M6/1	2054160	GP-U5	2046845	HR95-20	2385235	KIT-HT131-C-MK	2610382
G200X3.6N/M	3041768	GF-M608	2055670	GP-U6	2046855	HR120-8	2385240	KIT-HT51-1	2670601
G250X3.6	3041770	GF-M7	2054170	GP-U8	2046860	HR120-10	2385245	KIT-HT51-2	2670600
G250X3.6N	3041771	GF-M8	2054210	GR100X7.6N	3042620	HR120-12	2385250	KIT-HT51-MK	2670599
G300X3.6	3041775	GF-M8/1	2054220	GR120X7.6N	3042625	HR120-14	2385255	KIT-HT-FL75-1	2665031
G300X3.6N	3041776	GF-P10	2055310	GR150X7.6N	3042630	HR120-16	2385260	KIT-2.5EPB1N	2598463
G300X3.6/M	3041777	GF-P12	2055350	GR200X7.6N	3042635	HR120-20	2385265	KIT-4EPB1N	2598464
G300X3.6N/M	3041778	GF-P14	2055370	GR250X7.6N	3042640	HR150-8	2385270	KIT-HWE1	8420012
G370X3.6	3041780	GF-PP12	2055390	GR300X7.6N	3042645	HR150-10	2385275	KT1	2591319
G370X3.6N	3041781	GF-PP17	2055430	GR370X7.6N	3042650	HR150-12	2385280	KT2	2591320
G120X4.8	3041785	GF-PPL46	2055465	GX200X4.5	3042245	HR150-14	2385285	KT3N	2591276
G120X4.8N	3041786	GF-U10	2054810	GX300X4.5	3042250	HR150-16	2385290	KT4N	2591278
G160X4.8	3041790	GF-U10/1	2054850	GX370X4.5	3042255	HR150-20	2385295	KT5	2591279
G160X4.8N	3041791	GF-U12	2054890	GX370X7.9	3042260	HR185-10	2385305	KTS1632	2590700
G190X4.8	3041795	GF-U14	2054930	GX520X4.5	3042257	HR185-12	2385310	L03-M	2480020
G190X4.8N	3041796	GF-U16	2054970	GX680X7.9	3042265	HR185-14	2385315	L03-P	2485010
G190X4.8/M	3041797	GF-U3.5	2054610	GX1020X7.9	3042270	HR185-16	2385320	L06-M	2480050
G190X4.8N/M	3041798	GF-U4	2054650	GXAC125X4.6	3042310	HR185-20	2385325	L06-P	2485040
G200X4.8	3041800	GF-U5	2054690	GXAC150X4.6	3042312	HR240-10	2385335	L10-M	2480330
G200X4.8N	3041801	GF-U6	2054730	GXAC200X4.6	3042314	HR240-12	2385340	L10-P	2485270
G200X4.8/M	3041802	GF-U8	2054770	GXAC260X4.6	3042316	HR240-14	2385345	L10-T	2486820
G200X4.8/MV0	3041804	GFHT112X2.5	3042805	GXAC290X4.6	3042318	HR240-16	2385350	L100-M	2480930
G200X4.8N/M	3041803	GFHT100X2.5	3042810	GXAC360X4.6	3042320	HR240-20	2385355	L120-M	2481010
G250X4.8	3041805	GH8	3041550	GXAC520X4.6	3042322	HS56	8420033	L120-T	2486890
G250X4.8N	3041806	GK-F608	2145500	GXAC680X4.6	3042324	HSV10	2488015	L14-M	2480410
G250X4.8/M	3041807	GK-F608P	2145502	GXAC840X4.6	3042326	HSV16	2488020	L14-P	2485350
G250X4.8N/M	3041808	GKF-M608	2055672	GXAC200X7.9	3042350	HSV25	2488025	L16-T	2486830
G280X4.8	3041810	GKY-M3.5	2145982	GXAC290X7.9	3042352	HSV35	2488030	L150-T	2486900
G280X4.8N	3041811	GKY-M4	2145985	GXAC360X7.9	3042354	HSV50	2488035	L160-M	2481050
G300X4.8	3041815	GKY-M5	2145988	GXAC520X7.9	3042356	HSV70	2488040	L185-T	2486910
G300X4.8N	3041816	GKY-M6	2145991	GXAC680X7.9	3042358	HSV95	2488045	L19-M	2480490
G370X4.8	3041820	GKY-M8	2145994	GXAC840X7.9	3042360	HSV120	2488050	L19-P	2485430
G370X4.8V0	3041824	GKY-M10	2145997	HB2	2591308	HSV150	2488055	L1-M	2480090
G370X4.8N	3041821	GKY-M12	2146000	HB5	2591318	HSV185	2488060	L1-P	2485070
G390X4.8	3041825	GKY-M14	2146003	HB6	2591285	HSV240	2488065	L200-M	2481090
G390X4.8N	3041826	GKY-M16	2146006	HB7	2591310	HT-FL74	2665028	L24-M	2480570
G430X4.8	3041830	GKY-P14	2146040	HB8	2591284	HT-FL75	2665030	L24-P	2485510
G430X4.8V0	3041834	GKY-PP12	2146045	HB9	2591336	HT-TC026	2591406	L240-T	2486920
G430X4.8N	3041831	GKY-PP17	2146047	HB10	2591337	HT-TC026Y	2591408	L25-T	2486840
G450X4.8	3041835	GKY-PPL46	2146055	HB11	2591343	HT-TC041N	2591427	L2-M	2480130
G450X4.8N	3041836	GKY-U3.5	2146020	HB12N	2591345	HT-TC051	2591472	L2-P	2485100
G530X4.8	3041840	GKY-U4	2146023	HB13UE	2591347	HT-TC051Y	2591475	L30-M	2480650
G530X4.8N	3041841	GKY-U5	2146026	HF1	2590900	HT-TC055	2591445	L30-P	2485590
G150X7.6	3041845	GKY-U6	2146029	HF2	2590905	HT-TC065	2591477	L300-T	2486930
G150X7.6N	3041846	GKY-U8	2146032	HN1	2590300	HT-TC0851	2591496	L35-T	2486850
G200X7.6	3041850	GN-M10	2154250	HN5	2590291	HT120	2610420	L37-M	2480730
G200X7.6N	3041851	GN-M10/1	2154290	HN-A25	2590401	HT120-KV	2610430	L37-P	2485670
G250X7.6	3041855	GN-M12	2154330	HN-D25	2590403	HT131-C	2610416	L3-M	2480170
G250X7.6N	3041856	GN-M14	2154370	HN-H25	2590405	HT131-UC	2610436	L3-P	2485130
G300X7.6	3041860	GN-M16	2154410	HN-T25	2590407	HT131LN-C	2610419	L4-T	2486805
G300X7.6N	3041861	GN-M3	2154010	HNKE4	2590299	HT45-E	2650040	L400-T	2486940
G370X7.6	3041865	GN-M3.5	2154030	HNKE16	2590329	HT51	2670610	L48-M	2480810
G370X7.6N	3041866	GN-M4	2154070	HNKE50	2590342	HT51-KV	2670611	L48-P	2485680
G430X7.6	3041870	GN-M5	2154110	HNN3	2590296	HT61	2670235	L5-M	2480210
G430X7.6N	3041871	GN-M6	2154150	HNN4	2590292	HT81-U	2600036	L5-P	2485160
G530X7.6	3041875	GN-M6/1	2154160	HP1	2590500	HWE-1	8420010	L50-T	2486860
G530X7.6N	3041876	GN-M7	2154170	HP1-1	2590502	HX1	2590298	L6-T	2486810
G430X9.0	3041880	GN-M8	2154210	HP3	2590531	I38-F	6060130	L60-M	2480850
G430X9.0N	3041881	GN-M8/1	2154220	HP3-1	2590532	I38-MS	6060128	L60-P	2485690
G530X9.0	3041885	GN-P10	2155250	HP4-B	2590032	IDT	2590920	L7-M	2480250
G530X9.0N	3041886	GN-P12	2155290	HP4-C10	2590040	IT6	8420016	L7-P	2485190
G710X9.0	3041890	GN-P14	2155310	HP4-G	2590033	KE0.75-1	2591050	L70-T	2486870
G710X9.0N	3041891	GN-PP12	2155330	HP4-R	2590031	KE10-1	2591049	L80-M	2480890
G710X9.0V0	3041894	GN-PP17	2155370	HPH-1	2590029	KE10165T	2803150	L95-T	2486880
G780X9.0	3041895	GN-U10	2154850	HR10-6	2385025	KE1065T	2802310	M108-520	2648752
G780X9.0N	3041896	GN-U10/1	2154890	HR10-8	2385030	KE1105T	2802390	M108-C	2611860
G830X9.0	3041900	GN-U12	2154930	HR10-10	2385035	KE1508ST	2802510	M108.215-U	2603723
G830X9.0N	3041901	GN-U14	2154970	HR10-12	2385040	KE15105T	2802550	M110-520	2648754
G920X9.0	3041905	GN-U16	2155010	HR16-5	2385047	KE16-15	2599861	M113	2651130
G920X9.0N	3041906	GN-U3.5	2154650	HR16-6	2385050	KE16165T	2803190	M113-50	2675855
G1020X9.0	3041910	GN-U4	2154690	HR16-8	2385055	KE1A-3	2598430	M113-C	2611870
G1020X9.0N	3041911	GN-U5	2154730	HR16-10	2385060	KE2.5-1	2591048	M113.173-U	2603730
G1220X9.0	3041915	GN-U6	2154770	HR16-12	2385065	KE2.5A-3	2598432	M118	2651150
G1220X9.0N	3041916	GN-U8	2154810	HR25-6	2385075	KE250155T	2803455	M118-50	2675860
G230X12.6	3041920	GP-M10	2046645	HR25-8	2385080	KE250185T	2803460	M118-C	2611910
G230X12.6N	3041921	GP-M10/1	2046646	HR25-10	2385085	KE25085T	2802670	M118.158-U	2603725
G380X12.6	3041925	GP-M12	2046650	HR25-12	2385090	KE25105T	2802710	M140	2651170
G380X12.6N	3041926	GP-M14	2046655	HR25-14	2385095	KE35-15	2599862	M140-50	2675870
G480X12.6	3041930	GP-M16	2046660	HR35-6	2385105	KE350125T	2803470	M140-C	2612010
G480X12.6N	3041931	GP-M3	2046610	HR35-8	2385110	KE350155T	2803475	M140.190-U	2603800
G580X12.6	3041935	GP-M3.5	2046615	HR35-10	2385115	KE350185T	2803480	M145-520	2648770
G580X12.6N	3041936	GP-M4	2046620	HR35-12	2385120	KE4-15	2599860	M158	2651200
G730X12.6	3041940	GP-M5	2046625	HR35-14	2385125	KE4105T	2802870	M158-50	2675880
G730X12.6N	3041941	GP-M6	2046630	HR35-16	2385130	KE4125T	2802910	M158-C	2612130
G880X12.6	3041945	GP-M6/1	2046631	HR50-6	2385140	KE5065T	2802030	M160-520	2648771

Type/Code Cross-Reference chart

Type	Code	Type	Code	Type	Code	Type	Code	Type	Code
M173	2651210	MA10-19-U	2600290	ME100-520	2648552	MK6-50	2675370	MPC1	2595201
M173-50	2675890	MA100-3D	2631790	ME12	2652150	MK8-50	2675390	MPC2	2595203
M173-C	2612230	MA100-520	2645690	ME12-50	2676070	MK10-50	2675410	MPC4	2595208
M173L-C	2612240	MA12-50	2675668	ME12-C	2614213	MK12-50	2675430	MPC7	2595221
M190-50	2675900	MA12-C	2610870	ME12.17-U	2604850	MK14-50	2675450	MQ10-50	2675010
M190-520	2648772	MA12.20-U	2600310	ME120-3D	2634950	MK16-50	2675470	MQ16-50	2675013
M190-C	2612330	MA120-3D	2631810	ME120-520	2648554	MK18-50	2675490	MQ25-50	2675016
M208-C	2612420	MA120-520	2645711	ME14	2652170	MK20-50	2675510	MQ35-50	2675019
M208-U	2603780	MA14-50	2675670	ME14-50	2676080	MK22-50	2675530	MQ50-50	2675021
M215-50	2675910	MA14-C	2610880	ME14-C	2614215	MK22L	2651791	MQ70-50	2675024
M215-520	2648773	MA160-520	2645731	ME160-520	2648556	MK22L-50	2675534	MQM10-C	2610661
M215-C	2612490	MA17-50	2675672	ME17	2652190	MK25-50	2675550	MQM16-C	2610662
M220-520	2648774	MA17-C	2610890	ME17-50	2676090	MK28-50	2675560	MQM25-C	2610663
M232-C	2612590	MA19-50	2675674	ME17-C	2614217	MK28-60	2671460	MQM35-C	2610664
M255-520	2648776	MA19-C	2610900	ME19	2652210	MK32-50	2675564	MQM50-C	2610665
M295-520	2648780	MA19-U	2600320	ME19-50	2676100	MK6-C	2614250	MQM70-C	2610666
M340-520	2648784	MA2-C	2610810	ME19-C	2614219	MK8-C	2614260	MQM95-C	2610667
M440-520	2648840	MA2.3	2650130	ME2	2652030	MK10-C	2614270	MQM120-C	2610668
M540-520	2648910	MA2.3-50	2675660	ME2/3-15	2599876	MK12-C	2614280	MQM150-C	2610669
M70	2651090	MA20-50	2675675	ME2-50	2676010	MK14-C	2614290	MQM185-C	2610670
M70-50	2675800	MA20-C	2610910	ME2-C	2614201	MK16-C	2614300	MQM240-C	2610671
M70-C	2611590	MA200-520	2645750	ME2.19-U	2604750	MK18-C	2614310	MQS16-C	2610752
M70.140-U	2603710	MA24-50	2675676	ME20	2652230	MK20-C	2614320	MQS35-C	2610753
M75	2651100	MA24-C	2610920	ME20-50	2676110	MK22-C	2614330	MQS70-C	2610754
M75-50	2675805	MA24-U	2600330	ME200-520	2648558	MK25-C	2614340	MQS150-C	2610755
M75-C	2611650	MA29-C	2610930	ME20-C	2614221	MK28-C	2614350	MQS240-C	2610756
M75.96-U	2603715	MA29.80-U	2600360	ME24	2652250	MK32-C	2614360	MS4/10-15	2599880
M96	2651110	MA3-C	2610820	ME24L	2652251	MK34L-C	2614371	MS10/16-15	2599881
M96-50	2675850	MA3.5-U	2600210	ME24-50	2676120	ML95-240-12C	2752175	MT-FC48N	2685903
M96-C	2611800	MA30-80-U	2600380	ME24L-50	2676121	ML95-240-16C	2752177	MT150R-C12	2545010
M20AH-600	2649235	MA30-C	2610940	ME24-C	2614223	ML150-240-12C	2752180	MT150R-C16	2545090
M24AH-600	2649237	MA35-C	2610950	ME29	2652260	ML150-240-16C	2752182	MT150R-GC	2541870
M27AH-600	2649239	MA35-U	2600390	ME29-50	2676130	MLA50-240-12C	2752170	MT150R-TD	2540550
M30AH-600	2649241	MA37-C	2610960	ME29-C	2614225	MLL1	2598002	MT150S-C12	2545310
M34AH-600	2649243	MA37-U	2600410	ME29-U	2604870	MLL90	2590812	MT150S-C14-80	2546270
M36AH-600	2649245	MA40-C	2610970	ME3	2652050	MLRJ1	2590815	MT150S-C16	2545350
M38AH-600	2649247	MA40-U	2600430	ME3-50	2676020	MLS1	2590805	MT150S-GC	2541910
M40AH-600	2649249	MA48-C	2610980	ME3-C	2614203	MLS2	2590807	MT150S-TD	2540630
M74AH-600	2649253	MA48-U	2600450	ME3.14-U	2604770	MMT200-50	2676388	MT200R-C10	2545540
M75AH-600	2649255	MA5	2650150	ME30	2652270	MMT200-C	2611190	MT200R-C16	2545550
M76AH-600	2649257	MA5-50	2675662	ME30L	2652271	MMT200-U	2601170	MT200R-GC	2542030
M7CD-600	2649205	MA5-C	2610830	ME30-50	2676140	MMT25-50	2676380	MT200R-TD	2540670
M8CD-600	2649207	MA60-C	2610990	ME30L-50	2676141	MMT25-C	2611160	MT240R-C12	2545710
M9CD-600	2649209	MA7	2650170	ME30-C	2614227	MMT25-U	2601050	MT240R-C16	2545750
M10CD-600	2649211	MA7-50	2675664	ME30-U	2604890	MMT315-C	2611200	MT240R-GC	2542110
M11CD-600	2649213	MA7-C	2610840	ME35-50	2676150	MMT50-50	2676382	MT240R-TD	2540710
M12CD-600	2649215	MA7.14-U	2600250	ME35-C	2614229	MMT50-C	2611170	MT25-C8	2543030
M13CD-600	2649217	MA80-3D	2631770	ME35-U	2604910	MMT50-U	2601090	MT25-GC	2541570
M14CD-600	2649219	MA80-520	2645671	ME37-50	2676160	MMT95-50	2676384	MT25-TD	2540150
M15CD-600	2649221	MA9	2650180	ME37-C	2614231	MMT95-C	2611180	MT315R-C16	2545950
M16CD-600	2649223	MA9-50	2675665	ME37-U	2604930	MMT95-U	2601130	MT315R-GC	2542150
M17CD-600	2649225	MA9-C	2610850	ME40-50	2676165	MMN10-C	2610560	MT315R-TD	2540750
M10SH-600	2649265	MA9.17-U	2600270	ME40-C	2614233	MMN10RF-50	2676250	MT315S-C16	2545990
M12SH-600	2649267	MB2-80U	2604350	ME40-U	2604950	MMN10RF-C	2610768	MT315S-GC	2542290
M14SH-600	2649269	MB3-80U	2604400	ME48-50	2676170	MMN12-C	2610570	MT315S-TD	2540790
M16SH-600	2649271	MBS50-240-C	2777030	ME48-C	2614235	MMN12F-50	2676260	MT400-TD	2540830
M18SH-600	2649273	MBS95-240-C	2777032	ME48-U	2604970	MMN12F-C	2610770	MT405-C10	2543410
M20SH-600	2649275	MC0	2650490	ME5	2652070	MMN14-C	2610580	MT405-C14-80	2546070
M74SH-600	2649277	MC0-U	2603510	ME5-50	2676030	MMN14RF-50	2676270	MT405-C8	2543400
M75SH-600	2649279	MC02-U	2603550	ME5-C	2614205	MMN14RF-C	2610772	MT405-GC	2541610
M76SH-600	2649281	MC10	2650530	ME5.7-U	2604790	MMN17-C	2610591	MT405-TD	2540190
M76.15H-600	2649283	MC10-50	2675610	ME60-50	2676172	MMN17F-50	2676280	MT500-TD	2540870
M20AH-1000	2649570	MC10-C	2611100	ME60-C	2614237	MMN17F-C	2610774	MT50R-C10	2543650
M24AH-1000	2649572	MC10-U	2600610	ME7	2652090	MMN19-C	2610600	MT50R-C8	2543610
M27AH-1000	2649574	MC185-3D	2632030	ME7-50	2676040	MMN19RF-50	2676285	MT50R-GC	2541690
M30AH-1000	2649576	MC185-C	2611150	ME7-C	2614207	MMN19RF-C	2610776	MT50R-TD	2540270
M34AH-1000	2649578	MC2	2650500	ME80-3D	2634930	MMN2-C	2610511	MT50S-C10	2543850
M36AH-1000	2649580	MC240-3D	2632035	ME80-520	2648550	MMN20-C	2610610	MT50S-C14-80	2546110
M38AH-1000	2649582	MC25	2650550	ME80-C	2614239	MMN20F-50	2676290	MT50S-C8	2543810
M40AH-1000	2649584	MC25-50	2675620	ME9	2652110	MMN20F-C	2610778	MT50S-GC	2541650
M42AH-1000	2649586	MC25-C	2611110	ME9-50	2676050	MMN24-C	2610620	MT50S-TD	2540230
M44AH-1000	2649588	MC25-U	2600650	ME9-C	2614209	MMN24RF-50	2676295	MT630-TD	2540890
M48AH-1000	2649590	MC3	8420018	ME9.20-U	2604810	MMN24RF-C	2610780	MT705-C10	2544050
M76AH-1000	2649592	MC35	2650570	MFB13-40	2598040	MMN29-C	2610625	MT705-GC	2541730
M7CD-1000	2649510	MC35-50	2675630	MFB50-63	2598045	MMN29F-C	2610782	MT705-TD	2540350
M8CD-1000	2649512	MC35-C	2611120	MH10/16-15	2599886	MMN2RF-50	2676210	MT95R-C10	2544290
M9CD-1000	2649514	MC35-U	2600690	MK175-C	2614307	MMN2RF-C	2610760	MT95R-C12	2544330
M10CD-1000	2649516	MC4	8420019	MK14-3D	2634781	MMN3-C	2610520	MT95R-GC	2541770
M11CD-1000	2649518	MC6	2650510	MK16-3D	2634783	MMN30-C	2610630	MT95R-TD	2540390
M12CD-1000	2649520	MC6-50	2675605	MK18-3D	2634785	MMN30RF-C	2610784	MT95S-C10	2544530
M13CD-1000	2649522	MC6.25-U	2600630	MK20-3D	2634786	MMN35-C	2610635	MT95S-C12	2544570
M14CD-1000	2649524	MC70-3D	2632010	MK22-3D	2634787	MMN35F-C	2610786	MT95S-C14-80	2546230
M15CD-1000	2649526	MC70-50	2675640	MK25-3D	2634788	MMN37-C	2610640	MT95S-GC	2541850
M16CD-1000	2649528	MC70-80U	2600720	MK28-3D	2634790	MMN37RF-C	2610788	MT95S-TD	2540470
M17CD-1000	2649530	MC70-C	2611130	MK32-3D	2634800	MMN3RF-50	2676220	MTA16-C	2770001
M18CD-1000	2649532	MC95-3D	2632020	MK34-3D	2634810	MMN3RF-C	2610762	MTA25-C	2770020
M19CD-1000	2649534	MC95-80U	2600730	MK38-3D	2634830	MMN48-C	2610650	MTA35-C	2770030
M20CD-1000	2649536	MC95-C	2611140	MK42-3D	2634850	MMN48RF-C	2610790	MTA50-C	2770310
M10SH-1000	2649550	MCCC16-C	2617050	MK44-3D	2634870	MMN5-C	2610530	MTA70-C	2770550
M12SH-1000	2649552	MCCC25-C	2617070	MK46-3D	2634880	MMN5RF-50	2676230	MTA95-C	2770830
M14SH-1000	2649554	MCCC35-C	2617090	MK5/8-15	2599890	MMN5RF-C	2610764	MTA120-C	2771510
M16SH-1000	2649556	MCCC50-C	2617110	MK5	2651575	MMN60-C	2610660	MTA150-C	2771710
M18SH-1000	2649558	MCS4-15	2599868	MK6	2651580	MMN7-C	2610540	MTA185-C	2772150
M20SH-1000	2649560	ME03/2-15	2599875	MK8	2651610	MMN7RF-50	2676240	MTA240-C	2773010
M76SH-1000	2649562	ME1	2652010	MK10	2651640	MMN7RF-C	2610766	MTMA10-GC	2720025
MA03/3-15	2599870	ME1-50	2676005	MK12	2651670	MMN80-3D	2631450	MTMA120-70-GC	2721410
MA1	2650110	ME10	2652130	MK14	2651700	MMN9-C	2610551	MTMA120-95-GC	2721450
MA1-50	2675658	ME10-50	2676060	MK16	2651730	MP608	3031810	MTMA120-GC	2720272
MA10	2650190	ME10-C	2614211	MK18	2651750	MP608/45	3031815	MTMA150-120-GC	2721630
MA10-50	2675666	ME10.24-U	2604830	MK20	2651770	MP608/90	3031820	MTMA150-70-GC	2721550
MA10-C	2610860	ME100-3D	2634940	MK5-50	2675360	MP608D	3031830	MTMA150-95-GC	2721590

Type/Code Cross-Reference chart

Type	Code	Type	Code	Type	Code	Type	Code	Type	Code
MTMA150-GC	2720330	MUT9969-C	2613040	MY30L-50	2677366	PKD106	2808870	PS230-630E	2680189
MTMA16-10-GC	2720560	MUT9970-C	2613041	MY30-C	2613405	PKD108	2808872	PV-1	2591044
MTMA16-GC	2720035	MUT9971-C	2613042	MY3-50	2677315	PKD110	2808874	Q10-4	2167005
MTMA185-120-GC	2721900	MUT9972-C	2613043	MY36-50	2677370	PKD112	2808876	Q10-5	2167010
MTMA185-150-GC	2721910	MUT9973-C	2613044	MY36-C	2613410	PKD1508	2808880	Q10-6	2167015
MTMA185-GC	2720360	MUT9974-C	2613045	MY37-50	2677375	PKD1510	2808882	Q10-8	2167020
MTMA240-GC	2720410	MUT9975-50	2676614	MY37-C	2613415	PKD1512	2808884	Q10-10	2167025
MTMA240-150-GC	2722050	MUT9975-C	2613046	MY3-C	2613355	PKD1518	2808886	Q10-12	2167030
MTMA240-185-GC	2722090	MUT9976-C	2613047	MY4-50	2677320	PKD1612	2808920	Q16-5	2167080
MTMA25-10-GC	2720575	MUT9977-C	2613048	MY48-50	2677380	PKD1618	2808922	Q16-6	2167085
MTMA25-16-GC	2720580	MUT9978-C	2613049	MY48-C	2613420	PKD25016	2808925	Q16-8	2167090
MTMA25-GC	2720090	MUT9979-C	2613050	MY4-C	2613360	PKD25022	2808927	Q16-10	2167095
MTMA300-GC	2720430	MUT9980-50	2676540	MY5-50	2677325	PKD2508	2808890	Q16-12	2167100
MTMA35-20-GC	2720135	MUT9980-C	2613052	MY5-C	2613365	PKD2512	2808892	Q25-5	2167150
MTMA35-GC	2720130	MUT9980-W	2664326	MY60-C	2613425	PKD2518	2808894	Q25-6	2167155
MTMA400-240-GC	2722245	MUT9981-50	2676611	MY6-50	2677330	PKD35016	2808930	Q25-8	2167160
MTMA400-300-GC	2722250	MUT9981-C	2613053	MY6-C	2613370	PKD35025	2808932	Q25-10	2167165
MTMA50-25-GC	2720650	MUT9982-50	2676612	MY7-50	2677335	PKD410	2808900	Q25-12	2167170
MTMA50-35-GC	2720660	MUT9982-C	2613054	MY76-C	2613430	PKD412	2808902	Q25-16	2167175
MTMA50-GC	2720152	MUT9982-W	2664327	MY7-C	2613375	PKD418	2808904	Q35-6	2167230
MTMA500-GC	2720515	MUT9983	2654483	N1-1	2591059	PKD50020	2808935	Q35-8	2167235
MTMA500-300-GC	2722260	MUT9983-50	2676613	N11	2581310	PKD50025	2808937	Q35-10	2167240
MTMA500-400-GC	2722270	MUT9983-C	2613055	N12	2581312	PKD506	2808850	Q35-12	2167245
MTMA70-35-GC	2720940	MUT9983-W	2664328	N13	2581314	PKD508	2808852	Q35-16	2167250
MTMA70-50-GC	2720980	MUT9984-50	2675621	N14	2581316	PKD510	2808854	Q50-6	2167310
MTMA70-GC	2720195	MUT9984-C	2613056	N15	2581318	PKD612	2808910	Q50-8	2167315
MTMA95-50-GC	2721030	MUT9984-W	2664330	N16	2581320	PKD618	2808912	Q50-10	2167320
MTMA95-70-GC	2721070	MUT9985-50	2676495	ND1	2590080	PKD7506	2808860	Q50-12	2167325
MTMA95-GC	2720232	MUT9985-C	2613057	ND2	2590082	PKD7508	2808862	Q50-16	2167330
MTMA16/1	2720031	MUT9985-W	2664335	ND3	2590084	PKD7510	2808864	Q70-6	2167390
MTMA25/1	2720071	MUT9986	2654486	ND4	2590086	PKD7512	2808866	Q70-8	2167395
MTMA35/1	2720111	MUT9986-50	2676616	NIT10	8420017	PKE1012	2809190	Q70-10	2167400
MTMA50/1	2720160	MUT9986-C	2613058	NL03-M	2469328	PKE1018	2809200	Q70-12	2167405
MTMA70/1	2720191	MUT9986-W	2664329	NL03-P	2110870	PKE108	2809090	Q70-16	2167410
MTMA95/1	2720250	MUT9987	2654487	NL06-M	2469330	PKE1508	2809110	Q95-8	2167470
MTMA120/1	2720280	MUT9987-50	2676617	NL06-P	2111950	PKE1510	2809115	Q95-10	2167475
MTMA150/1	2720320	MUT9987-C	2613059	NL06-PB	2111960	PKE1518	2809120	Q95-12	2167480
MTMA185/1	2720370	MUT9987-W	2664332	NL1-M	2469350	PKE1612	2809210	Q95-16	2167485
MTMA240/1	2720400	MUT9988-50	2676618	NL1-P	2113970	PKE1618	2809220	Q120-8	2167540
MTMAD300/1	2720460	MUT9988-C	2613060	NL1-PG	2113990	PKE25016	2809230	Q120-10	2167545
MTMA400/1	2720475	MUT9988-W	2664331	NL2-M	2469390	PKE25022	2809240	Q120-12	2167550
MTMA500-40/1	2720509	MUT9989-50	2676500	NL3-M	2469430	PKE2508	2809130	Q120-16	2167555
MTMA630/1	2720530	MUT9989-W	2664333	NN4-15	2599867	PKE2512	2809135	Q150-10	2167610
MTMAD300-GC	2720440	MUT9990	2654490	NY00	2581322	PKE2518	2809140	Q150-12	2167615
MTMAD300-95-GC	2722121	MUT9990-50	2676620	NY0	2581324	PKE308	2809030	Q150-16	2167620
MTMAD300-150-GC	2722140	MUT9990-C	2613062	NY1	2581326	PKE410	2809152	Q185-10	2167680
MTMAD300-185-GC	2722160	MUT9990-W	2664334	OB2.5P	8420034	PKE412	2809155	Q185-12	2167685
MTMAD300-240-GC	2722220	MUT9991	2654491	PA1	2650230	PKE418	2809160	Q185-16	2167690
MTT16-50	2677220	MUT9991-50	2676590	PA1-50	2675680	PKE508	2809050	Q240-10	2167750
MTT25-50	2677230	MUT9991-C	2613063	PA10	2650290	PKE612	2809170	Q240-12	2167755
MTT35-50	2677240	MUT9991-W	2664336	PA10-50	2675686	PKE618	2809180	Q240-16	2167760
MTT50-50	2677250	MUT9993	2654493	PA10-C	2611010	PKE7508	2809070	Q34-M	6060120
MTT70-50	2677260	MUT9993-50	2676610	PA100-3D	2631930	PKT1014	2809870	Q38-F	6060126
MTT95-50	2677270	MUT9993-C	2613065	PA120-3D	2631950	PKT108	2809790	Q38-MS	6060124
MTT120-50	2677275	MUT9993-W	2664338	PA120-520	2645600	PKT110	2809795	RA-3	2598428
MUA150	2616050	MUT9995	2654495	PA19-50	2675694	PKT1508	2809810	RBG-15	2599850
MUA230-630-400	2680129	MUT9995-50	2676545	PA200-520	2645610	PKT1512	2809820	RBV-15	2599852
MUA230-630-630	2680130	MUT9995-C	2613070	PA24-50	2675696	PKT1614	2809880	RCP-870	2596116
MUA240	2616070	MUT9995-W	2664340	PA24-C	2611020	PKT2510	2809830	RD10055	2685623
MUA300-34	2616090	MUT9996	2654496	PA48-C	2611030	PKT2512	2809840	RD10255	2685636
MUA35	2616010	MUT9996-50	2676546	PA5	2650250	PKT412	2809850	RD11455	2685626
MUA95	2616030	MUT9996-C	2613080	PA5-50	2675682	PKT508	2809760	RD12055	2685624
MUT9914-C	2612995	MUT9996-W	2664342	PA60-C	2611040	PKT510	2809765	RD126X126	2685669
MUT9915-C	2612996	MUT9997	2654497	PB-1	2591046	PKT614	2809860	RD138X138	2685670
MUT9916-C	2612997	MUT9997-50	2676547	PC-1	2590705	PKT7508	2809770	RD14055	2685637
MUT9917-C	2612998	MUT9997-C	2613085	PG-1	2591047	PKT7510	2809775	RD15.555	2685560
MUT9918-C	2612999	MUT9997-W	2664344	PH1-1	2049510	PL01-M	2049510	RD15.555-FC	2685550
MUT9919-C	2613001	MUT9998	2654498	PKC1012	2809490	PL03-M	2051850	RD16.255	2685562
MUT9920-C	2613002	MUT9998-50	2676548	PKC1018	2809500	PL03-P	2051860	RD16.255-FC	2685552
MUT9921-C	2613003	MUT9998-C	2613090	PKC108	2809390	PL06-M	2053850	RD1755	2685563
MUT9922-C	2613004	MUT9998-W	2664346	PKC112	2809400	PL06-P	2053860	RD17.555	2685564
MUT9923-C	2613005	MUT9999	2654499	PKC1508	2809410	PL1-M	2055870	RD17.555-FC	2685554
MUT9924-C	2613006	MUT9999-50	2676550	PKC1510	2809415	PN14-C	2610710	RD18D	2685645
MUT9925-C	2613007	MUT9999-C	2613091	PKC1518	2809420	PN24-C	2610720	RD18.855	2685566
MUT9926-C	2613008	MUT9999-W	2664348	PKC1612	2809510	PN37-C	2610730	RD18.855-FC	2685556
MUT9927-C	2613009	MV150	2616170	PKC1618	2809520	PN48-C	2610740	RD18X46	2685654
MUT9928-C	2613010	MV230-400MC5E	2680860	PKC25016	2809530	PN60-C	2610750	RD19.155	2685568
MUT9929-C	2613011	MV230-630MC6E	2680870	PKC25022	2809540	PN7-C	2610700	RD20.555	2685570
MUT9941-50	2676485	MV240	2616180	PKC2508	2809430	PN80-3D	2631460	RD21.555	2685571
MUT9941-C	2613015	MV35	2616150	PKC2512	2809435	PNB-1	2591040	RD21X21	2685650
MUT9941-W	2664319	MV95	2616160	PKC2518	2809440	PNB-3F/M	2591088	RD22.655	2685572
MUT9942-W	2664320	MVM150	2616310	PKC306	2809320	PNB-3N1	2591092	RD22X30	2685651
MUT9943-W	2664321	MVM230-400MJ5E	2680910	PKC308	2809330	PNB-3N5	2591096	RD22X46	2685656
MUT9943-50	2676490	MVM230-630MJ6E	2680920	PKC35016	2809550	PNB-3NN3	2591094	RD220X220	2685676
MUT9950-C	2613020	MVM240	2616320	PKC35025	2809560	PNB-3NN4	2591095	RD224X224	2685678
MUT9954-50	2676480	MVM35	2616290	PKC410	2809452	PNB-3P	2591090	RD23.855	2685574
MUT9954-W	2664322	MVM95	2616300	PKC412	2809455	PNB-3P1	2591084	RD24D	2685647
MUT9955-C	2613025	MY10-50	2677340	PKC418	2809460	PNB-3PD	2591091	RD25.455	2685576
MUT9956-C	2613026	MY10-C	2613380	PKC50020	2809570	PNB-4KE	2591251	RD2755	2685578
MUT9957-C	2613027	MY14-50	2677345	PKC50025	2809575	PNB-6KE	2591260	RD28.555	2685580
MUT9958-C	2613028	MY14-C	2613385	PKC508	2809350	PNB-6KE-T	2591262	RD28.555-19	2685584
MUT9958-W	2664324	MY16-50	2677350	PKC510	2809360	PNB-7KE	2591268	RD29X71	2685655
MUT9959-C	2613029	MY16-C	2613390	PKC612	2809470	PNB-7KE-T	2591270	RD30.555	2685582
MUT9960-C	2613030	MY19-50	2677355	PKC618	2809480	PO7000	2595904	RD30.555-19	2685586
MUT9961-C	2613032	MY19-C	2613395	PKC70022	2809595	PR-1	2591045	RD31.855	2685588
MUT9962-C	2613033	MY24-50	2677360	PKC7508	2809370	PRCH	2596113	RD32.555	2685590
MUT9964-C	2613034	MY24L-50	2677362	PKC7512	2809380	PS130-150/E	2616371	RD3455	2685591
MUT9965-C	2613036	MY24-C	2613400	PKC95025	2809600	PS130-240/E	2616381	RD34.655	2685592
MUT9966-C	2613037	MY2-50	2677310	PKC120027	2809605	PS130-35/E	2616351	RD35X65	2685675
MUT9967-C	2613038	MY2-C	2613350	PKD1012	2808915	PS130-95/E	2616361	RD36X46	2685658
MUT9968-C	2613039	MY30-50	2677365	PKD1018	2808917	PS230-4005E	2680186	RD37.255	2685594

Type/Code Cross-Reference chart

Type	Code	Type	Code	Type	Code	Type	Code	Type	Code
RD37X104	2685674	RH-FL75	2592597	RP-M7	2046035	S2.5-P12	2163090	SF18X100X1	2852560
RD37X115	2685661	RHM132	2619410	RP-M8	2046040	S2.5-P8	2163010	SF110X100X1	2852570
RD37X54	2685671	RHM50	2670035	RP-P10	2046115	S2.5-PP12	2163170	SF112X100X1	2852580
RD37X67	2685672	RHT160	2592422	RP-P12	2046120	S2.5-PP12/25	2163210	SH-B70	2596080
RD37X88	2685673	RHT160-60N	2592584	RP-P8	2046110	S2.5-PP16/25	2163250	SS4.8-3.7	3041670
RD38.15S	2685596	RHTD270	2682521	RP-PP12	2046140	S2.5-U10	2162730	SS4.8-4.5	3041672
RD38.55S	2685597	RHTD3241	2682502	RP-PP12/1	2046145	S2.5-U12	2162770	SS9-4.5	3041675
RD40.55S	2685598	RHTD410T	2682520	RP-PP12/19	2046150	S2.5-U3	2162410	SS9-5	3041677
RD40.55S-FC	2685627	RHU131-C	2619210	RP-PP12/23	2046155	S2.5-U3.5	2162450	SS9-6.4	3041679
RD41.35S	2685600	RHU230-630	2680075	RP-PP14	2046160	S2.5-U3.5/1	2162460	SUB-D050	8420033
RD41.35S-FC	2685628	RHU450	2640011	RP-PP16/23	2046165	S2.5-U4	2162490	SUB-D075	8420032
RD42.55S	2685602	RHU520	2640151	RP-PPL30	2046180	S2.5-U4/1	2162510	T10-L6	2380280
RD42.55S-FC	2685629	RHU600	2640250	RP-PPL46	2046185	S2.5-U4/2	2162530	T10-L8	2380285
RD43.25S	2685604	RHU1000	2640810	RP-U10	2046265	S2.5-U5	2162570	T10-M10	2380250
RD43.25S-FC	2685630	RHU81	2600045	RP-U12	2046270	S2.5-U6	2162610	T10-M5	2380220
RD44.55S	2685606	RKF-BF4	2051632	RP-U3	2046210	S2.5-U6/1	2162650	T10-M6	2380230
RD44.55S-FC	2685632	RKF-BM4	2051662	RP-U3.5	2046215	S2.5-U8	2162690	T10-M8	2380240
RD46X107	2685652	RKF-F305	2051562	RP-U3.5/2	2046217	S6-M10	2163830	T10-L10	2381105
RD46X46	2685660	RKF-F308	2051582	RP-U4	2046230	S6-M10/1	2163850	T120-L12	2381110
RD46X54	2685662	RKF-F405	2051602	RP-U4/1	2046231	S6-M12	2163890	T120-M10	2381050
RD46X72	2685664	RKF-F405P	2051607	RP-U4/2	2046240	S6-M14	2163930	T120-M12	2381060
RD46X92	2685677	RKF-F408	2051592	RP-U5	2046245	S6-M16	2163970	T120-M14	2381070
RD47.25S	2685608	RKF-F408P	2051597	RP-U5/1	2046246	S6-M3	2163510	T120-M16	2381080
RD47.25S-FC	2685634	RKF-F608	2051612	RP-U6	2046255	S6-M3.5	2163550	T120-M8	2381040
RD48.55S	2685609	RKF-F608P	2051622	RP-U6/1	2046256	S6-M4	2163590	T150-L10	2381305
RD50.55S	2685610	RKF-FM608	2051692	RP-U8	2046260	S6-M5	2163630	T150-L12	2381310
RD50X98	2685663	RKF-M608	2051652	RS0305.07	3008006	S6-M6	2163670	T150-M8	2381240
RD51.45S	2685611	RKY-M3	2145684	RS0407.M12	3008050	S6-M6/1	2163710	T150-M10	2381250
RD52.45S	2685613	RKY-M3.5	2145685	RS0507.09	3008008	S6-M7	2163750	T150-M12	2381260
RD54.25S	2685612	RKY-M3.5/1	2145687	RS0509.M16	3008052	S6-M8	2163790	T150-M14	2381270
RD60SS	2685614	RKY-M4	2145690	RS0710.11	3008010	S6-M8/1	2163800	T150-M16	2381280
RD60.55S	2685615	RKY-M5	2145699	RS0813.M20	3008054	S6-P10	2164710	T16-L6	2380380
RD64SS	2685616	RKY-M6/1	2145705	RS1014.16	3008012	S6-P12	2164750	T16-L8	2380385
RD65SS	2685618	RKY-M8	2145711	RS1117.M25	3008056	S6-P14	2164790	T16-L10	2380390
RD67X126	2685665	RKY-M10	2145715	RS1420.21	3008014	S6-PP12	2164830	T16-M10	2380350
RD68X68	2685666	RKY-M12	2145718	RS1520.M32	3008058	S6-PP17	2164870	T16-M5	2380320
RD72X136	2685667	RKY-P8	2145782	RS1928.M40	3008060	S6-U10	2164370	T16-M6	2380330
RD76SS	2685620	RKY-P10	2145783	RS2026.29	3008016	S6-U10/1	2164390	T16-M8	2380340
RD76.55S	2685619	RKY-P12	2145784	RS2635.36	3008018	S6-U12	2164430	T18S-L10	2381495
RD80.55S	2685622	RKY-PP12	2145790	RS2735.M50	3008062	S6-U14	2164470	T18S-M10	2381450
RD89SS	2685621	RKY-PP12/19	2145792	RT11	2592480	S6-U16	2164510	T18S-M12	2381460
RD90SS	2685625	RKY-PP16/23	2145793	RT10.5	2592470	S6-U3.5	2164170	T18S-M14	2381470
RD92X92	2685668	RKY-PPL30	2145795	RT21	2592550	S6-U4	2164210	T18S-M16	2381480
RF-BF4	2051630	RKY-PPL46	2145798	RT13	2592490	S6-U5	2164250	T240-M10	2381650
RF-BM4	2051660	RKY-U3	2145730	RT13.5	2592495	S6-U6	2164290	T240-M12	2381660
RF-F305	2051560	RKY-U3.5	2145733	RT14	2592500	S6-U8	2164330	T240-M12/31	2381665
RF-F305P	2051565	RKY-U4	2145736	RT15	2592510	SC1	2591261	T240-M14	2381670
RF-F308	2051580	RKY-U5	2145739	RT17	2592530	SC3X	2591264	T240-M16	2381680
RF-F308P	2051585	RKY-U6	2145742	RT6.5	2592430	SC5X	2591266	T240-M20	2381690
RF-F405	2051600	RKY-U6/1	2145743	RT8.5	2592450	SC6X	2591239	T25-L6	2380480
RF-F405P	2051605	RN-FA305	3031610	RT9	2592460	SF13X9X0.8	2850520	T25-L8	2380485
RF-F408	2051590	RN-FA405	3031615	S10-M4	2165130	SF16X9X0.8	2850550	T25-L10	2380470
RF-F408P	2051595	RN-FA608	3031620	S10-M5	2165150	SF12X13X0.5	2850710	T25-M5	2380425
RF-F608	2051610	RN-M10	2150430	S10-M6	2165190	SF13X13X0.5	2850720	T25-M10	2380450
RF-F608P	2051620	RN-M12	2150470	S10-M7	2165230	SF14X13X0.5	2850730	T25-M12	2380460
RF-FM608	2051690	RN-M2	2150010	S1.5-M10	2160390	SF16X13X0.5	2850750	T25-M6	2380430
RF-M10	2050390	RN-M3	2150030	S1.5-M12	2160430	SF13X15.5X0.8	2850920	T25-M8	2380440
RF-M12	2050430	RN-M3.5	2150070	S1.5-M2	2160010	SF14X15.5X0.8	2850930	T300-M10	2381750
RF-M2	2050010	RN-M3.5/1	2150110	S1.5-M3	2160030	SF16X15.5X0.8	2850950	T300-M12	2381760
RF-M3	2050030	RN-M4	2150150	S1.5-M3.5	2160070	SF110X15.5X0.8	2850970	T300-M14	2381770
RF-M3.5	2050070	RN-M4/3	2150170	S1.5-M3.5/1	2160110	SF12X20X1	2851110	T300-M16	2381780
RF-M3.5/1	2050110	RN-M5	2150190	S1.5-M4	2160150	SF13X20X1	2851120	T300-M20	2381790
RF-M4	2050150	RN-M6	2150230	S1.5-M4/3	2160160	SF14X20X1	2851130	T35-L10	2380590
RF-M4/3	2050170	RN-M6/1	2150270	S1.5-M5	2160190	SF15X20X1	2851140	T35-L6	2380580
RF-M5	2050190	RN-M7	2150350	S1.5-M6	2160230	SF16X20X1	2851150	T35-L8	2380585
RF-M6	2050230	RN-M8	2150390	S1.5-M6/1	2160270	SF18X20X1	2851160	T35-M10	2380550
RF-M6/1	2050270	RN-MA305	3031710	S1.5-M7	2160310	SF12X24X1	2851310	T35-M12	2380560
RF-M608	2051650	RN-MA405	3031715	S1.5-M8	2160350	SF13X24X1	2851320	T35-M6	2380530
RF-M608P	2051655	RN-MA608	3031720	S1.5-P10	2161190	SF14X24X1	2851330	T35-M8	2380540
RF-M7	2050310	RN-P10	2151270	S1.5-P12	2161230	SF15X24X1	2851340	T400-M14	2381875
RF-M8	2050350	RN-P12	2151310	S1.5-P8	2161150	SF16X24X1	2851350	T400-M16	2381880
RF-P10	2051250	RN-P8	2151230	S1.5-PP12	2161310	SF18X24X1	2851360	T400-M20	2381890
RF-P12	2051290	RN-PP12	2151350	S1.5-PP12/1	2161330	SF110X24X1	2851370	T4-M4	2380060
RF-P8	2051210	RN-PP12/1	2151370	S1.5-PP12/19	2161350	SF12X32X1	2851510	T4-M5	2380070
RF-PP12	2051330	RN-PP12/19	2151390	S1.5-PP14	2161360	SF13X32X1	2851520	T4-M6	2380080
RF-PP12/1	2051340	RN-PP14	2151400	S1.5-U10	2160950	SF14X32X1	2851530	T50-L6	2380680
RF-PP12/19	2051370	RN-PP16/23	2151410	S1.5-U12	2160990	SF15X32X1	2851540	T50-L8	2380685
RF-PP12/23	2051380	RN-U10	2150990	S1.5-U3	2160630	SF16X32X1	2851550	T50-L10	2380690
RF-PP14	2051410	RN-U12	2151030	S1.5-U3.5	2160670	SF18X32X1	2851560	T50-M10	2380650
RF-PP16/23	2051450	RN-U3	2150670	S1.5-U3.5/2	2160682	SF110X32X1	2851570	T50-M12	2380660
RF-PPL30	2051460	RN-U3.5	2150710	S1.5-U4	2160710	SF14X40X1	2851730	T50-M6	2380630
RF-PPL46	2051465	RN-U3.5/2	2150720	S1.5-U4/1	2160730	SF15X40X1	2851740	T50-M8	2380640
RF-U10	2050950	RN-U4	2150750	S1.5-U4/2	2160750	SF16X40X1	2851750	T6-L6	2380180
RF-U12	2050990	RN-U4/1	2150760	S1.5-U5	2160790	SF18X40X1	2851760	T6-M4	2380110
RF-U3	2050630	RN-U4/2	2150790	S1.5-U5/1	2160800	SF110X40X1	2851770	T6-M5	2380120
RF-U3.5	2050670	RN-U5	2150830	S1.5-U6	2160830	SF14X50X1	2851930	T6-M6	2380130
RF-U3.5/1	2050680	RN-U5/1	2150840	S1.5-U6/1	2160870	SF15X50X1	2851940	T6-M8	2380140
RF-U3.5/2	2050681	RN-U6	2150870	S1.5-U8	2160910	SF16X50X1	2851950	T70-L8	2380785
RF-U4	2050710	RN-U6/1	2150910	S2.5-M10	2162170	SF18X50X1	2851960	T70-L10	2380790
RF-U4/1	2050730	RN-U8	2150950	S2.5-M12	2162210	SF110X50X1	2851970	T70-L12	2380795
RF-U4/2	2050750	RP-M10	2046045	S2.5-M2	2161800	SF15X63X1	2852140	T70-M10	2380750
RF-U5	2050790	RP-M12	2046050	S2.5-M3	2161810	SF16X63X1	2852150	T70-M12	2380760
RF-U5/1	2050791	RP-M2	2046005	S2.5-M3.5	2161850	SF18X63X1	2852160	T70-M8	2380740
RF-U6	2050830	RP-M3	2046010	S2.5-M3.5/1	2161890	SF110X63X1	2852170	T95-L10	2380905
RF-U6/1	2050870	RP-M3.5	2046015	S2.5-M4	2161930	SF14X80X1	2852330	T95-L12	2380910
RF-U8	2050910	RP-M3.5/1	2046016	S2.5-M5	2161970	SF15X80X1	2852340	T95-M10	2380850
RH50	2670050	RP-M4	2046020	S2.5-M6	2162010	SF16X80X1	2852350	T95-M12	2380860
RH61	2670214	RP-M4/3	2046023	S2.5-M6/1	2162050	SF18X80X1	2852360	T95-M14	2380870
RHC131	2619010	RP-M5	2046025	S2.5-M7	2162090	SF110X80X1	2852370	T95-M16	2380880
RHC131LN	2619021	RP-M6	2046030	S2.5-M8	2162130	SF15X100X1	2852540	T95-M8	2380840
RH-FC48N	2592596	RP-M6/1	2046031	S2.5-P10	2163050	SF16X100X1	2852550	TB516X20RE	2811035

Type/Code Cross-Reference chart

Type	Code	Type	Code	Type	Code	Type	Code	Type	Code
TBS24X20RE	2811037	TCS762X25BK	2811340	TD-14X14-M14/1	2685004	TSS95YE	2811808	VAL-P44	2590654
TBS32X10RE	2811039	TCS1016X25BK	2811342	TD-16	2685002	TSS127YE	2811810	VAL-P48	2590655
TBS48X10RE	2811041	TCS1260X25BK	2811344	TD-19	2685008	TSS190YE	2811812	VAL-P51	2590658
TBS64X10RE	2811043	TCS1500X25BK	2811346	TD-20	2685001	TSS254YE	2811814	VAL-P54	2590661
TBS95X10RE	2811045	TCS16X200YE	2811352	TD-20X20-M20	2685014	TSS380YE	2811816	VAL-P56	2590665
TBS127X10RE	2811047	TCS24X200YE	2811354	TD-20X20-M20-C	2685019	TSS510YE	2811818	VAL-P57	2590663
TBS190X5RE	2811049	TCS32X200YE	2811356	TD-27	2685007	TSS12GN	2811827	VAL-P59	2590667
TBS254X5RE	2811051	TCS48X100YE	2811358	TD-28.5	2685009	TSS16GN	2811829	VALSTAR-V3-F	2590577
TBS16X20BK	2811110	TCS64X100YE	2811360	TD-120X20-M20	2685013	TSS24GN	2811831	VALSTAR-ND2/PKC	2590565
TBS24X20BK	2811112	TCS95X100YE	2811362	TD-9	2685003	TSS32GN	2811833	VALSTAR-ND2/PKE	2590567
TBS32X10BK	2811114	TCS127X100YE	2811364	TD-M16C	2685010	TSS48GN	2811835	VALSTAR-ND2/PKD	2590566
TBS48X10BK	2811116	TCS190X100YE	2811366	TF300-Q38F	2592862	TSS64GN	2811837	VALSTAR-R3/IDT	2590593
TBS64X10BK	2811118	TCS254X50YE	2811368	TF300-Q38FM	2592863	TSS95GN	2811839	VALSTAR-V3-F	2590577
TBS95X10BK	2811120	TCS16X200GN	2811390	TF600-Q38FM	2592981	TSS127GN	2811841	VAL-TC055	2593325
TBS127X10BK	2811122	TCS24X200GN	2811392	TGD-10X10-M9	2685018	TSS190GN	2811843	VAL-TC065-5C	2593324
TBS190X5BK	2811124	TCS32X200GN	2811394	TGD-13.5X13.5-M13	2685017	TSS254GN	2811845	VAL-TC085	2593323
TBS254X5BK	2811126	TCS48X100GN	2811396	TGM38	3016155	TSS380GN	2811847	VAL-TC120	2593322
TBS16X20V/G	2811160	TCS64X100GN	2811398	TGM48	3016157	TSS510GN	2811849	VP-M2	2048010
TBS24X20V/G	2811162	TCS95X100GN	2811400	TGM513	3016165	TSS12GY	2811857	VP-M3	2048030
TBS32X10V/G	2811164	TCS127X100GN	2811402	TGM58	3016159	TSS16GY	2811859	VP-M3.5	2048070
TBS48X10V/G	2811166	TCS190X100GN	2811404	TGM613	3016167	TSS24GY	2811861	VP-M4	2048150
TBS64X10V/G	2811168	TCS254X50GN	2811406	TGM713	3016169	TSS32GY	2811863	VP-M5	2048190
TBS95X10V/G	2811170	TCS16X200BU	2811420	TGM817	3016171	TSS48GY	2811865	VP-M6	2048210
TBS127X10V/G	2811172	TCS24X200BU	2811422	TN120S	2590270	TSS64GY	2811867	VP-P10	2049210
TBS190X5V/G	2811174	TCS32X200BU	2811424	TN120SE	2590280	TSS95GY	2811869	VP-PP12/19	2049370
TBS254X5V/G	2811176	TCS48X100BU	2811426	TN70	2590230	TSS127GY	2811871	VP-U3	2048630
TBS16X20BU	2811185	TCS64X100BU	2811428	TN70SE	2590260	TSS190GY	2811873	VP-U3.5	2048670
TBS24X20BU	2811187	TCS95X100BU	2811430	TND6-70	2590120	TSS254GY	2811875	VP-U4	2048710
TBS32X10BU	2811189	TCS127X100BU	2811432	TND10-120	2590145	TSS380GY	2811877	WF6	8420030
TBS48X10BU	2811191	TCS190X100BU	2811434	TNN120	2590290	TSS510GY	2811879	WF16	8420015
TBS64X10BU	2811193	TCS254X50BU	2811436	TNN70	2590240	TSS12BR	2811886	WF35	8420031
TBS95X10BU	2811195	TCS381X50BU	2811438	TNN71	2590241	TSS16BR	2811888	WL03-M	2469780
TBS127X10BU	2811197	TCS32X200TR	2811540	TRD-9.4C	2685015	TSS24BR	2811890	WL06-M	2469785
TBS190X5BU	2811199	TCS64X100TR	2811542	TRD-M11C	2685016	TSS32BR	2811892	WL1-M	2469790
TBS254X5BU	2811201	TCS48X100TR	2811543	TRS-B70	2593280	TSS48BR	2811894	WT2-3D	2636970
TBS16X20WH	2811261	TCS95X100TR	2811544	TSS12BK	2811646	TSS64BR	2811896	Z10-1	2845030
TBS24X20WH	2811263	TCS127X100TR	2811546	TSS16BK	2811648	TSS95BR	2811898	Z16-1	2845040
TBS32X10WH	2811265	TCS160X100TR	2811547	TSS24BK	2811650	TSS127BR	2811900	Z16-12	2844156
TBS48X10WH	2811267	TCS190X100TR	2811548	TSS32BK	2811652	TSS190BR	2811902	Z16-12D	2844157
TBS64X10WH	2811269	TCS12X200TR	2811549	TSS48BK	2811654	TSS254BR	2811904	Z16-3	2844115
TBS95X10WH	2811271	TCS16X200TR	2811551	TSS64BK	2811656	TSS380BR	2811906	Z16-3D	2844116
TBS127X10WH	2811273	TCS24X200TR	2811552	TSS95BK	2811658	TSS510BR	2811908	Z16-4	2844130
TBS190X5WH	2811275	TCS254X50TR	2811553	TSS127BK	2811660	TSS12Y/G	2811914	Z16-4D	2844131
TBS254X5WH	2811277	TCS320X50TR	2811554	TSS190BK	2811662	TSS16Y/G	2811916	Z16-5N	2844122
TBS16X20GY	2811210	TCS381X50TR	2811555	TSS254BK	2811664	TSS24Y/G	2811918	Z16-5ND	2844123
TBS24X20GY	2811212	TCS508X25TR	2811556	TSS380BK	2811666	TSS32Y/G	2811920	Z16-8	2844140
TBS32X10GY	2811214	TCS762X25TR	2811557	TSS510BK	2811668	TSS48Y/G	2811922	Z16-8D	2844141
TBS48X10GY	2811216	TCS1016X25TR	2811558	TSS12RE	2811676	TSS64Y/G	2811924	Z25-1	2845050
TBS64X10GY	2811218	TCS1260X25TR	2811559	TSS16RE	2811678	TSS95Y/G	2811926	Z25-DP7-100	2845180
TBS95X10GY	2811220	TCS1500X25TR	2811560	TSS24RE	2811680	TSS127Y/G	2811928	Z2.5-1	2845010
TBS127X10GY	2811222	TCS16X200RE	2811450	TSS32RE	2811682	TSS190Y/G	2811930	Z35-1	2845060
TBS190X5GY	2811224	TCS24X200RE	2811452	TSS48RE	2811684	TSS254Y/G	2811932	Z35-26D	2844216
TBS254X5GY	2811226	TCS32X200RE	2811454	TSS64RE	2811686	TSS380Y/G	2811934	Z35-3	2844205
TBS16X20BR	2811235	TCS48X100RE	2811456	TSS95RE	2811688	UP130-120	2616520	Z35-3D	2844206
TBS24X20BR	2811237	TCS64X100RE	2811458	TSS127RE	2811690	UP130-150	2616530	Z35-4	2844201
TBS32X10BR	2811239	TCS95X100RE	2811460	TSS190RE	2811692	UP130-185	2616550	Z35-4D	2844202
TBS48X10BR	2811241	TCS127X100RE	2811462	TSS254RE	2811694	UP130-240	2616560	Z35-6	2844210
TBS64X10BR	2811243	TCS190X100RE	2811464	TSS380RE	2811696	UP130-50	2616470	Z35-6D	2844211
TBS95X10BR	2811245	TCS254X50RE	2811466	TSS510RE	2811698	UP130-70	2616490	Z35-DP14-125	2845210
TBS127X10BR	2811247	TCS16X200WH	2811480	TSS12WH	2811706	UP130-95	2616500	Z35-DP14B-125	2845212
TBS190X5BR	2811249	TCS20X200WH	2811481	TSS16WH	2811708	VAL-04	2593310	Z35T-11	2844220
TBS254X5BR	2811251	TCS24X200WH	2811482	TSS24WH	2811710	VAL-096	2593669	Z35T-11D	2844221
TC025	2591895	TCS32X200WH	2811484	TSS32WH	2811712	VAL-1000	2593426	Z50-10D	2844230
TC04N	2591392	TCS48X100WH	2811486	TSS48WH	2811714	VAL-130	2610450	Z50-DP12-160	2845220
TC050	2597050	TCS64X100WH	2811488	TSS64WH	2811716	VAL-130-U	2610451	Z6-1	2845020
TC050Y	2597056	TCS95X100WH	2811490	TSS95WH	2811718	VAL-160	2593405	Z6-10	2844106
TC055	2591860	TCS127X100WH	2811492	TSS127WH	2811720	VAL-22-TC120	2593391	Z6-10D	2844107
TC065-5C	2591870	TCS190X100WH	2811494	TSS190WH	2811722	VAL-231	2593384	Z6-3	2844080
TC085	2597150	TCS254X50WH	2811496	TSS254WH	2811724	VAL-230-630	2680085	Z6-3D	2844081
TC096	2597360	TCS32X200Y/G	2811515	TSS380WH	2811726	VAL-450	2593424	Z6-5	2844100
TC120	2597250	TCS48X100Y/G	2811517	TSS510WH	2811728	VAL-520	2593410	Z6-5D	2844101
TCP10	3019220	TCS64X100Y/G	2811519	TSS12BU	2811736	VAL-600	2593425	Z6-6	2844108
TCP12	3019225	TCS95X100Y/G	2811521	TSS16BU	2811738	VAL-75	2600110	Z6-6D	2844109
TCP15	3019230	TCS127X100Y/G	2811523	TSS24BU	2811740	VAL-B68RC3	2593412	ZKE2	2590710
TCP18	3019235	TCS190X100Y/G	2811525	TSS32BU	2811742	VAL-B-TC950	2593704	ZKE610	2590718
TCP20	3019240	TCS254X50Y/G	2811527	TSS48BU	2811744	VAL-CP096	2593671	ZKE616	2590725
TCP25	3019250	TCS381X50Y/G	2811511	TSS64BU	2811746	VAL-CP096-W	2593674	ZKE6-F	2590716
TCP30	3019260	TCS508X25Y/G	2811513	TSS95BU	2811748	VAL-ECW-H3D	2593421	ZP2	2590760
TCP35	3019270	TCS16X200GY	2811571	TSS127BU	2811750	VAL-FC470	2593710	ZS-B16	2842185
TCP40	3019280	TCS24X200GY	2811573	TSS190BU	2811752	VAL-MAT230-630	2680086	ZS-B4	2842115
TCP45	3019290	TCS32X200GY	2811575	TSS254BU	2811754	VAL-MAT520	2593411	ZS-B6	2842155
TCP5	3019210	TCS48X100GY	2811577	TSS380BU	2811756	VAL-MAT-W	2670076	ZS-T16	2842190
TCP50	3019300	TCS64X100GY	2811579	TSS510BU	2811758	VAL-P1	2590595	ZS-T4	2842120
TCP55	3019305	TCS95X100GY	2811581	TSS12TR	2811766	VAL-P3	2590610	ZS-T6	2842160
TCP60	3019310	TCS127X100GY	2811583	TSS16TR	2811768	VAL-P4	2590612	ZS-U16	2842180
TCP65	3019315	TCS190X100GY	2811585	TSS24TR	2811770	VAL-P5	2590614	ZS-U4	2842110
TCP70	3019320	TCS254X50GY	2811587	TSS32TR	2811772	VAL-P7	2590616	ZS-U6	2842150
TCS12X200BK	2811312	TCS381X50GY	2811589	TSS48TR	2811774	VAL-P10	2590620		
TCS16X200BK	2811314	TCS16X200BR	2811602	TSS64TR	2811776	VAL-P18	2590628		
TCS24X200BK	2811316	TCS24X200BR	2811604	TSS95TR	2811778	VAL-P19	2590629		
TCS32X200BK	2811318	TCS32X200BR	2811606	TSS127TR	2811780	VAL-P21	2874156		
TCS48X100BK	2811320	TCS48X100BR	2811608	TSS190TR	2811782	VAL-P22	2874157		
TCS64X100BK	2811322	TCS64X100BR	2811610	TSS254TR	2811784	VAL-P25	2590633		
TCS95X100BK	2811324	TCS95X100BR	2811612	TSS380TR	2811786	VAL-P26	2590635		
TCS127X100BK	2811326	TCS127X100BR	2811614	TSS510TR	2811788	VAL-P27	2590638		
TCS160X100BK	2811328	TCS190X100BR	2811616	TSS12YE	2811796	VAL-P28	2590639		
TCS190X100BK	2811330	TCS254X50BR	2811618	TSS16YE	2811798	VAL-P29	2590641		
TCS254X50BK	2811332	TCS381X50BR	2811620	TSS24YE	2811800	VAL-P30	2590642		
TCS320X50BK	2811334	TD-10X10-M10	2685011	TSS32YE	2811802	VAL-P38	2590650		
TCS381X50BK	2811336	TD-11	2685005	TSS48YE	2811804	VAL-P39	2590651		
TCS508X25BK	2811338	TD-14X14-M14	2685012	TSS64YE	2811806	VAL-P40	2590652		

Comparison of AWG, MCM and Metric conductor cross sections

CONDUCTORS SECTIONS

Conversion Table AWG, MCM / mm²

[AWG]	Actual conductor csa mm ²	Comparable metric csa mm ²	[MCM]	Actual conductor csa mm ²	Comparable metric csa mm ²
27	0,10		250	127	120
26	0,13	0,14	300	152	150
25	0,16	-	350	177	185
24	0,21	0,2	400	203	-
23	0,26	0,25	500	253	240
22	0,33	0,34	600	304	300
21	0,41	-	700	355	-
20	0,52	0,5	800	405	400
19	0,65	-	900	456	-
18	0,82	0,75	1000	507	500
17	1,04	1	1250	633	625
16	1,31	-	1500	760	800
15	1,65	1,5	1750	887	-
14	2,08	-	2000	1010	1000
13	2,63	2,5			
12	3,31	-			
11	4,15	4			
10	5,27	6			
9	6,62	-			
8	8,35	-			
7	10,6	10			
6	13,3	-			
5	16,8	16			
4	21,2	-			
3	26,7	25			
2	33,6	35			
1	42,4	-			
1/0	53,4	50			
2/0	67,5	70			
3/0	85,0	95			
4/0	107,2	120			

IEC 60228 : 2004 - 11 conductor tables

MAXIMUM DIAMETERS OF CIRCULAR COPPER CONDUCTORS: SOLID, NON COMPACTED STRANDED AND FLEXIBLE

Cross sectional area [mm ²]	Conductors in cables for fixed installations		Flexible conductors (Classes 5 and 6) Maximum diameter [mm]
	Solid (Class 1) Maximum diameter [mm]	Stranded (Class 2) Maximum diameter [mm]	
0,5	0,9	1,1	1,1
0,75	1	1,2	1,3
1	1,2	1,4	1,5
1,5	1,5	1,7	1,8
2,5	1,9	2,2	2,4
4	2,4	2,7	3
6	2,9	3,3	3,9
10	3,7	4,2	5,1
16	4,6	5,3	6,3
25 ^a	5,7	6,6	7,8
35 ^a	6,7	7,9	9,2
50 ^a	7,8	9,1	11
70 ^a	9,4	11	13,1
95 ^a	11	12,9	15,1
120 ^a	12,4	14,5	17
150 ^a	13,8	16,2	19
185	15,4	18	21
240	17,6	20,6	24
300	19,8	23,1	27
400	22,2	26,1	31
500	-	29,2	35
630	-	33,2	39
800	-	37,6	-
1000	-	42,2	-

NOTE: The values given for flexible conductors represent both class 5 and class 6 conductors.

^a Solid copper conductor having cross-sectional areas of 25 mm² and above are for particular types of cable, e.g. mineral insulated, and not for general purposes.

MINIMUM AND MAXIMUM DIAMETERS OF STRANDED COMPACTED CIRCULAR COPPER, ALUMINIUM AND ALUMINIUM ALLOY CONDUCTORS

Cross-sectional area [mm ²]	Stranded compacted circular conductors (Class 2)	
	Minimum diameter [mm]	Maximum diameter [mm]
10	3,6	4,0
16	4,6	5,2
25	5,6	6,5
35	6,6	7,5
50	7,7	8,6
70	9,3	10,2
95	11,0	12,0
120	12,3	13,5
150	13,7	15,0
185	15,3	16,8
240	17,6	19,2
300	19,7	21,6
400	22,3	24,6
500	25,3	27,6
630	28,7	32,5

NOTES: - The dimensional limits of Aluminium conductors with cross-sectional areas above 630 mm² are not given as the compaction technology is not generally established.

- The values are given for compacted copper conductors in the size range 1,5 mm² to 6 mm².

MINIMUM AND MAXIMUM DIAMETERS OF CIRCULAR ALUMINIUM CONDUCTORS

Cross-sectional area [mm ²]	Solid conductors (Class 1)	
	Minimum diameter [mm]	Maximum diameter [mm]
10	3,4	3,7
16	4,1	4,6
25	5,2	5,7
35	6,1	6,7
50	7,2	7,8
70	8,7	9,4
95	10,3	11,0
120	11,6	12,4
150	12,9	13,8
185	14,5	15,4
240	16,7	17,6
300	18,8	19,8
400	21,2	22,2
500	24,0	25,1
630	27,3	28,4
800	30,9	32,1
1000	34,8	36,0
1200	37,8	39,0

IEC 60228 : 2004 - 11 conductor tables

CLASS 1:

SOLID CONDUCTORS FOR SINGLE-CORE AND MULTI-CORE CABLES

Nominal cross-sectional area [mm ²]	Maximum resistance of conductor at 20 °C		
	Circular, annealed Copper conductors		Aluminium and Aluminium alloy conductors, circular or shaped c [ohm/km]
	Plain [ohm/km]	Metal [ohm/km]	
0,5	36	36,7	-
0,75	24,5	24,8	-
1	18,1	18,2	-
1,5	12,1	12,2	-
2,5	7,41	7,56	-
4	4,61	4,70	-
6	3,08	3,11	-
10	1,83	1,84	3,08 ^a
16	1,15	1,16	1,91 ^a
25	0,727 ^b	-	1,20 ^a
35	0,524 ^b	-	0,868 ^a
50	0,387 ^b	-	0,641
70	0,268 ^b	-	0,443
95	0,193 ^b	-	0,320 ^d
120	0,153 ^b	-	0,253 ^d
150	0,124 ^b	-	0,206 ^d
185	0,101 ^b	-	0,164 ^d
240	0,0775 ^b	-	0,125 ^d
300	0,0620 ^b	-	0,100 ^d
400	0,0465 ^b	-	0,0778
500	-	-	0,0605
630	-	-	0,0469
800	-	-	0,0367
1000	-	-	0,0291
1200	-	-	0,0247

^a Aluminium conductors 10 mm² to 35 mm² circular only

^b Solid Copper conductors having nominal cross-sectional area of 25 mm² and above are for particular types of cable, e.g. mineral insulated, and not for general purposes.

^c For solid Aluminium alloy conductors, having the same nominal cross-sectional area as an Aluminium conductor, the resistance value given in the table should be multiplied by a factor of 1,162 unless otherwise agreed between the manufacturer and the purchaser.

^d For single core cables, four sectoral shaped conductors may be assembled into a single circular conductor. The maximum resistance of the assembled conductor shall be 25% of that of the individual component conductors.

CLASS 2:

STRANDED CONDUCTORS FOR SINGLE-CORE AND MULTI-CORE CABLES

Nominal cross-sectional area [mm ²]	Minimum number of wires in the conductor						Maximum resistance of conductor at 20 °C		
	Circular		Circular compacted		Shaped		Annealed copper conductor		Aluminium or aluminium alloy conductor ^c [ohm/km]
	Cu	Al	Cu	Al	Cu	Al	Plain wires [ohm/km]	Metal-coated wires [ohm/km]	
0,5	7	-	-	-	-	-	36,0	36,7	-
0,75	7	-	-	-	-	-	24,5	24,8	-
1,0	7	-	-	-	-	-	18,1	18,2	-
1,5	7	-	6	-	-	-	12,1	12,2	-
2,5	7	-	6	-	-	-	7,41	7,56	-
4	7	-	6	-	-	-	4,61	4,70	-
6	7	-	6	-	-	-	3,08	3,11	-
10	7	7	6	6	-	-	1,83	1,84	3,08
16	7	7	6	6	-	-	1,15	1,16	1,91
25	7	7	6	6	6	6	0,727	0,734	1,20
35	7	7	6	6	6	6	0,524	0,529	0,868
50	19	19	6	6	6	6	0,387	0,391	0,641
70	19	19	12	12	12	12	0,268	0,270	0,443
95	19	19	15	15	15	15	0,193	0,195	0,320
120	37	37	18	15	18	15	0,153	0,154	0,253
150	37	37	18	15	18	15	0,124	0,126	0,206
185	37	37	30	30	30	30	0,0991	0,100	0,164
240	61	61	34	30	34	30	0,0754	0,0762	0,125
300	61	61	34	30	34	30	0,0601	0,0607	0,100
400	61	61	53	53	53	53	0,0470	0,0475	0,0778
500	61	61	53	53	53	53	0,0366	0,0369	0,0605
630	91	91	53	53	53	53	0,0283	0,0286	0,0469
800	91	91	53	53	-	-	0,0221	0,0224	0,0367
1000	91	91	53	53	-	-	0,0176	0,0177	0,0291
1200							0,0151	0,0151	0,0247
1400 ^a							0,0129	0,0129	0,0212
1600							0,0113	0,0113	0,0186
1800 ^a							0,0101	0,0101	0,0165
2000							0,0090	0,0090	0,0149
2500							0,0072	0,0072	0,0127

^a Non-preferred sizes. Other non-preferred sizes are recognized for some specialized applications but are not within the scope of this standard.

^b The minimum number of wires for these sizes is not specified. These sizes may be constructed from 4, 5 or 6 equal segments (Milliken).

^c For stranded Aluminium alloy conductors having the same nominal cross-sectional area as an Aluminium conductor the resistance value should be agreed between the manufacturer and the purchaser.

IEC 60228 : 2004 - 11 conductor tables

CLASS 5:

FLEXIBLE COPPER CONDUCTORS FOR SINGLE-CORE AND MULTI-CORE CABLES

Nominal cross-sectional [mm ²]	Maximum diameter of wires in conductor [mm]	Maximum resistance of conductor at 20 °C	
		Plain wires [ohm/km]	Metal-coated wires [ohm/km]
0,5	0,21	39	40,1
0,75	0,21	26	26,7
1	0,21	19,5	20
1,5	0,26	13,3	13,7
2,5	0,26	7,98	8,21
4	0,31	4,95	5,09
6	0,31	3,3	3,39
10	0,41	1,91	1,95
16	0,41	1,21	1,24
25	0,41	0,78	0,795
35	0,41	0,554	0,565
50	0,41	0,386	0,393
70	0,51	0,272	0,277
95	0,51	0,206	0,21
120	0,51	0,161	0,164
150	0,51	0,129	0,132
185	0,51	0,106	0,108
240	0,51	0,080	0,081
300	0,51	0,064	0,065
400	0,51	0,048	0,049
500	0,61	0,038	0,039
630	0,61	0,028	0,029

CLASS 6:

FLEXIBLE COPPER CONDUCTORS FOR SINGLE-CORE AND MULTI-CORE CABLES

Nominal cross-sectional [mm ²]	Maximum diameter of wires in conductor [mm]	Maximum resistance of conductor at 20 °C	
		Plain wires [ohm/km]	Metal-coated wires [ohm/km]
0,5	0,16	39	40,1
0,75	0,16	26	26,7
1	0,16	19,5	20
1,5	0,16	13,3	13,7
2,5	0,16	7,98	8,21
4	0,16	4,95	5,09
6	0,21	3,3	3,39
10	0,21	1,91	1,95
16	0,21	1,21	1,24
25	0,21	0,78	0,795
35	0,21	0,554	0,565
50	0,31	0,386	0,393
70	0,31	0,272	0,277
95	0,31	0,206	0,21
120	0,31	0,161	0,164
150	0,31	0,129	0,132
185	0,41	0,106	0,108
240	0,41	0,080	0,081
300	0,41	0,064	0,065

System of denomination of harmonised cables according to CENELEC HD 361

- H** Cable conforming to harmonised standards
- A** Recognised national type of cable
- N** Other type of national cable

- 00** Less than 100 / 100 V
- 01** Above 100 / 100 V and less than 300 / 300 V
- 03** 300 / 300 V
- 05** 300 / 500 V
- 07** 450 / 750 V
- 1** 0,6 / 1 kV

- B** Ethylenpropylene rubber for working temperature of 60° C
- N** Polychloroprene
- N2** Polychloroprene for welding cables
- Q** Polyurethane
- R** Rubber
- V** Common-quality PVC
- V2** PVC for working temperatures of 90° C
- V3** PVC for low temperature cables
- V4** Reticulate PVC
- V5** Oil-resistant PVC
- Z** Polyolefin mixture

- C** Concentric Copper core
- C4** Copper braid screen on multiple cores
- C5** Copper braid screen on single cores
- C7** Screen made of Copper straps or ribbons

- Z2** Round Steel strand armour
- Z3** Steel strap armour
- Z4** Steel ribbon armour
- Z5** Steel strand braid

- H** Flat divisible cable with or without sheath
- H2** Flat indivisible cable
- H3** Flat cable with cores separated by a slat
- H6** Flat cable with three or more cores
- H7** Cable with double-layered insulation
- H8** Extendable cord

- D** Flexible core for weldings cables
- E** Very flexible core for welding cables
- F** Flexible core for moving connections
- H** Very flexible core for moving connections
- K** Flexible core for fixed laying
- R** Rigid round cord
- U** Round rigid single strand

REFERENCE TO THE STANDARDS

RATED VOLTAGE

INSULATION AND SHEATH MATERIAL

SCREENS

ARMOURS

CONSTRUCTIVE FORM OF THE CABLE

CONDUCTOR FLEXIBILITY DEGREE

UL and VDE marking of cable glands

MAXIblock® *spiralblock*®

Type (*)	Thread	COMPRESSION RANGE Ø (min-max)				IMPACT CATEGORY (*)	MARKING
		Nominal [mm]	UL 514B		EN 62444 [mm]		
			[mm]	[inches]			
1900.M12	M12x1,5	3,5-7	4,5	0.18	3,5-7	1	USR-CNR / VDE
1900.M16	M16x1,5	5-10	7	0.28	7-10	1	USR-CNR / VDE
1900.M20	M20x1,5	7-13	13	0.51	8-13	3	USL-CNL / VDE
1900.M25	M25x1,5	10-17	17	0.67	10-17	3	USL-CNL / VDE
1900.M32	M32x1,5	13-21	15-21	0.60-0.83	15-21	3	USL-CNL / VDE
1900.M40	M40x1,5	19-28	21-28	0.83-1.10	19-28	3	USL-CNL / VDE
1900.M50	M50x1,5	27-35	27-34	1.06-1.34	27-35	3	USL-CNL / VDE
1900.M63	M63x1,5	34-45	35-45	1.38-1.77	34-45	3	USL-CNL / VDE
1910.M12	M12x1,5	2-5	3-5	0.12-0.20	2-5	1	USR-CNR / VDE
1910.M16	M16x1,5	3-7	5-7	0.20-0.28	5-7	1	USR-CNR / VDE
1910.M20	M20x1,5	5-10	5-10	0.20-0.40	6-10	3	USR-CNR / VDE
1910.M25	M25x1,5	7-13	7-13	0.28-0.51	7-13	3	USR-CNR / VDE
1910.M32	M32x1,5	8-14	8-14	0.31-0.55	8-14	3	USR-CNR / VDE
1910.M40	M40x1,5	15-23	17-23	0.67-0.91	15-23	3	USL-CNL / VDE
1910.M50	M50x1,5	20-29	21-29	0.83-1.14	21-29	3	USL-CNL / VDE
1910.M63	M63x1,5	27-39	28-39	1.1-1.54	28-39	3	USL-CNL / VDE
1901.M12	M12x1,5	3,5-7	4,5	0.18	3,5-7	1	USR-CNR / VDE
1901.M16	M16x1,5	5-10	7	0.28	5-10	1	USR-CNR / VDE
1901.M20	M20x1,5	7-13	13	0.51	8-13	3	USL-CNL / VDE
1901.M25	M25x1,5	10-17	17	0.67	10-17	3	USL-CNL / VDE
1901.M32	M32x1,5	13-21	15-21	0.60-0.83	15-21	3	USL-CNL / VDE
1901.M40	M40x1,5	19-28	21-28	0.83-1.10	19-28	3	USL-CNL / VDE
1901.M50	M50x1,5	27-35	27-34	1.06-1.34	27-35	3	USL-CNL / VDE
1901.M63	M63x1,5	34-45	35-45	1.38-1.77	34-45	3	USL-CNL / VDE
1500.M12	M12x1,5	3,5-7	4,5	0.18	3,5-7	1	USR-CNR / VDE
1500.M16	M16x1,5	5-10	7	0.28	7-10	1	USR-CNR / VDE
1500.M20	M20x1,5	7-13	13	0.51	8-13	3	USL-CNL / VDE
1500.M25	M25x1,5	10-17	17	0.67	10-17	3	USL-CNL / VDE
1500.M32	M32x1,5	13-21	15-21	0.60-0.83	15-21	3	USL-CNL / VDE

MAXIbrass®

Type	Thread	COMPRESSION RANGE Ø (min-max)				MARKING	
		Nominal [mm]	UL 514B		EN 62444 [mm]		
			[mm]	[inches]			
2900.07N	Pg 7	3-7	3-7	0.12-0.28	3-7	5	USR-CNR
2900.09N	Pg 9	4-8	4-8	0.16-0.31	4-8	6	USR-CNR
2900.11N	Pg 11	4,5-10	6-10	0.24-0.39	6-10	6	USR-CNR
2900.13N	Pg 13,5	5-12	10-12	0.39-0.47	10-12	6	USL-CNL
2900.16N	Pg 16	7-13	10-13	0.39-0.51	10-13	6	USL-CNL
2900.21N	Pg 21	10-17	12-17	0.47-0.67	12-17	6	USL-CNL
2900.29N	Pg 29	17-25	18-25	0.71-0.98	18-25	6	USL-CNL
2900.36N	Pg 36	20-32	23-32	0.91-1.26	23-32	6	USL-CNL
2900.42N	Pg 42	28-38	28-35	1.10-1.38	28-35	6	USL-CNL
2900.48N	Pg 48	34-45	34-45	1.33-1.77	34-45	6	USL-CNL
2910.07N	Pg 7	1-5	2-5	0.08-0.20	2-5	5	USR-CNR
2910.09N	Pg 9	2-6	3-6	0.12-0.24	3-6	5	USR-CNR
2910.11N	Pg 11	2,5-7	3,5-7	0.14-0.28	3,5-7	5	USR-CNR
2910.13N	Pg 13,5	4-10	5,5-10	0.22-0.39	5,5-10	6	USL-CNL
2910.16N	Pg 16	5-10	6-10	0.24-0.39	6-10	6	USL-CNL
2910.21N	Pg 21	6-13	7-13	0.28-0.51	7-13	6	USL-CNL
2910.29N	Pg 29	11-20	12-20	0.47-0.79	12-20	6	USL-CNL
2910.36N	Pg 36	18-26	19-26	0.75-1.02	19-26	6	USL-CNL
2910.42N	Pg 42	24-31	24-31	0.94-1.22	24-31	6	USL-CNL
2910.48N	Pg 48	27-39	31-39	1.22-1.54	31-39	6	USL-CNL
2901.07N	Pg 7	3-7	3-7	0.12-0.28	3-7	5	USR-CNR / VDE
2901.09N	Pg 9	4-8	4-8	0.16-0.31	4-8	6	USR-CNR / VDE
2901.11N	Pg 11	4,5-10	6-10	0.24-0.39	6-10	6	USR-CNR / VDE
2901.13N	Pg 13,5	5-12	10-12	0.39-0.47	10-12	6	USL-CNL / VDE
2901.16N	Pg 16	7-13	10-13	0.39-0.51	10-13	6	USL-CNL / VDE
2901.21N	Pg 21	10-17	12-17	0.47-0.67	12-17	6	USL-CNL / VDE
2901.29N	Pg 29	17-25	18-25	0.71-0.98	18-25	6	USL-CNL / VDE
2901.36N	Pg 36	20-32	23-32	0.91-1.26	23-32	6	USL-CNL / VDE
2901.42N	Pg 42	28-38	28-35	1.10-1.38	28-35	6	USL-CNL / VDE
2911.07N	Pg 7	1-5	2-5	0.08-0.20	2-5	5	USR-CNR
2911.09N	Pg 9	2-6	3-8	0.12-0.31	3-8	5	USR-CNR
2911.11N	Pg 11	2,5-7	3,5-7	0.14-0.28	3,5-7	5	USR-CNR
2911.13N	Pg 13,5	4-10	5,5-10	0.22-0.39	5,5-10	6	USL-CNL
2911.16N	Pg 16	5-10	6-10	0.24-0.39	6-10	6	USL-CNL
2911.21N	Pg 21	6-13	7-13	0.28-0.51	7-13	6	USL-CNL
2911.29N	Pg 29	11-20	12-20	0.47-0.79	12-20	6	USL-CNL
2911.36N	Pg 36	18-26	19-26	0.75-1.02	19-26	6	USL-CNL
2911.42N	Pg 42	24-31	24-31	0.94-1.22	24-31	6	USL-CNL

VDE: Licence nos 40008472, 40008474, 40008475 and 40008476

USL-CNL: UL LISTING file no E220310; control no 485B valid in USA & Canada

USR-CNR: UL RECOGNITION file no E220310 valid in USA & Canada (with reduced tightening force)

MAXIblock® *spiralblock*®

Type (*)	Thread	COMPRESSION RANGE Ø (min-max)				MARKING	
		Nominal [mm]	UL 514B		EN 62444 [mm]		
			[mm]	[inches]			
1900.07	Pg 7	3,5-7	4,5-6,5	0.18-0.25	3,5-7	1	USR-CNR
1900.09	Pg 9	5-8	6-8	0.24-0.31	5-8	1	USR-CNR
1900.11	Pg 11	5-10	6,5-9,5	0.26-0.37	6-10	3	USR-CNR
1900.13	Pg 13,5	7-12	8-11,5	0.31-0.45	7-12	3	USL-CNL
1900.16	Pg 16	10-14	10,5-14	0.41-0.55	10-14	3	USL-CNL
1900.21	Pg 21	13-18	13-18	0.51-0.71	13-18	3	USL-CNL
1900.29	Pg 29	18-25	22-25	0.67-0.98	18-25	3	USL-CNL
1900.36	Pg 36	20-32	21,5-32	0.85-1.26	20-32	3	USL-CNL
1900.42	Pg 42	28-38	32-38	1.26-1.49	28-38	3	USL-CNL
1900.48	Pg 48	34-45	40-44	1.57-1.73	34-45	3	USL-CNL
1910.07	Pg 7	2-5	3-5	0.12-0.20	2-5	1	USR-CNR
1910.11	Pg 11	4-7	4-7	0.16-0.28	4-7	1	USR-CNR
1910.13	Pg 13	5-10	10	0.39	5-10	3	USR-CNR
1910.21	Pg 21	9-15	10-14	0.39-0.55	9-15	3	USR-CNR
1910.36	Pg 36	18-26	18-26	0.71-1.02	18-26	3	USR-CNR
1910.42	Pg 42	25-31	25-31	0.98-1.22	25-31	3	USL-CNL
1901.07	Pg 7	3,5-7	6,5	0.26	3,5-7	1	USR-CNR
1901.09	Pg 9	5-8	6-8	0.24-0.31	5-8	1	USR-CNR
1901.11	Pg 11	5-10	6,5-9,5	0.26-0.37	6-10	3	USR-CNR
1901.13	Pg 13,5	7-12	8-11,5	0.31-0.45	7-12	3	USL-CNL
1901.16	Pg 16	10-14	10,5-14	0.41-0.55	10-14	3	USL-CNL
1901.21	Pg 21	13-18	13-18	0.51-0.71	13-18	3	USL-CNL
1901.29	Pg 29	18-25	22-25	0.67-0.98	18-25	3	USL-CNL
1901.36	Pg 36	20-32	21,5-32	0.85-1.26	20-32	3	USL-CNL
1901.42	Pg 42	28-38	32-38	1.26-1.48	28-38	3	USL-CNL
1901.48	Pg 48	34-45	40-44	1.57-1.73	34-45	3	USL-CNL
1500.07	Pg 7	3,5-7	4,5-6,5	0.18-0.25	3,5-7	1	USR-CNR
1500.09	Pg 9	5-8	6-8	0.24-0.31	5-8	1	USR-CNR
1500.11	Pg 11	5-10	6,5-9,5	0.26-0.37	6-10	3	USR-CNR
1500.13	Pg 13,5	7-12	8-11,5	0.31-0.45	7-12	3	USL-CNL
1500.16	Pg 16	10-14	10,5-14	0.41-0.55	10-14	3	USL-CNL
1500.21	Pg 21	13-18	13-18	0.51-0.71	13-18	3	USL-CNL
1900.14	G1/4"	3-6,5	4,5-6,5	0.18-0.25	3-6,5	1	USR-CNR
1900.38	G3/8"	4-8	6-8	0.24-0.31	4-8	1	USR-CNR
1900.12	G1/2"	7-12	8-11,5	0.31-0.45	7-12	3	USL-CNL
1900.34	G3/4"	13-18	13-18	0.51-0.71	13-18	3	USL-CNL
1901.12	G1/2"	7-12	8-11,5	0.31-0.45	7-12	3	USL-CNL
1500.14	G1/4"	3-6,5	4,5-6,5	0.18-0.25	3-6,5	1	USR-CNR
1500.38	G3/8"	4-8	6-8	0.24-0.31	4-8	1	USR-CNR
1500.12	G1/2"	7-12	8-11,5	0.31-0.45	7-12	3	USL-CNL
1500.34	G3/4"	13-18	13-18	0.51-0.71	13-18	3	USL-CNL

MAXIbrass®

Type	Thread	COMPRESSION RANGE Ø (min-max)				IMPACT CATEGORY (*)	MARKING
		Nominal [mm]	UL 514B		EN 62444 [mm]		
			[mm]	[inches]			
2900.M12N	M12x1,5	3-7	3-7	0.12-0.28	3-7	5	USR-CNR / VDE
2900.M16N	M16x1,5	4,5-10	6-10	0.24-0.39	4,5-10	6	USR-CNR / VDE
2900.M20N	M20x1,5	7-13	8-13	0.31-0.51	7-13	6	USL-CNL / VDE
2900.M25N	M25x1,5	10-17	13-17	0.51-0.67	11-17	6	USL-CNL / VDE
2900.M32N	M32x1,5	11-21	13-21	0.51-0.83	13-21	6	USL-CNL / VDE
2900.M40N	M40x1,5	19-28	21-28	0.83-1.10	19-28	6	USL-CNL / VDE
2900.M50N	M50x1,5	26-35	27-35	1.06-1.38	26-35	6	USL-CNL / VDE
2900.M63N	M63x1,5	34-45	34-45	1.33-1.77	34-45	6	USL-CNL / VDE
2910.M12N	M12x1,5	1-5	2-5	0.08-0.20	2-5	5	USR-CNR / VDE
2910.M16N	M16x1,5	2,5-7	3,5-7	0.14-0.28	4-7	6	USR-CNR / VDE
2910.M20N	M20x1,5	5-10	5-10	0.20-0.39	5,5-10	6	USR-CNR / VDE
2910.M25N	M25x1,5	6-13	8-13	0.31-0.51	6-13	6	USR-CNR / VDE
2910.M32N	M32x1,5	7-14	7-14	0.28-0.55	9-14	6	USR-CNR / VDE
2910.M40N	M40x1,5	13-23	15-23	0.59-0.90	17-23	6	USL-CNL / VDE
2910.M50N	M50x1,5	20-29	20-29	0.79-1.14	25-29	6	USL-CNL / VDE
2910.M63N	M63x1,5	27-39	28-39	1.10-1.54	31-39	6	USL-CNL / VDE
2901.M12N	M12x1,5	3-7	3-7	0.12-0.28	3-7	5	USR-CNR / VDE
2901.M16N	M16x1,5	4,5-10	6-10	0.24-0.39	4,5-10	6	USR-CNR / VDE
2901.M20N	M20x1,5	7-13	8-13	0.31-0.51	7-13	6	USL-CNL / VDE
2901.M25N	M25x1,5	10-17	13-17	0.51-0.67	11-17	6	USL-CNL / VDE
2901.M32N	M32x1,5	11-21	13-21	0.51-0.83	13-21	6	USL-CNL / VDE
2901.M40N	M40x1,5	19-28	21-28	0.83-1.10	19-28	6	USL-CNL / VDE
2901.M50N	M50x1,5	26-35	27-35	1.06-1.38	26-35	6	

Ingress protection (IP) rating according to EN 60529 - CEI 70-1

IP CODE

The first digit (0-6 or X letter):
Protection against ingress of solid matter

Second digit (0-8 or X letter):
Protection against ingress of liquids

(A, B, C, D) for future use.
Restricted entry to dangerous parts:

(H,M,S,W) for future use. Specific criteria:

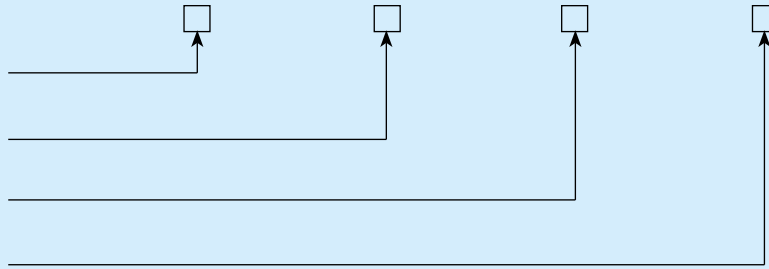

1st CHARACTERISTIC NUMBER:

PROTECTION AGAINST INGRESS OF SOLID MATTER

PROTECTION	0	1	2	3	4	5	6
Protection against ingress of solid matter caused by		solid bodies measuring over 50 mm	solid bodies measuring over 12,5 mm	solid bodies measuring over 2,5 mm	solid bodies measuring over 1 mm	powder in harmful quantities	Powder (completely protected)
Test method		 Diam. 50 mm Accessibility gauge ø 50 mm	 Diam. 12,5 mm Test finger Accessibility gauge ø 12,5 mm	 Diam. 2,5 mm Accessibility gauge ø 2,5 mm	 Diam. 1 mm Accessibility gauge ø 1 mm	 talcum powder	 talcum powder

2nd CHARACTERISTIC NUMBER:

PROTECTION AGAINST INGRESS OF LIQUIDS

PROTECTION	0	1	2	3	4	5	6	7	8
Protection against ingress of liquids caused by		Drops of water falling vertically	Vertical drops of water with inclination of casing up to 15°	Rain	Sprays of water	Jets of water	Powerful jets of water	Temporary Immersion	Permanent Immersion
Test method		 Drops of water falling vertically	 Vertical drops of water with inclination of casing up to 15°	 Rain	 Sprays of water	 Jets of water	 Powerful jets of water	 Temporary Immersion	 Permanent Immersion

1st ADDITIONAL LETTER:

RESTRICTED ENTRY TO DANGEROUS PARTS

RESTRICTED ENTRY	A	B	C	D
Restricted entry to dangerous parts caused by	back of hand	finger	tool	wire
Test method	 accessibility gauge ø 50 mm	 articulated test finger	 accessibility gauge ø 2,5 mm	 accessibility gauge ø 1 mm

2nd ADDITIONAL LETTER:

MEANING OF THE SECOND ADDITIONAL LETTER

SPECIFIC CRITERIA	H	M	S	W
Specific criteria	High voltage equipment	Tested against negative effects of water penetration, when the moveable parts of the equipment (e.g. wheels of a revolving machine) are moving	Tested against the negative effects of water penetration, when the moveable parts of the equipment (e.g. wheels of a revolving machine) are stationary	Suitable for use in environmental conditions as specified and equipped with additional measures of protection

Flammability test for products and materials

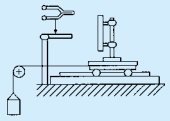
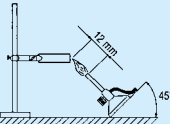
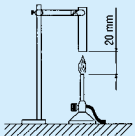
TYPE OF TEST	TEST EQUIPMENT	COMPLIANCE WITH STANDARDS	OBJECTIVE OF TEST	TEST RESULTS	TEST CONDITIONS		
					heat source	length of test	characteristic features
CHARACTERISTIC FEATURES		IEC 695-2-1 CEI 50-11 DIN VDE 0471-2-1	Check that abnormal heating produced by overcurrent and bad contacts does not compromise the safety of the insulating material. Lighting test. The wire is pressed against the sample using force and penetrates up to 7 mm.	Any sign of flame starting must stop within 30 sec. of removing the glowing wire. TEST TEMPERATURE • 650° for materials which do not support parts under tension • 750° for materials which support parts under tension of moving sockets and plugs • 850° for materials which support parts under tension of fixed sockets and switches	Glow-wire 4 mm in diameter	Wire applied for 30 seconds	Flame extinction time
NEEDLE FLAME		IEC 695-2-1 CEI 50-11	Simulates the effect small flames have which may occur due to internal faults of products in order to judge the fire risk.	• the sample does not catch fire • the flame and incandescent particles do not spread the fire • combustion lasts less than 30 seconds	Bunsen burner flame	Flame applied for (Ta) 5, 10, 20, 30, 60, 120 sec. According to particular standards	The degree of severity: flame application time (Ta)
UL (UNDERWRITER LABORATORIES)		UL 94	Measuring of time the sample continues to burn after the direct flame has been removed.	• V0 if the sample burns for less than 5 sec. before going out. • V1 if it burns for less than 25 sec. • V2 if it burns for less than 25 sec. With incandescent drops • HB if it burns for more than 25 sec. (horizontal sample and burning speed less than 38 mm per minute) Comparable to ASTM D-635	Bunsen burner flame	Flame applied for 10 seconds twice following	Length of combustion

Recommended torque settings for cable glands

MAXIblock[®], spiralblock[®], MAXIbrass[®], MAXIinox
METRIC THREADS, TO OBTAIN IP68 INGRESS PROTECTION IN ACCORDANCE WITH EN 50262

Torque values apply to mounting in a threaded entry and to use with a locknut	THREAD CABLE GLAND	CABLE GLAND	
		metallic	non-metallic
		torque (Nm)	
	M12 x 1,5	6.0	2.7
	M16 x 1,5	6.0	5.0
	M20 x 1,5	8.0	7.0
	M25 x 1,5	8.0	7.5
	M32 x 1,5	18.0	8.0
	M40 x 1,5	18.0	8.0
	M50 x 1,5	18.0	15.0
	M63 x 1,5	25.0	15.0

MAXIblock[®], spiralblock[®], MAXIbrass[®], MAXIinox
PG THREADS, TO OBTAIN IP68 INGRESS PROTECTION IN ACCORDANCE WITH DIN VDE

Torque values apply to mounting in a threaded entry and to use with a locknut	THREAD CABLE GLAND	CABLE GLAND	
		metallic	non-metallic
		torque (Nm)	
	Pg7	6.25	2.5
	Pg9	6.25	3.75
	Pg11	6.25	3.75
	Pg13,5	7.5	5.0
	Pg16	7.5	5.0
	Pg21	10.0	7.5
	Pg29	15.0	8.0
	Pg36	25.0	10.0
	Pg42	25.0	10.0
	Pg48	25.0	15.0

MAXIblock[®], spiralblock[®]
GAS THREADS, TO OBTAIN IP68 WITH REDUCED TIGHTENING FORCE

Torque values apply to mounting in a threaded entry and to use with a locknut	THREAD CABLE GLAND	NON-METALLIC CABLE GLAND	
		torque (Nm)	
			G1/4"
	G3/8"	5	
	G1/2"	6	
	G3/4"	10	

Cable glands installation:

- 1) Before proceeding with the installation, inspect the cable gland; installation must be performed by qualified personnel and with suitable tools.
- 2) Cable glands must be used in their original supplied condition with no modifications.
- 3) Torque values listed in the catalogue are intended as the recommended level for reaching the correct IP protection level and achieving the required cable retention properties. As the torque depends on the type of insulation of the conductor used, it is responsibility of the user to define the ideal torque for their specific application.
- 4) Both the body and head of the cable gland must be correctly tightened; excessive or reduced tightening may compromise the protection level and the cable retention performance.
- 5) Loosening a cable gland already installed and then tightening again may result in a reduction of the IP protection level achieved and compromise the cable retention properties. In these instances, we recommend replacement of the cable gland.

New Hand Tool Range

professional

Cembre offers a range of tool holders designed to provide professional users with practical and neat ways to optimise their time and working conditions.



Ask for the specific catalog



Also available in the Cembre product range

"Industrial Marking Systems"



PC-DRIVEN THERMAL TRANSFER MARKER
PRINTING SYSTEM

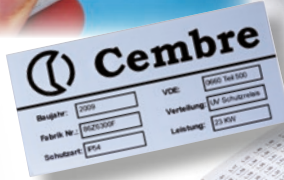

THERMAL TRANSFER SYSTEM
FOR REEL MEDIA PRINTING



ASK FOR THE CATALOGUES



Cembre

Crimpstar

ZETAmini

MAXIblock



nd

ZETApiù

spiralblock

oelma

MARKIN
Genius

ZETAblock

MAXIbrass



SICURclips

are registered trademarks of Cembre S.p.A.

The information contained in this catalogue is to aid the commercial selection of products.
It is not intended for use as an instruction manual.

Information concerning application and the correct operational use is provided by the specific manual delivered with the products.

This catalogue is the property of Cembre.
Any reproduction (in full or in part) is forbidden without
the prior written permission of Cembre.

Cembre reserve the right to modify the specifications
in this catalogue without prior notice.



Cembre S.p.A.
Via Serenissima, 9
25135 Brescia (Italia)
Telefono: +39 030 36921
Telefax: +39 030 3365766
E-mail: sales@cembre.com
www.cembre.it



Cembre Ltd.
Dunton Park
Kingsbury Road, Curdworth - Sutton Coldfield
West Midlands B76 9EB (UK)
Tel.: +44 01675 470440 - Fax: +44 01675 470220
E-mail: sales@cembre.co.uk
www.cembre.co.uk



Cembre S.a.r.l.
22 Avenue Ferdinand de Lesseps
91423 Morangis (France)
Tél.: +33 01 60 49 11 90 - Fax: +33 01 60 49 29 10
CS 92014 - 91423 Morangis Cédex
E-mail: info@cembre.fr
www.cembre.fr



Cembre España S.L.U.
Calle Verano 6 y 8
Polígono Industrial "Las Monjas"
28850 Torrejón de Ardoz - Madrid (España)
Teléfono: +34 91 4852580 - Fax: +34 91 4852581
E-mail: comercial@cembre.es
www.cembre.es



Cembre GmbH
Heidemannstraße 166
80939 München (Deutschland)
Telefon: +49 89 3580676
E-mail: sales@cembre.de
www.cembre.de



Cembre Inc.
Raritan Center Business Park
181 Fieldcrest Avenue
Edison, New Jersey 08837 (USA)
Tel.: +1 732 225-7415 - Fax: +1 732 225-7414
E-mail: Sales.US@cembre.com
www.cembreinc.com

IKUMA GmbH & Co. KG
Boschstraße 7
71384 Weinstadt
Telefon: +49 7151 20536 - 60
Telefax: +49 7151 20536 - 80
E-mail: info@ikuma.de
www.ikuma.de

Any other country, please contact Cembre S.p.A. - Italy

www.cembre.com



You Tube *This is Cembre*



Cod. 6260474